

HFD3-H

MINIATURE 3TH SIGNAL RELAY



File No.: E133481



File No.: R50535119

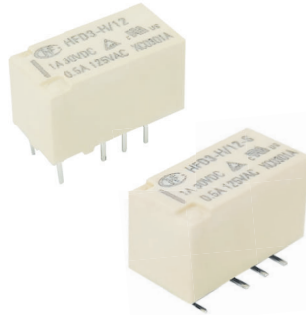

Features

- 3th signal relay
- Surge withstand voltage up to 2.5kV
- Low coil power at 50mW.
Coil (5V) operating current $\leq 10\text{mA}$
- Bifurcated contacts
- Meets IEC 62368-1
- SMT and THT types available
- Single side stable and latching type available
- Products compliant with IEC 60079 available
- Products compliant with IEC 60335-1 available

RoHS compliant

CONTACT DATA

Contact arrangement	2C
Contact resistance ¹⁾	100mΩ max. (at 10mA 30mVDC)
Contact material	Ag alloy+Au plated
Contact rating(Res. load)	1A 30VDC, 2A 30VDC, 0.5A 110VDC 0.5A 125VAC, 0.5A 277VAC
Max. switching voltage	277VAC/110VDC
Max. switching current	2A
Max. switching power	138.5VA/60W
Min. applicable load ²⁾	10mV 10μA
Mechanical endurance	5×10 ⁷ OPS
Electrical endurance	2×10 ⁵ OPS (Ag alloy+Au plated, 1A 30VDC, Resistive load, 70°C, 1s on 9s off)
	1×10 ⁵ OPS (Ag alloy+Au plated, 0.5A 110VDC, Resistive load, 70°C, 1s on 9s off)
	1×10 ⁵ OPS (Ag alloy+Au plated, 0.5A 125VAC, Resistive load, 70°C, 1s on 9s off)
	1×10 ⁵ OPS (Ag alloy+Au plated, 0.5A 277VAC, Resistive load, 70°C, 1s on 9s off)

- Notes:** 1) The data shown above are initial values.
 2) Min. applicable load is reference value. Please perform the confirmation test with the actual load before production since reference value may change according to switching frequencies, environmental conditions and expected contact resistance and reliability.
 3) The electrical endurance is from the tests of one set of open contacts or one sets of close contacts.

CHARACTERISTICS

Insulation resistance		1000MΩ (500VDC)
Dielectric strength	Between open contacts	750VAC 1min
	Between coil & contacts	2000VAC 1min
	Between contact sets	1500VAC 1min
Surge withstand voltage	Between open contacts (10X160μs)	1500V(FCC part 68)
	Between coil & contacts (2X10μs)	2500V(Telecordia)
Operate time (Set time)		5ms max.
Release time (Reset time)		5ms max.
Shock resistance	Functional	735m/s ²
	Destructive	980m/s ²
Vibration resistance	Functional	10Hz~55Hz 3.3mm DA
	Destructive	10Hz~55Hz 5.0mm DA
Humidity		5% to 85%RH
Ambient temperature		-40°C to 70°C
Termination		THT, SMT
Unit weight		Approx. 2g
Moisture sensitivity levels (Only for SMT type, JEDEC-STD-020)		MSL-3
Construction		Plastic sealed

Notes: 1) The data shown above are initial values.

SAFETY APPROVAL RATINGS

UL/CUL	Ag alloy+Au plated	1A 30VDC 70°C
		2A 30VDC 40°C
		0.5A 110VDC 70°C
		0.5A 125VAC 70°C
		0.5A 277VAC 70°C
TÜV	Ag alloy+Au plated	1A 30VDC 70°C
		2A 30VDC 40°C
		0.5A 110VDC 70°C
		0.5A 125VAC 70°C
		0.5A 277VAC 70°C

Notes: 1) Only typical loads are listed above. Other load specifications can be available upon request.

COIL

Coil power	Single side stable	See table "COIL DATA"
	1 coil latching	See table "COIL DATA"
	2 coil latching	See table "COIL DATA"
Temperature rise	$\leq 50\text{K}$ (1A Load, at 70°C)	



HONGFA RELAY

ISO9001, IATF16949, ISO14001, OHSAS18001, IECQ QC 080000 CERTIFIED

2026 Rev. 1.01

COIL DATA

23°C

Single side stable

Coil Code	Nominal Voltage VDC ¹⁾	Initial Pick-up Voltage VDC max.	Initial Drop-out Voltage VDC max.	Coil Resistance Ω	Nominal current mA	Nominal Power mW approx	Max. Voltage VDC ⁴⁾
HFD3-H/1.5	1.5	1.2	0.15	45×(1±10%)	33.3	50	3
HFD3-H/2.4	2.4	1.92	0.24	115×(1±10%)	20.8	50	4.8
HFD3-H/3	3	2.4	0.30	180×(1±10%)	16.7	50	6
HFD3-H/4.5	4.5	3.6	0.45	405×(1±10%)	11.1	50	9
HFD3-H/5	5	4.0	0.5	500×(1±10%)	10.0	50	10
HFD3-H/6	6	4.8	0.6	720×(1±10%)	8.3	50	12
HFD3-H/9	9	7.2	0.9	1620×(1±10%)	5.6	50	18
HFD3-H/12	12	9.6	1.2	2880×(1±10%)	4.2	50	24
HFD3-H/24	24	19.2	2.4	8229×(1±10%)	2.9	70	48

1 coil latching

Coil Code	Nominal Voltage VDC ¹⁾	Initial Set Voltage VDC max. ¹⁾	Initial Reset Voltage VDC max. ¹⁾	Coil Resistance ¹⁾ Ω	Nominal current mA	Nominal Power mW approx	Max. Voltage VDC ⁴⁾
HFD3-H/1.5-L1	1.5	1.2	1.2	45×(1±10%)	33.3	50	3
HFD3-H/2.4-L1	2.4	1.92	1.92	115×(1±10%)	20.8	50	4.8
HFD3-H/3-L1	3	2.4	2.4	180×(1±10%)	16.7	50	6
HFD3-H/4.5-L1	4.5	3.6	3.6	405×(1±10%)	11.1	50	9
HFD3-H/5-L1	5	4.0	4.0	500×(1±10%)	10.0	50	10
HFD3-H/6-L1	6	4.8	4.8	720×(1±10%)	8.3	50	12
HFD3-H/9-L1	9	7.2	7.2	1620×(1±10%)	5.6	50	18
HFD3-H/12-L1	12	9.6	9.6	2880×(1±10%)	4.2	50	24
HFD3-H/24-L1	24	19.2	19.2	8229×(1±10%)	2.9	70	48

2 coil latching

Coil Code	Nominal Voltage VDC ¹⁾	Initial Set Voltage VDC max. ¹⁾	Initial Reset Voltage VDC max. ¹⁾	Coil Resistance ¹⁾ Ω	Nominal current mA	Nominal Power mW approx	Max. Voltage VDC ⁴⁾
HFD3-H/1.5-L2	1.5	1.2	1.2	32×(1±10%)	46.7	70	3
HFD3-H/2.4-L2	2.4	1.92	1.92	82×(1±10%)	29.2	70	4.8
HFD3-H/3-L2	3	2.4	2.4	129×(1±10%)	23.3	70	6
HFD3-H/4.5-L2	4.5	3.6	3.6	289×(1±10%)	15.6	70	9
HFD3-H/5-L2	5	4.0	4.0	357×(1±10%)	14.0	70	10
HFD3-H/6-L2	6	4.8	4.8	514×(1±10%)	11.7	70	12
HFD3-H/9-L2	9	7.2	7.2	1157×(1±10%)	7.8	70	18
HFD3-H/12-L2	12	9.6	9.6	2057×(1±10%)	5.8	70	24
HFD3-H/24-L2	24	19.2	19.2	3840×(1±10%)	6.3	150	48

COIL DATA

23°C

Notes: 1) The data shown above are initial values.

2) To supply rated step voltage to coil is the foundation of relay proper operation. Please make sure the applied voltage to the coil reach at rated values.

Please refer to the typical diagram below for single side stable relay. The "V_coil" is the rated voltage.:

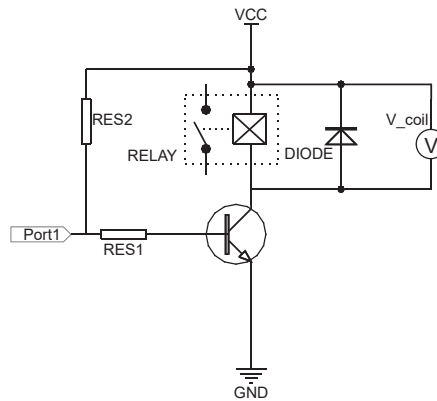

3) In case 5V of transistor drive circuit, it is recommended to use 4.5V type relay, and 3V to use 2.4V type relay.

4) For monostable relays, if you need to drop down voltage and hold mode after reliably operating, make sure that the effective value of holding voltage is not less than 60% of the rated voltage.

5) Maximum voltage refers to the maximum voltage which relay coil could endure in a short period of time.

6) When user's requirements can't be found in the above table, special order allowed.

7) During the relay pick-up or drop-out processes, there are stages of contact pressure change, contact vibration and unstable contact etc.

When the voltage applied to coil is gradually changed, it will lengthen the unstable stage and affect relay endurance. To reduce this influence, please apply step voltage (switching circuit) to relay coil.

ORDERING INFORMATION

Type	HFD3-H/	12	-L1	S	R	(XXX)
Coil voltage	1.5, 2.4, 3, 4.5, 5, 6, 9, 12, 24VDC					
Sort	L1: 1 coil latching L2: 2 coil latching Nil: Single side stable					
Terminal type	S: Standard SMT		S1: Short terminal SMT		Nil: THT ¹⁾	
Packing style	R: Tape and reel packing (Only for SMT type) ²⁾ Nil: Tube packing (Only for THT type)					
Special code ³⁾	XXX: Customer special requirement		Nil: Standard			
	825: For light load applications: testing, medical, communications, etc.					

Notes: 1) THT relays: Use wave or manual soldering. Confirm reflow soldering feasibility with us first.

2) R type (tape and reel) packing is moisture-proof which meets requirement of MSL-3. Please choose R type packing for SMT products.

For R type, the letter "R" will only be printed on packing tag but not on relay cover. Tube packing is normally not available for SMT products unless specially requested by customer. But please note that tube packing is not moisture-proof so please bake the products before use according to description of Notice 12 herewith. In addition, tube packaging will be adopted when the ordering quantity of R type is equal to or less than 100 pieces unless otherwise specified.

3) The customer special requirement express as special code after evaluating by Hongfa.

4) When coil sort, terminal type or packing style are needed, please add "-" after coil voltage is selected. For instance, HFD3-H/12-SR.

5) The standard tube length is 624mm, Any special requirement needed, please contact us for more details.

6) For products that should meet the explosion-proof requirements of "IEC 60079 series", please note [Ex] after the specification while placing orders. Not all products have explosion-proof certification, so please contact us if necessary, in order to select the suitable products.

7) Please make sure that there are no silicon-based substances (such as silicon rubber, silicone oil, silicon-based coating agents, silicon fillers, etc.) around the relay, because it will generate silicon-containing volatile gas, which may cause poor contact in case of silicon-containing volatile gas sticking on contact. Flux proofed and dust cover type relays are prohibited in environments with water vapor and harmful gases (P, Cl, H₂S, SO₂, NO₂). Plastic sealed relays shall be used with practical test verification.

OUTLINE DIMENSIONS, WIRING DIAGRAM AND PC BOARD LAYOUT

Unit: mm

Outline Dimensions
(THT type)

Single side stable & 1 coil latching

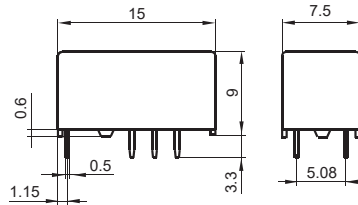

2 coils latching

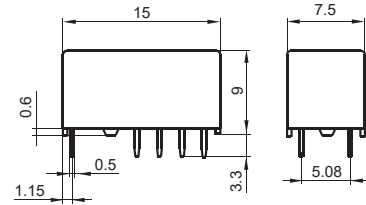

PCB Layout
(THT type)
(Bottom view)

Single side stable & 1 coil latching

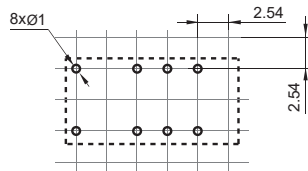

2 coils latching

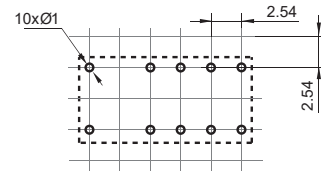

Outline Dimensions
(S type: Standard SMT)

Single side stable & 1 coil latching

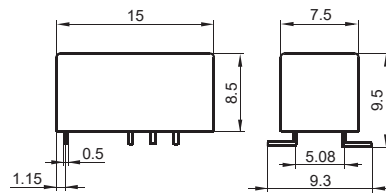

2 coils latching

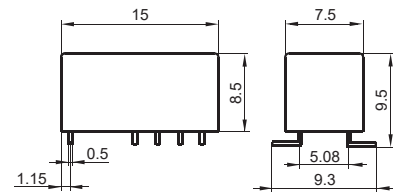

PCB Layout
(S type: Standard SMT)
(Bottom view)

Single side stable & 1 coil latching

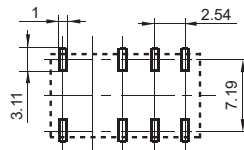

2 coils latching

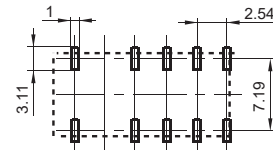

OUTLINE DIMENSIONS, WIRING DIAGRAM AND PC BOARD LAYOUT

Unit: mm

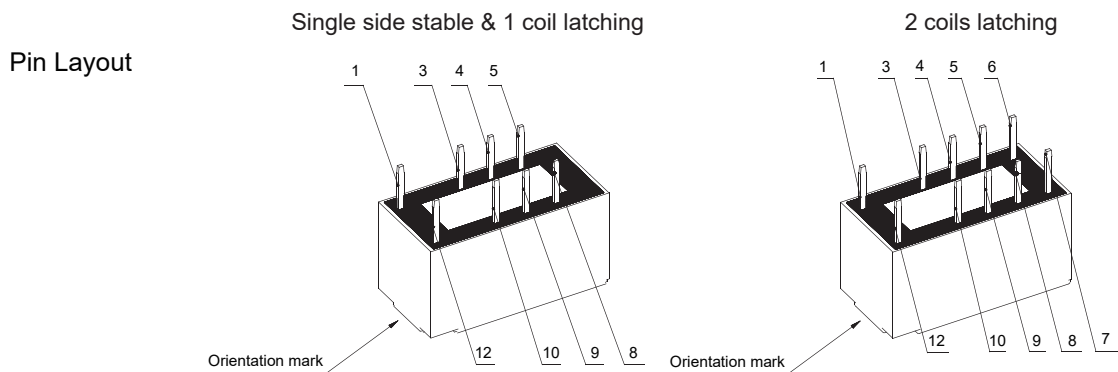
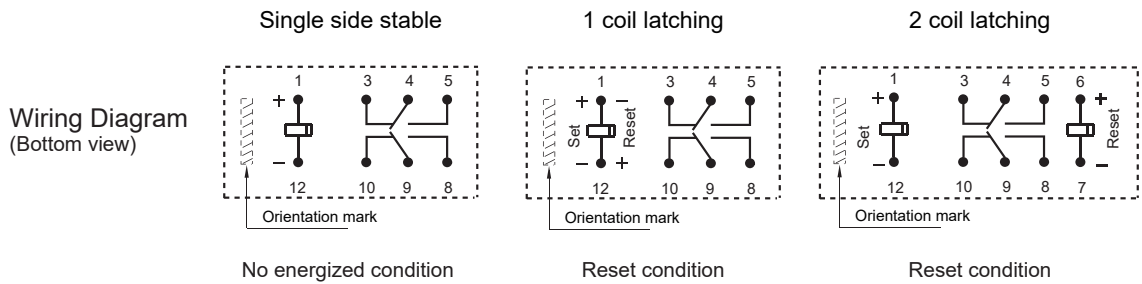
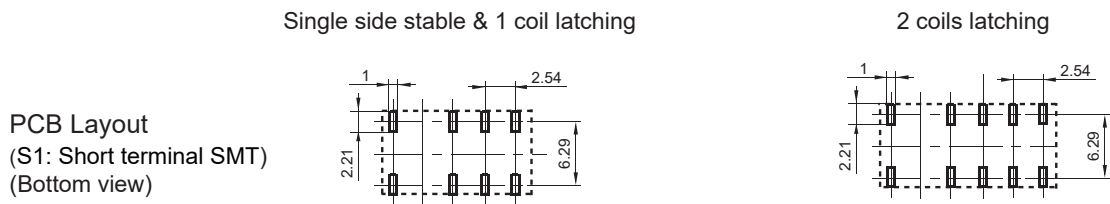
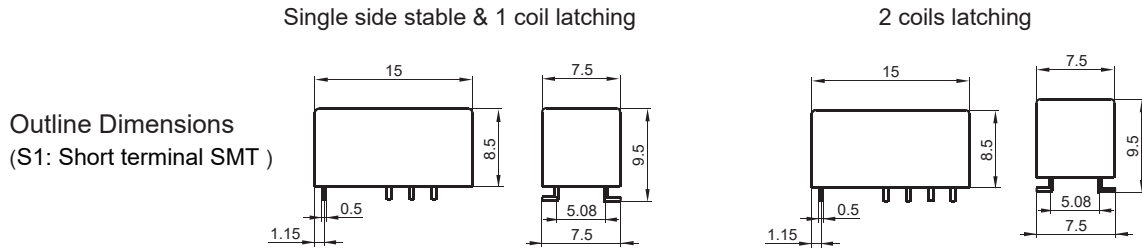

- Remark: 1) The pin dimension of the product outline drawing is the size before tinning (it will become larger after tinning), and the mounting hole size is the recommended design size of the PCB board hole. The specific PCB board hole design size can be mapped and adjusted according to the actual product.
- 2) In case of no tolerance shown in outline dimension: outline dimension $\leq 1\text{mm}$, tolerance should be $\pm 0.2\text{mm}$; outline dimension $> 1\text{mm}$ and $\leq 5\text{mm}$, tolerance should be $\pm 0.3\text{mm}$; outline dimension $> 5\text{mm}$, tolerance should be $\pm 0.4\text{mm}$.
- 3) The tolerance without indicating for PCB layout is always $\pm 0.1\text{mm}$.

Direction of Relay Insertion

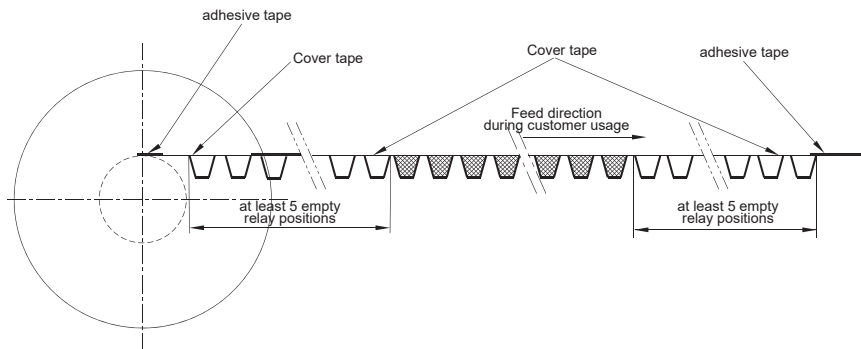
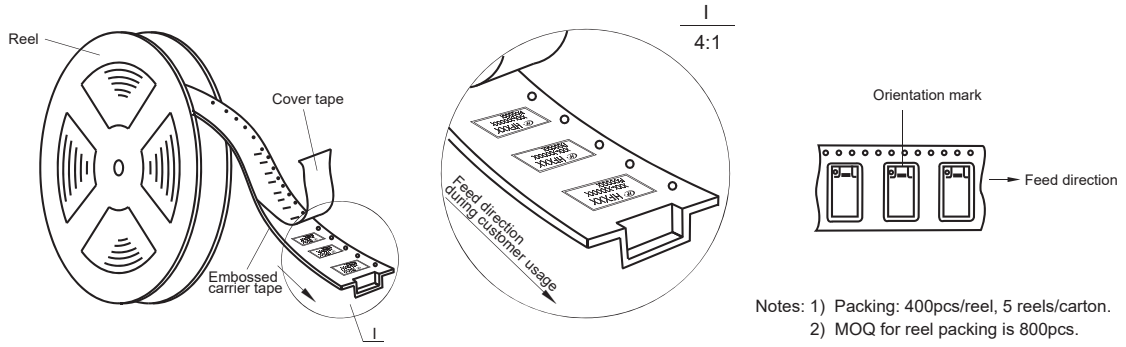

Reel Dimensions

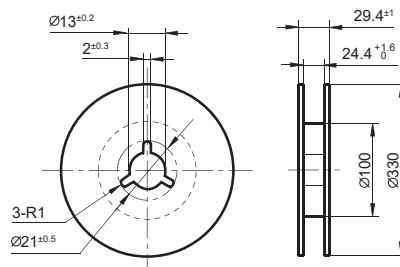

Tape Dimensions
(S type: Standard SMT)

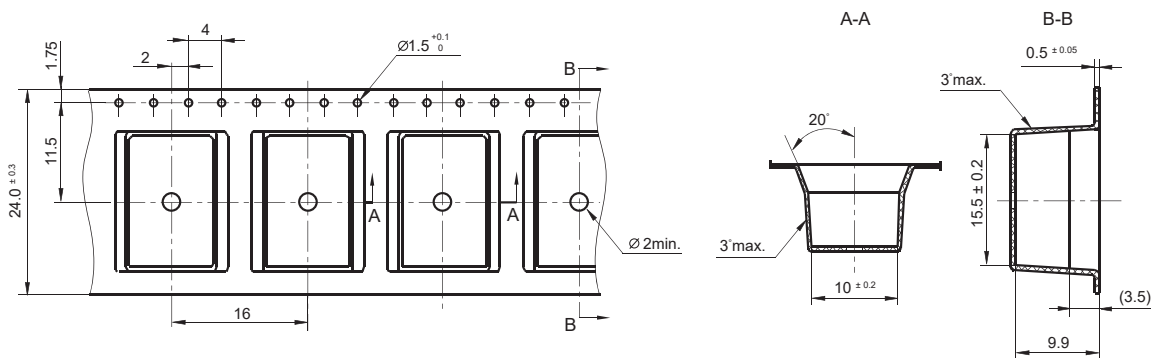

TAPE PACKING

Unit: mm

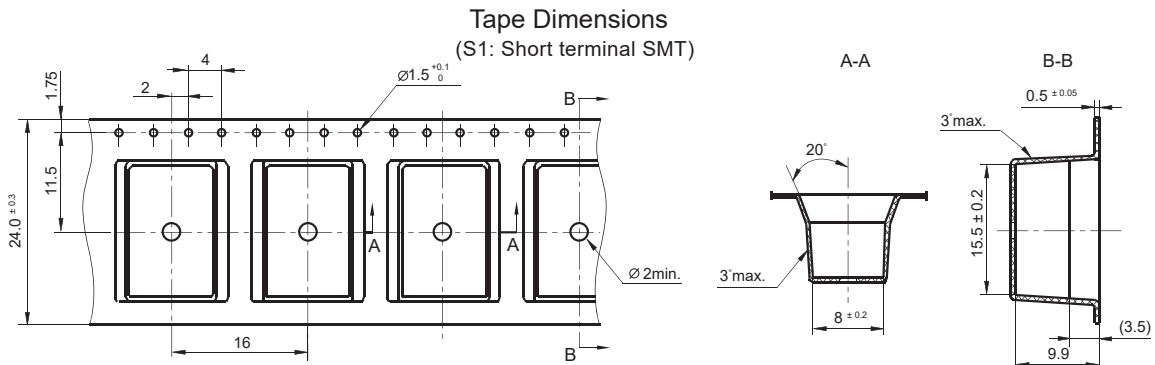

CHARACTERISTIC CURVES

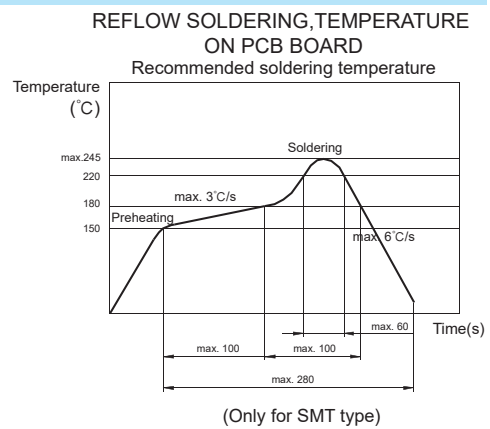
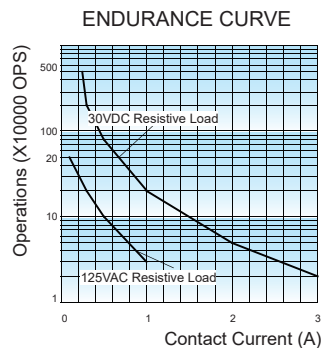
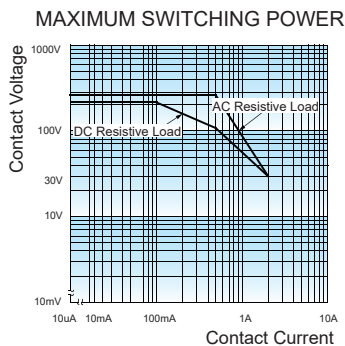

Test conditions:
Resistive load, 1s on 9s off.

Notice

- 1) This relay is highly sensitive polarized relay, if correct polarity is not applied to the coil terminals, the relay does not operate properly.
- 2) To avoid using relays under strong magnetic field which will change the parameters of relays such as pick-up voltage and drop-out voltage.
- 3) Relay is on the "reset" status when being released from stock, with the consideration of shock risen from transit and relay mounting, it should be changed to the "set" status when application (connecting to the power supply). Please reset the relay to "set" or "reset" status on request.
- 4) Energizing coil with rated voltage is basic for normal operation of a relay, please make sure the energized voltage to relay coil have reached the rated voltage. Regarding latching relay, in order to maintain the "set" or "reset" status, impulse width of the rated voltage applied to coil should be more than 5 times of "set" or "reset" time.
- 5) For a monosteady state relay, after the relay is reliably operated, if it needs to be kept under pressure, make sure that the effective value of the voltage is not less than 60% of the rated voltage;
- 6) The relay may be damaged because of falling or when shocking conditions exceed the requirement.
- 7) For 2 coil latching relay, do not energize voltage to "set" coil and "reset" coil simultaneously.
- 8) For SMT products, validation with real application should be done before your series production, if the reflow-soldering temperature curve is out of our recommendation. Generally, two-time reflow-soldering is not recommended for the relay. However, if two-time reflow-soldering is required, a 60-min. interval should be guaranteed and a validation should be done before production.
- 9) Please use wave soldering or manual soldering for straight-in relay. If you need reflow welding, please confirm the feasibility with us.
- 10) Contact is recommended for suitable condition and specifications if water cleaning or surface process is involved in assembling relays on PCB.
- 11) Regarding the plastic sealed relay, we should leave it cooling naturally until below 40°C after welding, then clean it and deal with coating, remarkably the temperature of solvents should also be controlled below 40°C. Please avoid cleaning the relay by ultrasonic, avoid using the solvents like gasoline, Freon, and so on, which would affect the configuration of relay or influence the environment.
- 12) Relays packaged in moisture barrier bags meet MSL-3 requirements. The relays should be stored at ambient conditions of ≤30°C and ≤60% RH after they are removed from their packaging, and should be used within 168 hours. If the relays cannot be used within 168 hours, please repack them or store them in a drying oven at 25°C ± 5°C, ≤10% RH. Otherwise, relays may be subjected to a soldering test to check their performance, or they may be used after keeping them in an oven for 72 hours at with 50°C ± 5°C, ≤30% RH.
- 13) When applied with continuous current, the heat from relay coil will age its isolation. Thus, please do not ground connected the coil to reduce electrical erosion if possible. And please provide protection circuit to avoid broken wire and losses.
- 14) Please make sure that there are no silicon-based substances (such as silicon rubber, silicone oil, silicon-based coating agents, silicon fillers, etc.) around the relay, because it will generate silicon-containing volatile gas, which may cause poor contact in case of silicon-containing volatile gas sticking on contact. Flux proofed and dust cover type relays are prohibited in environments with water vapor and harmful gases (P, Cl, H₂S, SO₂, NO₂). Plastic sealed relays shall be used with practical test verification.
- 15) About preferable condition of operation, storage and transportation, please refer to "Explanation to terminology and guidelines of relay."
- 16) During the relay pick-up or drop-out processes, there are stages of contact pressure change, contact vibration and unstable contact etc. When the voltage applied to coil is gradually changed, it will lengthen the unstable stage and affect relay endurance. To reduce this influence, please apply step voltage (switching circuit) to relay coil.

Disclaimer

The specification is for reference only. See to "Terminology and Guidelines" for more information. Specifications subject to change without notice. We could not evaluate all the performance and all the parameters for every possible application. Thus the user should be in a right position to choose the suitable product for their own application. If there is any query, please contact Hongfa for the technical service. However, it is the user's responsibility to determine which product should be used only.

© Xiamen Hongfa Electroacoustic Co., Ltd. All rights of Hongfa are reserved.