

# HFE29(864)

# HIGH POWER LATCHING RELAY

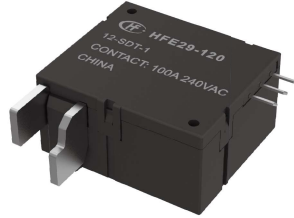

### Features

- 120A Latching relay
- Electrical endurance 10000ops
- According to IEC62055-31:UC3  
IEC62052-31:UC3
- Contact resistance  $\leq 0.35m\Omega$

RoHS compliant

### CONTACT DATA

|                                  |   |
|----------------------------------|---|
| Contact arrangement              | 1A(Dual contact), 1B(Dual contact)                    |
| Contact resistance <sup>1)</sup> | Typical value: <sup>2)</sup> $\leq 0.35m\Omega(100A)$ |
| Contact material                 | AgSnO <sub>2</sub>                                    |
| Contact rating                   | See "electrical endurance"                            |
| Max. switching voltage           | 276VAC  |
| Max. switching current           | 120A  |
| Max. switching power             | 33120W  |
| Mechanical endurance             | Meter: $1 \times 10^5$ ops                            |

Notes: 1) The data shown above are initial values.

2) Typical value: Sampling quantity for contact resistance shall not less than 20 pcs, take the average value from 5 continuous measurements for each sample.

### CHARACTERISTICS

|                             |                          |                     |
|-----------------------------|--------------------------|---------------------|
| Insulation resistance       | 1000M $\Omega$ (500VDC)  |                     |
| Dielectric strength         | Between coil and contact | 4000VAC 1min        |
|                             | Between open contacts    | 2000VAC 1min        |
|                             | Between open contacts    | 4000VAC 1min        |
| Creepage distance           | 8mm                      |                     |
| Set time (at nomi. volt.)   | $\leq 20ms$              |                     |
| Reset time (at nomi. volt.) | $\leq 20ms$              |                     |
| Shock resistance            | Functional               | 98m/s <sup>2</sup>  |
|                             | Destructive              | 980m/s <sup>2</sup> |
| Vibration resistance        | 10Hz ~ 55Hz 1.5mm DA     |                     |
| Humidity                    | 5% ~ 85% RH              |                     |
| Ambient temperature         | -40°C ~ 85°C             |                     |
| Termination                 | Coil termination         | PCB&QC              |
|                             | Load termination         | QC                  |
| Unit weight                 | Approx. 75g              |                     |
| Construction                | Dust protected           |                     |

Notes: The data shown above are initial values.

### COIL

|             |   |
|-------------|---|
| Rated power | Single coil latching: Approx. 3.0W<br>Double coils latching: Approx. 6.0W |
|-------------|---|

### COIL DATA

23°C

#### Single coil latching

| Nominal Voltage VDC | Set / Reset Voltage VDC <sup>1)2)</sup> | Pulse Duration (Recommended) ms | Coil Resistance x (1 $\pm$ 10%) $\Omega$ |
|---------------------|---|---------------------------------|--|
| 6                   | $\leq 4.8$                              | 50~100                          | 12                                       |
| 9                   | $\leq 7.2$                              | 50~100                          | 27                                       |
| 12                  | $\leq 9.6$                              | 50~100                          | 48                                       |
| 24                  | $\leq 19.2$                             | 50~100                          | 192                                      |
| 48                  | $\leq 38.4$                             | 50~100                          | 768                                      |

#### Double coils latching

| Nominal Voltage VDC | Set / Reset Voltage VDC <sup>1)2)</sup> | Pulse Duration (Recommended) ms | Coil Resistance x (1 $\pm$ 10%) $\Omega$ |
|---------------------|---|---------------------------------|--|
| 6                   | $\leq 4.8$                              | 50~100                          | 6+6                                      |
| 9                   | $\leq 7.2$                              | 50~100                          | 13.5+13.5                                |
| 12                  | $\leq 9.6$                              | 50~100                          | 24+24                                    |
| 24                  | $\leq 19.2$                             | 50~100                          | 96+96                                    |
| 48                  | $\leq 38.4$                             | 50~100                          | 384+384                                  |

Notes: 1) The data shown above are initial values.

2) The above values are used as incoming inspection standards, and the recommended driving voltage is 1~1.5 times of the rated voltage.

### ELECTRICAL ENDURANCE

| UC Class | Voltage (Vc) | Current (Ic) | Power Factor    | Close Open time (s) | Electrical endurance (ops) |
|----------|--------------|--------------|-----------------|---------------------|----------------------------|
| UC3      | 276VAC       | 100A         | COS $\phi$ =1   | 10:20               | 5000                       |
|          |              |              | COS $\phi$ =0.5 |                     | 5000                       |
|          |              |              |                 |                     | Total: 10000               |

Notes: 1) Electrical endurance meet IEC62055-31/IEC62052-31 test requirement, do the inductive load test after the resistive load test.

2) Only some typical ratings of UC are listed above, if more special ratings required, please contact us.



HONGFA RELAY

ISO9001、IATF16949、ISO14001、ISO45001、IECQ QC 080000、ISO/EC 27001

2025 Rev.1.00

## ORDERING INFORMATION

|                                   |  |  |  |  |  |  |  |
|-----------------------------------|--|--|--|--|--|--|--|
| Type                              | HFE29 -120 /12 -SD T -2 -R (864)   |  |  |  |  |  |  |
| Contact rating                    | 120: 120A  |  |  |  |  |  |  |
| Coil voltage                      | 6, 9, 12, 24, 48VDC  |  |  |  |  |  |  |
| Contact arrangement <sup>1)</sup> | SD: 1 Form B(Dual contact)<br>SH: 1 Form A(Dual contact)   |  |  |  |  |  |  |
| Contact material                  | T:AgSnO <sub>2</sub>   |  |  |  |  |  |  |
| Coil type                         | 1: Single coil latching    2: Double coils latching  |  |  |  |  |  |  |
| Polarity                          | R: Reverse polarity    Nil: Standard polarity  |  |  |  |  |  |  |
| Special code <sup>2)3)</sup>      | XXX: Customer special requirement    (864):refers to the fixed identification<br>(922):stands for the relay with microswitch |  |  |  |  |  |  |

Notes:1)SH means that relay is on the "reset" status when delivery; SD means that relay is on the "set" status when delivery. If no special required by customer, we will keep the relay on the "set" status when delivery.

2) The customer special requirement express as special code after evaluating by Hongfa. e.g. (922) stands for the relay with microswitch.

## OUTLINE DIMENSIONS AND WIRING DIAGRAM

Unit: mm

### Outline Dimensions

HFE29-120(864)

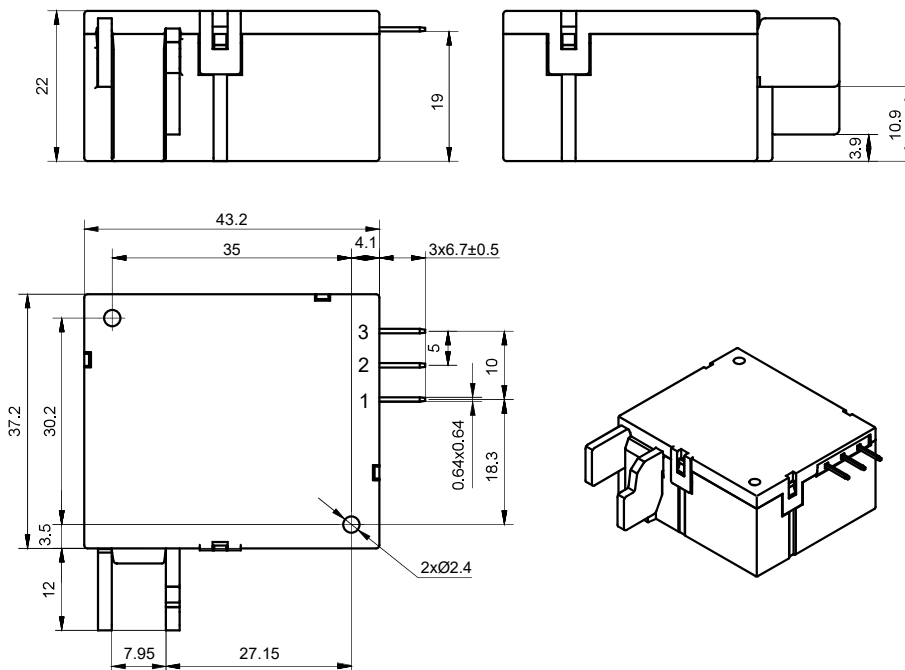

Remark: 1) The dimension of the load terminals as well as the sampling resistance can be made per customer request.

2) In case of no tolerance shown in outline dimension: outline dimension ≤1mm, tolerance should be ±0.2mm; outline dimension > 1mm and ≤5mm, tolerance should be ±0.3mm; outline dimension > 5mm, tolerance should be ±0.4mm.

**Outline Dimensions**

HFE29-120(864)(922)

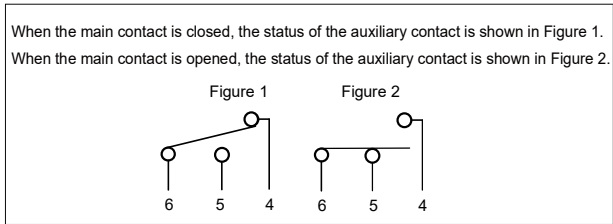
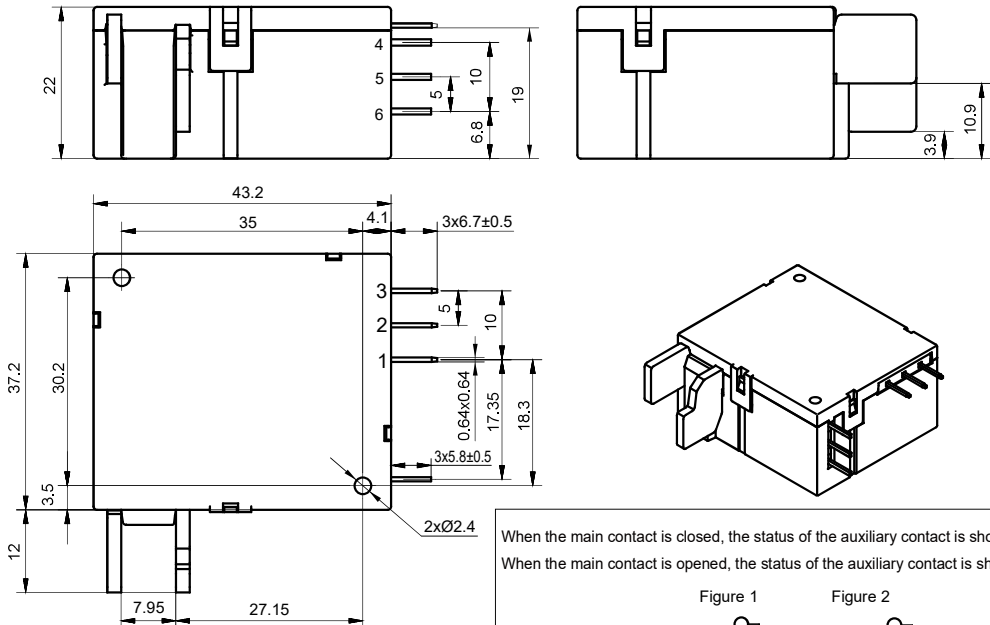

**Wiring Diagram**

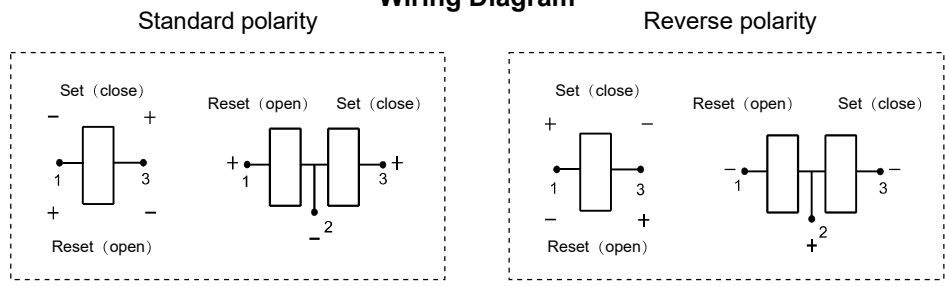

**CAUTIONS**

1. Relay is on the "reset" or "set" status when being released from stock, with the consideration of shock risen from transit and relay mounting, relay would be changed to "set" or "reset" status, therefore, when application (connecting the power supply), please reset the relay to "set" or "reset" status on request.
2. Do not energize voltage to "set" coil and "reset" coil simultaneously. And also long energized time (more than 1 min) should be avoided.
3. Normally the load terminals are not suitable for reflow solder, wave solder or tin solder, we suggest use spot welding. Load terminals shall be prevented from assembly stress, or freely move.
4. Relays used for metering measuring applications are usually made with dust proof structure, while most relays could be made specially per customer's specific requirements. No longer than 6 months' storage time is recommended for this kind of relay, and please pay attention to the storage environment. To ensure contact reliability, we will keep contact status be closed when delivery if no special required by customer.

**Disclaimer**

The specification is for reference only. Specifications subject to change without notice.  
 We could not evaluate all the performance and all the parameters for every possible application. Thus the user should be in a right position to choose the suitable product for their own application. If there is any query, please contact Hongfa for the technical service. However, it is the user's responsibility to determine which product should be used only.