

HFE37

HIGH POWER LATCHING RELAY

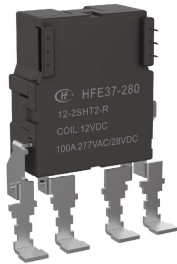

Features

- 100A Latching relay
- Electrical endurance 10000ops
- According to IEC62055-31:UC1, UC2, UC3
- Contact resistance $\leq 0.35m\Omega$

RoHS compliant

CONTACT DATA

Contact arrangement	2A(Dual contact),2B(Dual contact)
Contact resistance ¹⁾	Typical value: ²⁾ $\leq 0.35m\Omega(100A)$
Contact material	AgSnO ₂
Contact rating	See "electrical endurance"
Max. switching voltage	276VAC
Max. switching current	100A
Max. switching power	27600VA
Mechanical endurance	1x10 ⁵ ops

Notes:1) The data shown above are initial values.

2) Typical value: Sampling quantity for contact resistance shall not less than 20 pcs, take the average value from 5 continuous measurements for each sample.

CHARACTERISTICS

Insulation resistance		1000M Ω (500VDC)
Dielectric strength	Between coil and contact	4000VAC 1min
	Between open contacts	2500VAC 1min
Creepage distance		9.6mm
Set time (at nomi. volt.)		20ms max.
Reset time (at nomi. volt.)		20ms max.
Shock resistance	Functional	294m/s ²
	Destructive	980m/s ²
Vibration resistance		10Hz to 55Hz 1.5mm DA
Humidity		5% to 85% RH
Ambient temperature		-40°C to 85°C
Termination	Coil ermination	PCB&QC
	Load termination	QC
Unit weight		Approx. 160g
Construction		Dust protected

Notes: The data shown above are initial values.

COIL

Rated power	Single coil latching: Approx. 4W
	Double coils latching: Approx. 8W

COIL DATA

at 23°C

Single coil latching

Nominal Voltage VDC	Set / Reset Voltage VDC ¹⁾²⁾ max.	Pulse Duration (Recommended) ms	Coil Resistance x (1 \pm 10%) Ω
6	≤ 4.8	50~100	9
9	≤ 7.2	50~100	20,25
12	≤ 9.6	50~100	36
24	≤ 19.2	50~100	144
48	≤ 38.4	50~100	576

Double coils latching

Nominal Voltage VDC	Set / Reset Voltage VDC ¹⁾²⁾ max.	Pulse Duration (Recommended) ms	Coil Resistance x (1 \pm 10%) Ω
6	≤ 4.8	50~100	4.5+4.5
9	≤ 7.2	50~100	10.1+10.1
12	≤ 9.6	50~100	18+18
24	≤ 19.2	50~100	72+72
48	≤ 38.4	50~100	288+288

Notes:1) The data shown above are initial values.

2) The above values are used as incoming inspection standards, and the recommended driving voltage is 1~1.5 times of the rated voltage.

ELECTRICAL ENDURANCE

UC Class	Voltage (Uc)	Current (Ic)	Power Factor	Close Open time (s)	Electrical endurance (ops)
415 (UC1)	230VAC	80A	COS ϕ =1	10:20	3000
		10A	COS ϕ =0.4		3000
416 (UC2)		80A	COS ϕ =1		5000
			COS ϕ =0.5		5000
417 (UC3)		100A	COS ϕ =1		5000
			COS ϕ =0.5		5000
					Total: 6000
					Total: 10000
					Total: 10000

Notes: 1) Electrical endurance meet IEC62052-31 test requirement, do the inductive load test after the resistive load test.

2) Only some typical ratings of UC are listed above, if more special ratings required, please contact us.

ORDERING INFORMATION

Type	HFE37 - 280 /12 -2SD T 2 -R (XXX)						
Sampling resistance	280: 280 $\mu\Omega$ Nil: Without sampling resistance						
Coil voltage	6, 9, 12, 24, 48VDC						
Contact arrangement ¹⁾	2SD: 2 Form B (Dual contact) 2SH: 2 Form A (Dual contact)						
Contact material	T: AgSnO ₂						
Coil type	1: Single coil latching			2: Double coils latching			
Polarity	R: Reverse polarity			Nil: Standard polarity			
Special code ²⁾³⁾	XXX: Customer special requirement						

Notes: 1) 2SH means that relay is on the "reset" status when delivery; 2SD means that relay is on the "set" status when delivery. If no special required by customer, we will keep the relay on the "set" status when delivery.

2) Please make clear your technical requirements, and choose from the following 3 UC ratings:

UC1: meet the UC1 requirements on IEC62055-31: Carrying test 1800A peak current for 10ms;

UC2: meet the UC2 requirements on IEC62055-31: Making test:2.5kA/10ms, carrying test 4.5kA/10ms;

UC3: meet the UC3 requirements on IEC62055-31: Making test:3kA/10ms, carrying test 6kA/10ms.

3) The customer special requirement express as special code after evaluating by Hongfa, e.g. (415) stands for UC1; e.g. (416) stands for UC2; e.g. (417) stands for UC3.

OUTLINE DIMENSIONS AND WIRING DIAGRAM

Unit: mm

Outline Dimensions

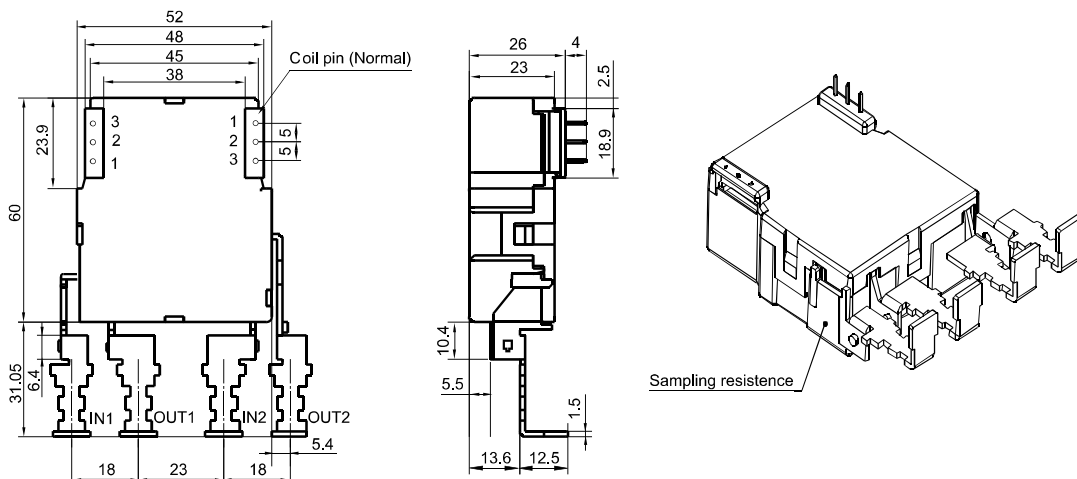

Remark: In case of no tolerance shown in outline dimension: outline dimension ≤ 1 mm, tolerance should be ± 0.2 mm; outline dimension > 1 mm and ≤ 5 mm, tolerance should be ± 0.3 mm; outline dimension > 5 mm, tolerance should be ± 0.4 mm.

OUTLINE DIMENSIONS AND WIRING DIAGRAM

Wiring Diagram

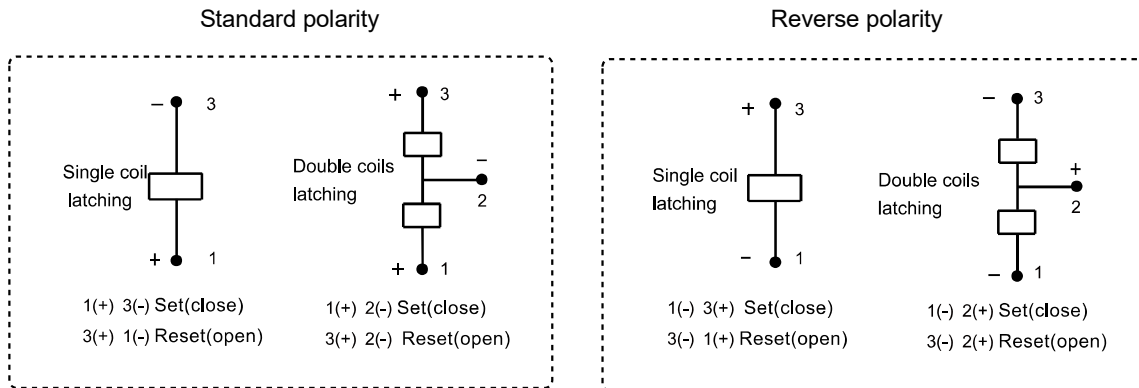

CAUTIONS

1. Relay is on the "reset" or "set" status when being released from stock, with the consideration of shock risen from transit and relay mounting, relay would be changed to "set" or "reset" status, therefore, when application (connecting the power supply), please reset the relay to "set" or "reset" status on request.
2. Do not energize voltage to "set" coil and "reset" coil simultaneously. And also long energized time (more than 1 min) should be avoided.
3. Normally the load terminals are not suitable for reflow solder, wave solder or tin solder, we suggest use spot welding. Load terminals shall be prevented from assembly stress, or freely move.
4. Relays used for metering measuring applications are usually made with dust proof structure, while most relays could be made specially per customer's specific requirements. No longer than 6 months' storage time is recommended for this kind of relay, and please pay attention to the storage environment. To ensure contact reliability, we will keep contact status be closed when delivery if no special required by customer.

Disclaimer

The specification is for reference only. Specifications subject to change without notice. We could not evaluate all the performance and all the parameters for every possible application. Thus the user should be in a right position to choose the suitable product for their own application. If there is any query, please contact Hongfa for the technical service. However, it is the user's responsibility to determine which product should be used only.

© Xiamen Hongfa Electroacoustic Co., Ltd. All rights of Hongfa are reserved.