

HFE68 SUBMINIATURE INTERMEDIATE POWER RELAY

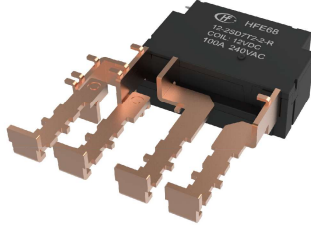

Features

- 120A Latching relay
- Electrical endurance 10000ops
- Terminal configuration LNNL
- According to IEC62055-31:UC2、UC3
- Contact resistance $\leq 0.5m\Omega$

RoHS compliant

CONTACT DATA

Contact arrangement	2A,2B
Contact resistance ¹⁾	Typical value: ²⁾ $\leq 0.5m\Omega(100A)$
Contact material	AgSnO ₂
Contact rating	See "electrical endurance"
Max. switching voltage	276VAC
Max. switching current	120A
Max. switching power	33120W
Mechanical endurance	Meter: 1×10^5 ops

Notes: 1) The data shown above are initial values.

2) Typical value: Sampling quantity for contact resistance shall not less than 20 pcs, take the average value from 5 continuous measurements for each sample.

CHARACTERISTICS

Insulation resistance	1000M Ω (500VDC)	
Dielectric strength	Between coil and contact	4000VAC 1min
	Between open contacts	2000VAC 1min
Creepage distance	9.5mm	
Set time (at nomi. volt.)	≤ 30 ms	
Reset time (at nomi. volt.)	≤ 30 ms	
Shock resistance	Functional	98m/s ²
	Destructive	980m/s ²
Vibration resistance	10Hz ~ 55Hz 1.5mm DA	
Humidity	5% ~ 85% RH	
Ambient temperature	-40°C ~ 85°C	
Termination	Coil termination	PCB&QC
	Load termination	QC
Unit weight	Approx. 169g	
Construction	Dust protected	

Notes: The data shown above are initial values.

COIL

Rated power	Single coil latching: Approx. 5W Double coils latching: Approx. 10W
-------------	--

COIL DATA

23°C

Single coil latching

Nominal Voltage VDC	Set / Reset Voltage ¹⁾²⁾ VDC	Pulse Duration (Recommended) ms	Coil Resistance x (1 \pm 10%) Ω
6	≤ 4.8	50~100	7.6
9	≤ 7.2	50~100	16.2
12	≤ 9.6	50~100	28.8
24	≤ 19.2	50~100	115.2
48	≤ 38.4	50~100	460.8

Double coils latching

Nominal Voltage VDC	Set / Reset Voltage ¹⁾²⁾ VDC	Pulse Duration (Recommended) ms	Coil Resistance x (1 \pm 10%) Ω
6	≤ 4.8	50~100	3.8+3.8
9	≤ 7.2	50~100	8.1+8.1
12	≤ 9.6	50~100	14.4+14.4
24	≤ 19.2	50~100	57.6+57.6
48	≤ 38.4	50~100	230.4+230.4

Notes: 1) The data shown above are initial values.

2) The above values are used as incoming inspection standards, and the recommended driving voltage is 1~1.5 times of the rated voltage.

ELECTRICAL ENDURANCE

UC Class	Voltage (Uc)	Current (Ic)	Power Factor	Close Open time (s)	Electrical endurance(ops)
UC2	240VAC	100A	COS ϕ =1	10:20	5000
			COS ϕ =0.5		5000
UC3	276VAC	100A	COS ϕ =1	10:20	5000
			COS ϕ =0.5		5000

Notes: 1) Electrical endurance meet IEC62055-31 test requirement, do the inductive load test after the resistive load test.

2) Coil driven by rated voltage.



HONGFA RELAY

ISO9001、IATF16949、ISO14001、ISO45001、IECQ QC 080000、ISO/EC 27001

2025 Rev.1.00

ORDERING INFORMATION

Type	HFE68 /12 -2SH 7 T 2 -1 -R (XXX)
Coil voltage	6,9,12,24,48VDC
Contact arrangement ¹⁾	2SH:2 Form A 2SD:2 FormB
Load terminal type	7:With customized connections
Contact material	T: AgSnO ₂
Coil angle form	2:No bowleg 4:Bowleg (See outline dimensions)
Coil type	1: Single coil latching 2: Double coils latching
Polarity	R: Reverse polarity Nil: Standard polarity
Special code	XXX: Customer special requirement

Notes:1) 2SH means that relay is on the "reset" status when delivery; 2SD means that relay is on the "set" status when delivery. If no special required by customer, we will keep the relay on the "set" status when delivery.

2) Please make clear your technical requirements, and choose from the following 3 UC ratings:

UC2: meet the UC2 requirements on IEC62055-31: Making test:2.5kA/10ms; carrying test 4.5kA/10ms;

UC3: meet the UC3 requirements on IEC62055-31: Making test:3kA/10ms; carrying test 6kA/10ms.

3) The customer special requirement express as special code after evaluating by Hongfa. e.g.(416) stands for UC2,(417) stands for UC3.

OUTLINE DIMENSIONS, WIRING DIAGRAM AND PCB LAYOUT

Unit: mm

Outline Dimensions

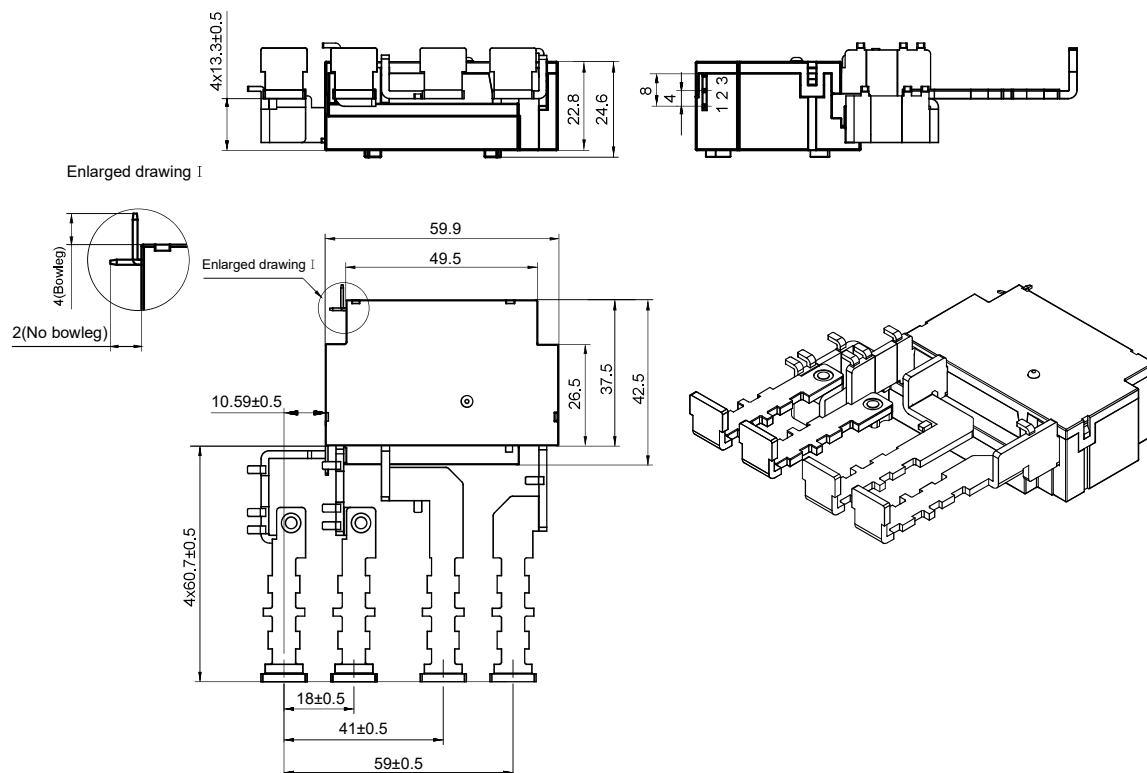

Note: 1) load terminal dimensions and sampling resistance can be customized made per customer request

2) In case of no tolerance shown in outline dimension: outline dimension ≤1mm, tolerance should be ±0.2mm; outline dimension >1mm and ≤5mm, tolerance should be ±0.3mm; outline dimension >5mm, tolerance should be ±0.4mm.

Wiring Diagram

Standard polarity

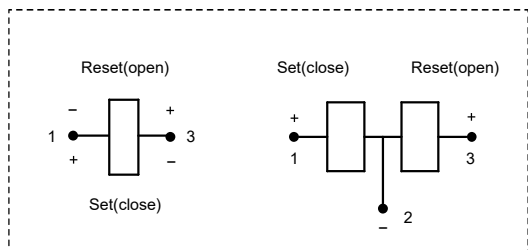

Reverse polarity

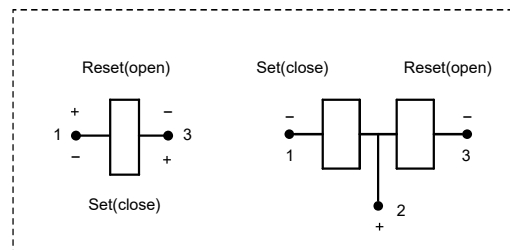

CAUTIONS

1. Relay is on the "reset" or "set" status when being released from stock, with the consideration of shock risen from transit and relay mounting, relay would be changed to "set" or "reset" status, therefore, when application (connecting the power supply), please reset the relay to "set" or "reset" status on request.
2. Do not energize voltage to "set" coil and "reset" coil simultaneously. And also long energized time (more than 1 min) should be avoided.
3. Normally the load terminals are not suitable for reflow solder, wave solder or tin solder, we suggest use spot welding. Load terminals shall be prevented from assembly stress, or freely move.
4. Relays used for metering measuring applications are usually made with dust proof structure, while most relays could be made specially per customer's specific requirements. No longer than 6 months' storage time is recommended for this kind of relay, and please pay attention to the storage environment. To ensure contact reliability, we will keep contact status be closed when delivery if no special required by customer.

Disclaimer

The specification is for reference only. Specifications subject to change without notice. We could not evaluate all the performance and all the parameters for every possible application. Thus the user should be in a right position to choose the suitable product for their own application. If there is any query, please contact Hongfa for the technical service. However, it is the user's responsibility to determine which product should be used only.