

# HFE60P

# SUBMINIATURE INTERMEDIATE POWER RELAY



File No.: E134517



File No.: B0532860048



File No.: CQC21002287482

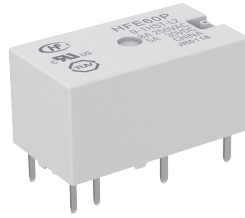

## Features

- Low height, only 10.5mm
- Low coil power
- High switching capacity  
1A: 8A 250VAC  
2A, 1A+1B: 5A 250VAC
- 3kV dielectric strength (between coil and contacts)

**RoHS compliant**

## CONTACT DATA

Contact arrangement	1A	2A, 1A+1B
Contact 1) resistance	Non gold plated: 30mΩ (at 1A 6VDC) Gold plated: 20mΩ (at 0.1A 6VDC)	
Contact material	AgSnO <sub>2</sub>	
Contact rating	8A 250VAC(COSφ=1.0) 5A 250VAC(COSφ=0.4) 0.3A 240VDC(τ=0ms) 0.15A 240VDC(τ=40ms) 5A 30VDC(τ=0ms)	5A 250VAC(COSφ=1.0) 3A 250VAC(COSφ=0.4) 0.3A 240VDC(τ=0ms) 0.15A 240VDC(τ=40ms) 5A 30VDC(τ=0ms)
Max. switching voltage	380VAC / 240VDC	
Max. switching current	8A	5A
Max. switching power	2000VA / 150W	1250VA / 150W
Mechanical endurance	1 x 10 <sup>7</sup> OPS	
Electrical endurance	1 x 10 <sup>4</sup> OPS(at 40°C, 1.5s on 1.5s off)	

Notes: 1) The data shown above are initial values.

## CHARACTERISTICS

Insulation resistance	1000MΩ (at 500VDC)	
Dielectric strength	Between coil & contacts	3000VAC 1min
	Between open contacts	1000VAC 1min
	Between contact sets	2000VAC 1min
Set time (monostable)	10ms max.	
Reset time (monostable)	5ms max.	
Set time (latching)	10ms max.	
Reset time (latching)	10ms max.	
Shock resistance	Functional	196m/s <sup>2</sup>
	Destructive	980m/s <sup>2</sup>
Vibration resistance	Functional	10Hz to 55Hz 2.0mm DA
	Destructive	10Hz to 55Hz 3.5mm DA
Humidity	5% to 85% RH	
Ambient temperature	-40°C to 85°C	
Termination	coil termination	PCB
	load termination	PCB
Unit weight	Approx. 4.5g	
Construction	Plastic sealed	

Notes: The data shown above are initial values.

## COIL

Rated power	Monostable: Approx. 300mW
	Single coil latching: Approx. 150mW
	Double coils latching: Approx. 300mW

## COIL DATA

at 23°C

### Monostable

Nominal Voltage VDC	Set Voltage 1) VDC 2)	Reset Voltage 1) VDC 2)	Max. Allowable Voltage VDC	Coil Resistance (1±10%)
3	1.35~2.25	0.3~1.2	3.9	30
5	2.5~3.5	0.5~2	6.5	83
6	3~4.2	0.6~2.4	7.8	120
9	4.5~6.3	0.9~3.6	11.7	270
12	6~8.4	1.2~4.8	15.6	480
24	12~16.8	2.4~9.6	31.2	1920

### Single coil latching

Nominal Voltage VDC	Set Voltage 1) VDC 2)	Reset Voltage 1) VDC 2)	Max. Allowable Voltage VDC	Coil Resistance (1±10%)
3	≤2.4	≤2.4	3.9	60
5	≤4	≤4	6.5	167
6	≤4.8	≤4.8	7.8	240
9	≤7.2	≤7.2	11.7	540
12	≤9.6	≤9.6	15.6	960
18	≤14.4	≤14.4	23.4	2160
24	≤19.2	≤19.2	31.2	3840

Notes: 1) The data shown above are initial values.

2) Above driving voltage only apply to check relay normal function without load. When normal use with load, use(1~1.5)U<sub>e</sub> for latching relay set/reset voltage, use(1~1.3)U<sub>e</sub> for set voltage and 0V for reset voltage for monostable relay.



HONGFA RELAY

ISO9001、IATF16949、ISO14001、ISO45001、IECQ QC 080000、ISO/EC 27001

2025 Rev.1.00

## COIL DATA

at 23°C

### Double coils latching

Nominal Voltage VDC	Set Voltage VDC 1) 2)	Reset Voltage VDC 1) 2)	Max. Allowable Voltage VDC	Coil Resistance (1±10%)
3	≤2.4	≤2.4	3.9	30+30
5	≤4	≤4	6.5	83.3+83.3
6	≤4.8	≤4.8	7.8	120+120
9	≤7.2	≤7.2	11.7	270+270
12	≤9.6	≤9.6	15.6	480+480
18	≤14.4	≤14.4	23.4	1080+1080
24	≤19.2	≤19.2	31.2	1920+1920

Notes: 1) The data shown above are initial values.

2) Above driving voltage only apply to check relay normal function without load. When normal use with load, use(1~1.5)Ue for latching relay set/reset voltage, use(1~1.3)Ue for set voltage and 0V for reset voltage for monostable relay.

## SAFETY APPROVAL RATINGS

<b>UL/CUL</b>	1 Form A: 8A 250VAC 5A 30VDC B300 R150 1/6HP 125VAC/250VAC	2 Form A / 1 Form A+1 Form B: 5A 250VAC 5A 30VDC B300 R150 1/6HP 125VAC/250VAC(For 1A1B) 1/10HP 125VAC/250VAC(For 2A)
<b>TÜV</b>	1 Form A: 8A 250VAC 5A 250VAC (COSØ=0.4) 5A 30VDC	2 Form A / 1 Form A+1 Form B: 5A 250VAC 3A 250VAC (COSØ=0.4) 5A 30VDC

Notes: 1) All values unspecified are at room temperature.

2) Only typical loads are listed above. Other load specifications can be available upon request.

## ORDERING INFORMATION

<b>Type</b>	<b>HFE60P/</b> <b>12</b> <b>-1HD</b> <b>S</b> <b>T</b> <b>G</b> <b>-L2</b> <b>-R</b> <b>(XXX)</b>
<b>Coil voltage</b>	3, 5, 6, 9, 12, 18, 24VDC
<b>Contact arrangement</b>	<b>1H:</b> 1 Form A <b>2H:</b> 2 Form A <b>1HD:</b> 1 Form A +1 Form B
<b>Construction</b>	<b>S:</b> Plastic sealed
<b>Contact material</b>	<b>T:</b> AgSnO <sub>2</sub>
<b>Contact plating</b>	<b>G:</b> Gold plated <b>Nil:</b> Non gold plated
<b>Coil type</b>	<b>L1:</b> Single coil latching <b>L2:</b> Double coils latching <b>Nil:</b> Monostable
<b>Polarity</b>	<b>R:</b> Reverse polarity <b>Nil:</b> Standard polarity
<b>Special code<sup>1)</sup></b>	<b>XXX:</b> Customer special requirement

Notes: 1) For clean environment (free from contamination, such as H<sub>2</sub>S, SO<sub>2</sub>, NO<sub>2</sub>, dust, etc.), flux proofed type is recommended. For contaminated environment, plastic sealed type is recommended and shall be confirmed in actual application.

2) If water cleaning or surface treatment is required after assembling relay on print circuit board, please contact us to confirm the suitable soldering conditions and specifications.

3) The customer special requirement express as special code after evaluating by Hongfa.

Outline Dimensions

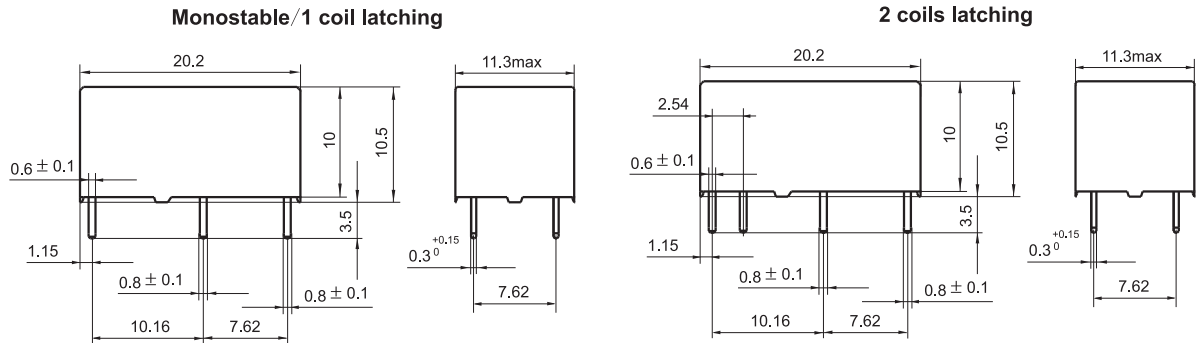

PCB Layout  
(Bottom view)

Monostable/1 coil latching

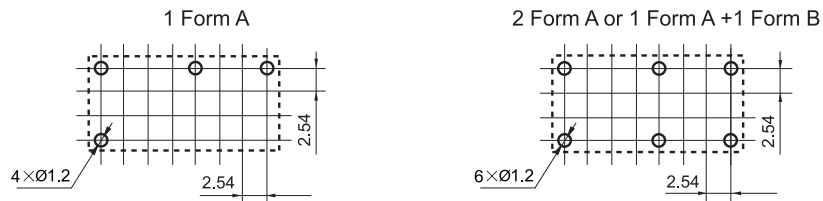

2 coils latching

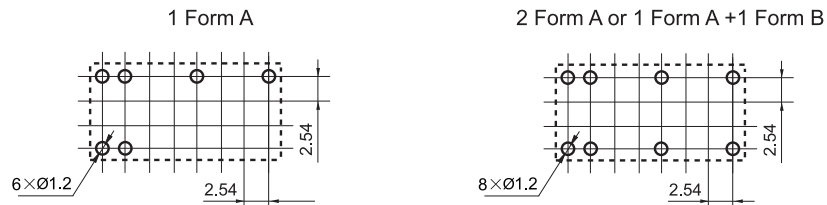

- Remark: 1) In case of no tolerance shown in outline dimension: outline dimension  $\leq 1\text{mm}$ , tolerance should be  $\pm 0.2\text{mm}$ ; outline dimension  $> 1\text{mm}$  and  $\leq 5\text{mm}$ , tolerance should be  $\pm 0.3\text{mm}$ ; outline dimension  $> 5\text{mm}$ , tolerance should be  $\pm 0.4\text{mm}$ .  
 2) The tolerance without indicating for PCB layout is always  $\pm 0.1\text{mm}$ .  
 3) The width of the gridding is 2.54mm.

Wiring Diagram  
(Bottom view)

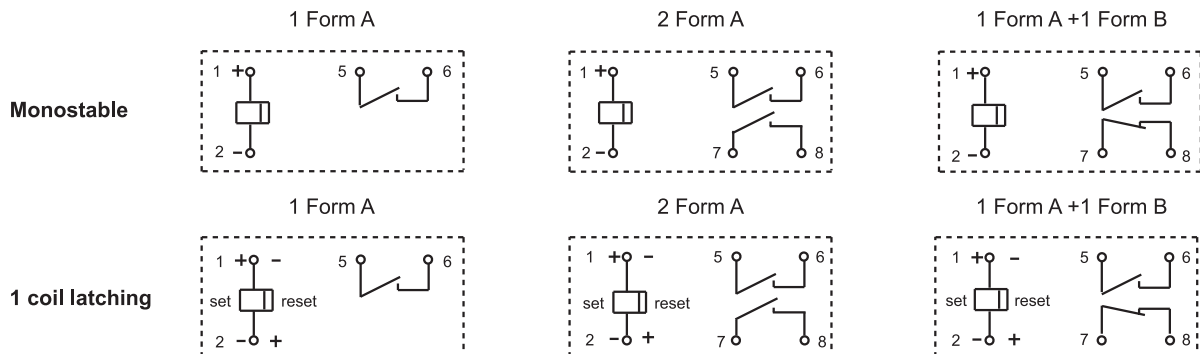
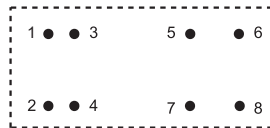

# OUTLINE DIMENSIONS, WIRING DIAGRAM AND PCB LAYOUT

Unit: mm

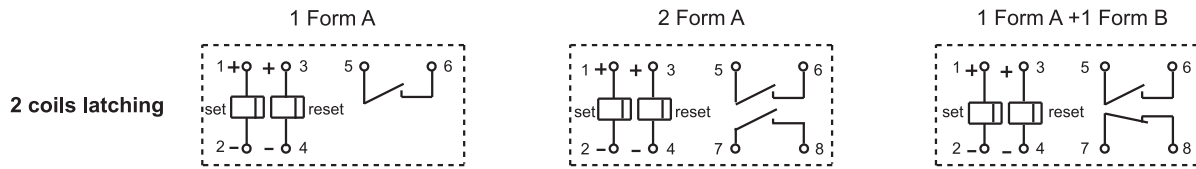

Remark: The above is wiring diagram for product with standard polarity, the coil polarity of reverse polarity and standard polarity is opposite.

## CHARACTERISTIC CURVES

### MAXIMUM SWITCHING POWER

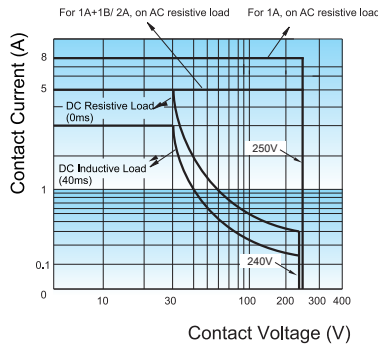

### ENDURANCE CURVE

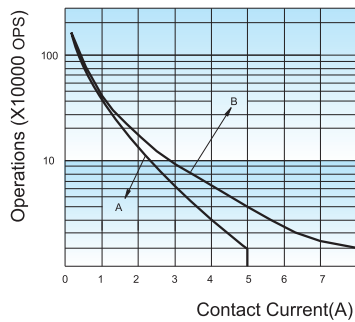

### COIL TEMPERATURE RISE

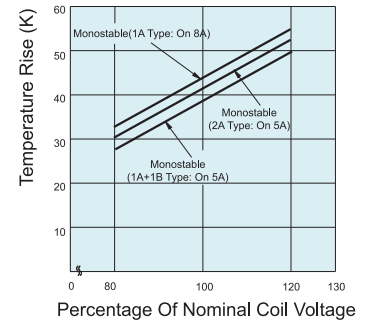

#### Test conditions:

- Curve A: 1A+1B type (or 2A type)  
Curve B: 1A type
- Test conditions:  
Resistive load, 120VAC~250VAC, 40°C.

#### Operate & Release Time

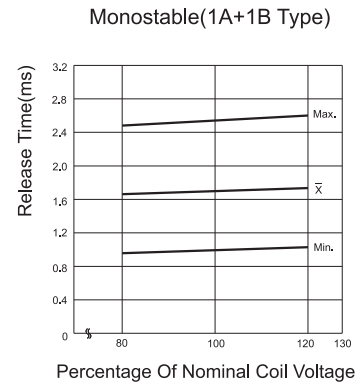
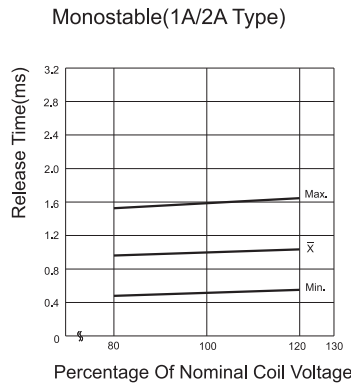
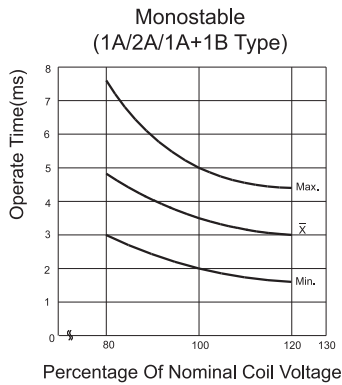

#### Operate & Release Voltage

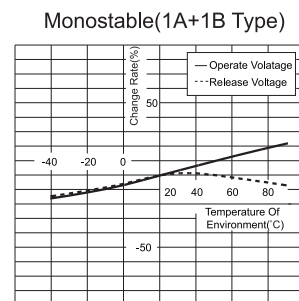
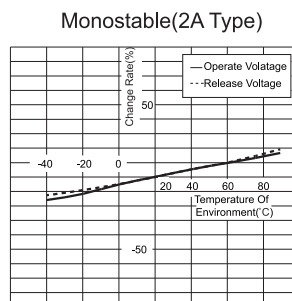
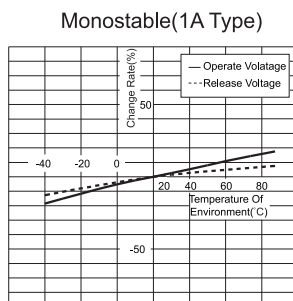

## CAUTIONS

1. Latching relay is on the "reset" or "set" status when delivery, with the consideration of shock risen from transit and relay mounting, relay would be changed to "set" or "reset" status, therefore, when application ( connecting the power supply), please reset the relay to "set" or "reset" status on request.
2. In order to maintain "set" or "reset" status, energized voltage applied across the coil should reach the rated voltage, impulse width should be 5 times more than "set" or "reset" time. Do not energize voltage to "set" coil and "reset" coil simultaneously. And also long energized time (more than 1 min) should be avoided.
3. The recommended soldering temperature range is  $250\pm 10^{\circ}\text{C}$  with the duration of 2~5s for PCB termination. It is not suggested to apply reflow soldering method, if it is required indeed, please contact with our technicians. It is general required that the wave soldering temperature at  $250^{\circ}\text{C}$  shall not more than 2s. the below chart is the wave soldering temperature distribution chart we recommended for your reference.
4. Keep the product away from strong magnetic field during transportation, storage and application, to avoid change of set/reset voltage.
5. This is a polarized relay. Please pay attention to the coil polarity according to the datasheet when using it.

Wave soldering temperature distribution chart

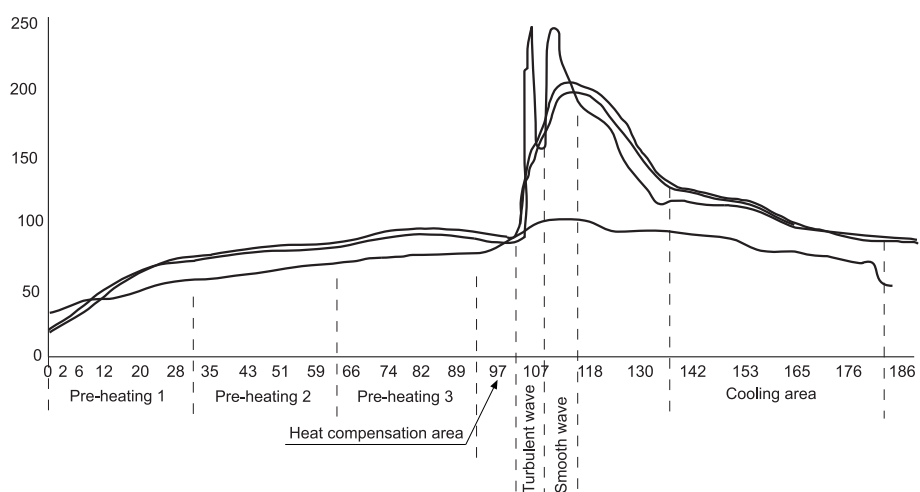

### Disclaimer

The specification is for reference only. Specifications subject to change without notice.

We could not evaluate all the performance and all the parameters for every possible application. Thus the user should be in a right position to choose the suitable product for their own application. If there is any query, please contact Hongfa for the technical service. However, it is the user's responsibility to determine which product should be used only.