

41F-1Z-C10

RELAY SOCKETS

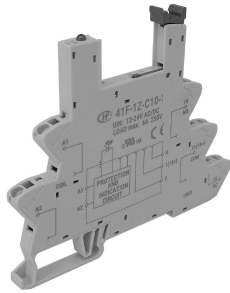

Features

- The dielectric strength can reach 4000VAC and the insulation resistance is 1000MΩ
- With finger protection device
- Ensure secure retention and easy ejection of relays
- Built-in protection circuit can indicate the power status, protect the circuit and expand the range of relay input voltage
- Maximum Line Diameter: Hard wire and sleeve wire
- Components available: marker, jumper and separator

CONTACT DATA

Type	Nominal Voltage	Nominal Current	Ambient Temperature	Input Voltage	Relay's Applicable Rated Voltage	Polarity of Input Voltage	Screw Torque
41F-1Z-C10-1	250VAC	6A	-40°C~70°C	(12-24)VAC/DC	(12-24)VDC	No requirement	10 mm
41F-1Z-C10-2			-40°C~70°C	(48-60)VAC/DC	(48-60)VDC	No requirement	10 mm
41F-1Z-C10-3			-40°C~55°C	(110-125)VAC/DC	60VDC	No requirement	10 mm
41F-1Z-C10-4			-40°C~55°C	(220-240)VAC/DC	60VDC	No requirement	10 mm
41F-1Z-C10-5			-40°C~70°C	(6-24)VDC	(6-24)VDC	Requirement	10 mm

OUTLINE DIMENSIONS, WIRING DIAGRAM AND PC BOARD LAYOUT

Socket (If you need accessories, please order separately)	Outline Dimensions	Wiring Diagram / PCB Layout	Accessory Available
			<p>*marker: 41F-M 41F-M1</p> <p>*jumper : 41F-J1(bule) 41F-J1R (red) 41F-J1B (black)</p> <p>*separator: 41F-S</p>

DIMENSION OF RELATED ACCESSORY (AVAILABLE)

单位: mm

Maker

41F-M

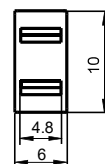

HONGFA RELAY

ISO9001、IATF16949、ISO14001、OHSAS18001、IECQ QC 080000 CERTIFIED

2021 Rev. 1.00

41F-M1

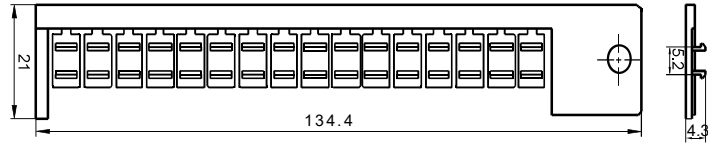

Jumper :

- 41F-J1(bule)
- 41F-J1R (red)
- 41F-J1B (black)

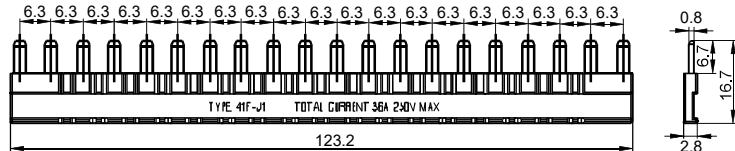

separator:

41F-S

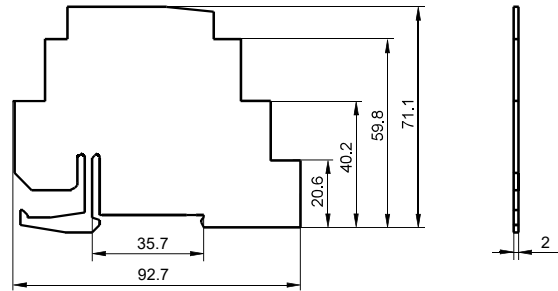

Things to be noticed when selecting sockets:

1. Please choose suitable relay socket according to the actual mounting environment, relay contact poles and terminal layout. If there is any query on selection, please contact Hongfa for the technical service.
2. As for related components, they should be selected separately. Please do give clear indication of the types of relay sockets and related components you choose while placing order.
3. Main outline dimension(L, W, H) ≥50mm, tolerance should be ±1mm; outline dimension >20mm and <50mm, tolerance should be ±0.5mm;outline dimension ≤20mm, tolerance should be ±0.3mm.
4. DIN rail mounting: recommend to use standard rail 35×7.5×1, 35×15×1.

PRECAUTIONS FOR USE

1. Please use the quick-break fuse with rating of 15Amp. for short-circuit protection.
2. It may cause failure, fire or malfunction, when the sockets is continuously applied the power to for a long term In case of exceeding the upper limit ambient temperature. So please ensure that the ambient temperature is within the upper limit when using sockets.

Operating temperature upper limit: 55oC: 41F-1Z-C10-3/4
 Operating temperature upper limit: 70oC: 41F-1Z-C10-1/2/5

3. Things to be noticed when selecting soft wiring.

• The soft wiring can be divided into the following types.

1.5mm² below or AWG16 below the Conductor with sleeve or a single wire

Be sure to use this size that the front end of the wire needs to be stripped of the 8mm~10mm insulation protection layer. length with Conductor with sleeve ≥ 10mm

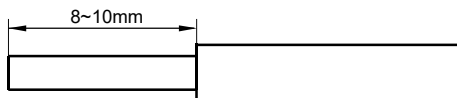

Figure 1

PRECAUTIONS FOR USE

- If the stripping protective layer is too short, it may cause the wire to be pulled out. If it is too long, it may have a short circuit with the adjacent wire. If the stranded wire of cold pressed terminal is used, please tighten the wire of stranded wire before use to avoid loose wire.

Use the recommended screwdriver specifications when wiring.

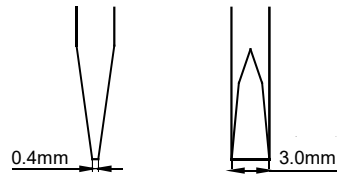

Figure 2

- The insertion position of the wire and the screwdriver and the insertion direction of the screwdriver are as shown in Figure 3.

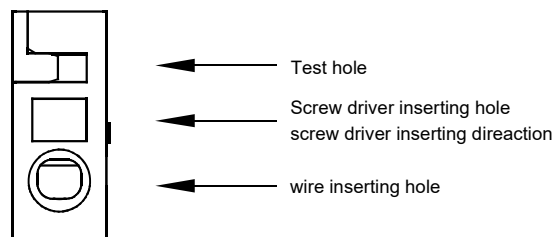

Figure 3

- Please use cold pressed terminals when selecting twisted line.

- The method of Wiring as shown in figure 4.

Insert the wire into the wire insertion hole (circular hole) in the direction of (1) arrow, and insert the wire straight into the bottom, as shown in (2).

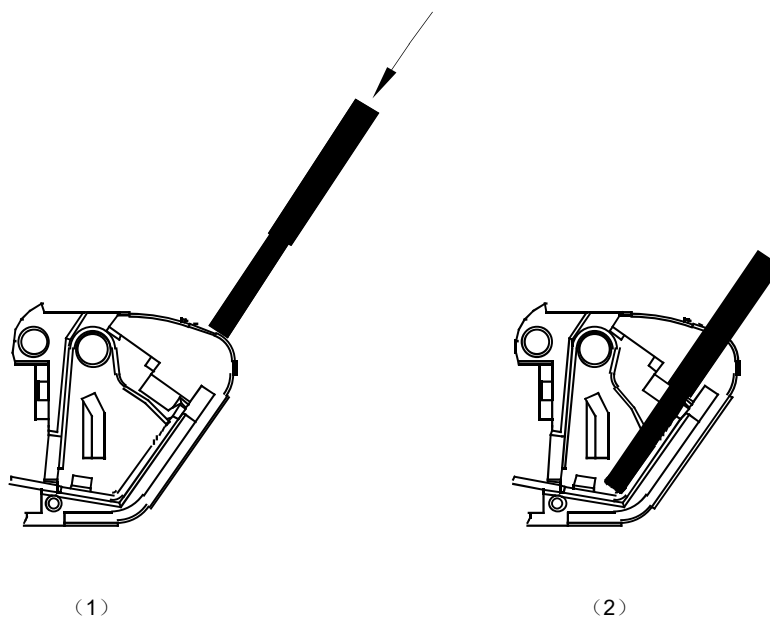

Figure 4

PRECAUTIONS FOR USE

- The method of Wiring as stitching in figure 5.

Insert the wire into the wire insertion hole (circular hole) in the direction of (1) arrow, and insert the wire straight into the bottom, as shown in (2).

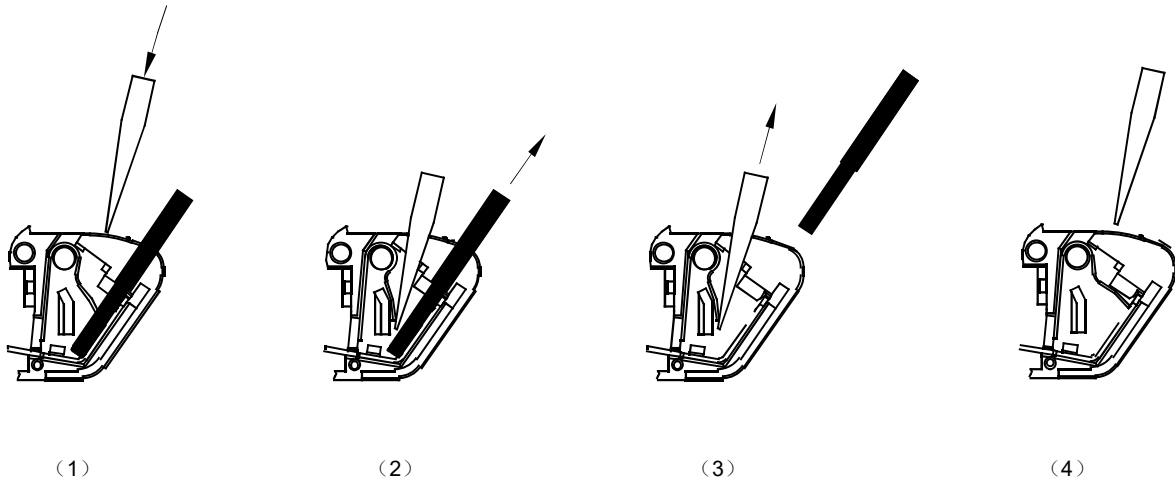

Figure 5

4. Mounting relay.

Presents the socket anti-stripping spring in an open state (see Figure 6), and aligns the relay to the main socket cavity (Figure 7). Then turn the buckle counterclockwise and press the relay gently until it is fully plugged into the socket (Figure 8).

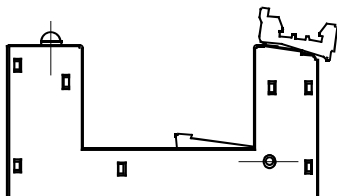

Figure 6

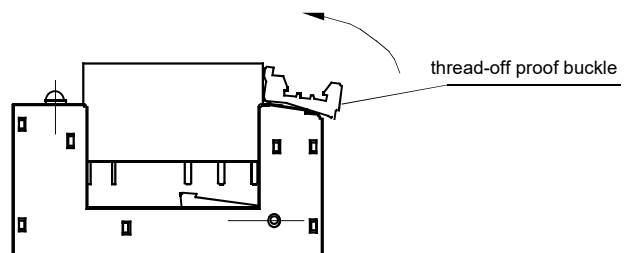

Figure 7

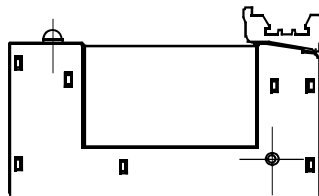

Figure 8

5. Disassembly relay.

Disconnect the relay by pulling the anti lock buckle of the socket clockwise (please refer to the pictures attached for more details)

PRECAUTIONS FOR USE

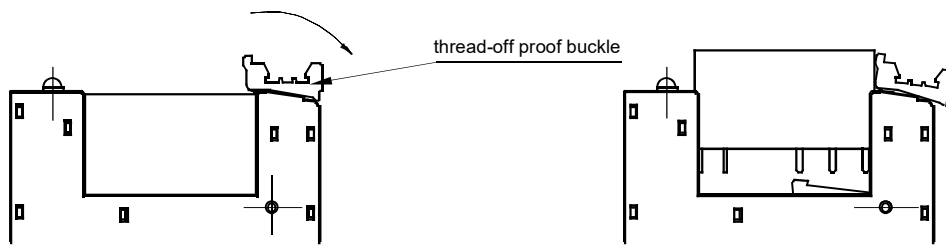

Figure 9

Figure 10

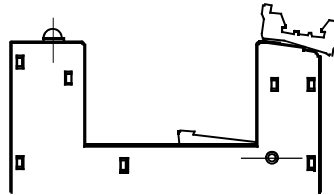

Figure 11

6. Installation socket And Disassembly socket.

Insert the A of the socket into the rail and press it in the direction of the arrow.(Figure 12)

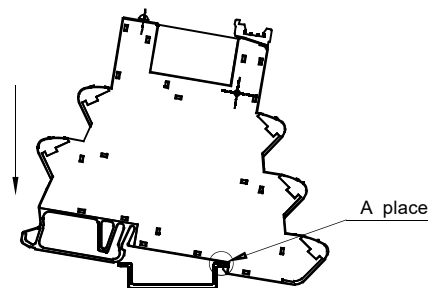

Figure 12

Insert a screwdriver into B, turn in the direction of the arrow, lift the socket and remove the socket.(Figure 12).

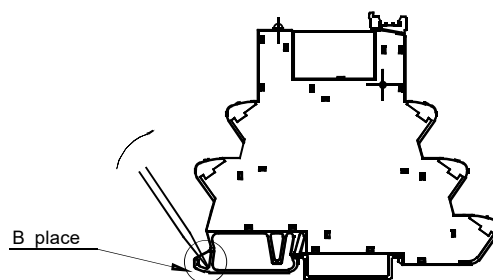

Figure 13

Disclaimer

The specification is for reference only. See to "Terminology and Guidelines" for more information. Specifications subject to change without notice. We could not evaluate all the performance and all the parameters for every possible application. Thus the user should be in a right position to choose the suitable product for their own application. If there is any query, please contact Hongfa for the technical service. However, it is the user's responsibility to determine which product should be used only.

© Xiamen Hongfa Electroacoustic Co., Ltd. All rights of Hongfa are reserved.