

# HF32FA-T

## SUBMINIATURE INTERMEDIATE HIGH TEMPERATURE POWER RELAY



File No.:E134517



File No.:40006182



File No.:CQC09002028689(Compliant with GB/T 14536.1-2022;GB/T21711.1-2023)  
CQC23001382245(Compliant with GB 4943.1-2022;IEC 61810-1:2015)

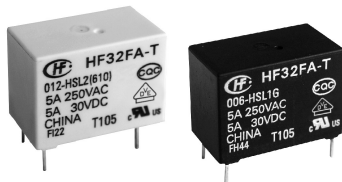

### Features

- High temperature: 105°C
- 5A switching capability
- 1 Form A configuration
- Creepage/clearance distance>8mm
- 5kV dielectric strength (between coil and contacts)
- UL insulation system: Class F
- Meeting VDE 0700, 0631 reinforce insulation
- Product in accordance to IEC 60335-1 available

### CONTACT DATA

Contact arrangement	1A
Contact resistance <sup>1)</sup>	70mΩ max.(at 1A 6VDC)
Contact material	AgNi
Contact rating (Res. load)	5A 250VAC 5A 30VDC
Max. switching voltage	250VAC/30VDC
Max. switching current	5A
Max. switching power	1250VA/150W
Mechanical endurance	1 x 10 <sup>5</sup> OPS
Electrical endurance	1 x 10 <sup>5</sup> OPS ( 5A 250VAC, Resistive load, Room temp., 1.5s on 1.5s off)

Notes:1) The data shown above are initial values.

### CHARACTERISTICS

Insulation resistance	1000MΩ (at 500VDC)	
Dielectric strength	Between coil & contacts	5000VAC 1min
	Between open contacts	1000VAC 1min
Operate time (at rated. volt.)	8ms max.	
Release time (at rated. volt.)	4ms max.	
Humidity	5% to 85% RH	
Ambient temperature	-40°C to 105°C	
Shock resistance*	Functional	98m/s <sup>2</sup>
	Destructive	980m/s <sup>2</sup>
Vibration resistance*	10Hz to 55Hz 1.65mm DA	
Termination	PCB	
Unit weight	Approx.4.6g	
Construction	Plastic sealed, Flux proofed	

- Notes: 1) \*Index is not in relay length direction.  
2) The data shown above are initial values.  
3) Please find coil temperature curve in the characteristic curves below.

### COIL

Coil power	Sensitive: Approx. 200mW
------------	--------------------------

### COIL DATA

at 23°C

#### Sensitive type

Nominal Voltage VDC	Pick-up Voltage VDC max. <sup>1)</sup>	Drop-out Voltage VDC min. <sup>1)</sup>	Max. Voltage VDC * <sup>2)</sup>	Coil Resistance Ω
3	2.25	0.15	5.1	45 x (1±10%)
5	3.75	0.25	8.5	125 x (1±10%)
6	4.50	0.30	10.2	180 x (1±10%)
9	6.75	0.45	15.3	400 x (1±10%)
12	9.00	0.60	20.4	720 x (1±10%)
18	13.5	0.90	30.6	1600 x (1±10%)
24	18.0	1.20	40.8	2800 x (1±10%)

- Notes: 1) The data shown above are initial values.  
2) \* Maximum voltage refers to the maximum voltage which relay coil could endure in a short period of time.

### SAFETY APPROVAL RATINGS

UL/CUL	5A 250VAC
VDE	5A 250VAC at 105°C 3A 400VAC at 105°C

- Notes: 1) All values unspecified are at room temperature.  
2) Only typical loads are listed above. Other load specifications can be available upon request.



HONGFA RELAY

ISO9001, IATF16949, ISO14001, ISO45001, IECQ QC 080000, ISO/IEC 27001 CERTIFIED

2026 Rev. 1.00

## ORDERING INFORMATION

Type	HF32FA-T / 012 -H S L 1 G (XXX)					
Coil voltage	3, 5, 6, 9, 12, 18, 24VDC					
Contact arrangement	H: 1 Form A					
Construction <sup>1)2)</sup>	S: Plastic sealed		Nil: Flux proofed			
Coil power	L: Sensitive					
Termination	1: Type 1		2: Type 2			
Contact plating <sup>3)</sup>	G: Gold plated		Nil: No gold plated			
Special code <sup>4)</sup>	XXX: Customer special requirement		Nil: Standard			

- Notes:** 1) We recommend flux proofed types for a clean environment (free from contaminations like H<sub>2</sub>S, SO<sub>2</sub>, NO<sub>2</sub>, dust, etc.). We suggest to choose plastic sealed types and validate it in real application for an unclean environment (with contaminations like H<sub>2</sub>S, SO<sub>2</sub>, NO<sub>2</sub>, dust, etc).  
 2) Contact is recommended for suitable condition and specifications if water cleaning or surface process is involved in assembling relays on PCB.  
 3) For gold plated type, the min. switching current and min. switching voltage is 10mA 5VDC.  
 4) The customer special requirement express as special code after evaluating by Hongfa. e.g.(335) stands for product in accordance to IEC 60335-1 (GWT). 6) For products that should meet the explosion-proof requirements of "IEC 60079 series", please note [Ex] after the specification while placing orders. Not all products have explosion-proof certification, so please contact us if necessary, in order to select the suitable products.  
 5) Two packing methods available: paper box package, tube package, Standard tube packing length is 535mm. Any special requirement needed, please contact us for more details.

## OUTLINE DIMENSIONS, WIRING DIAGRAM AND PC BOARD LAYOUT

Unit: mm

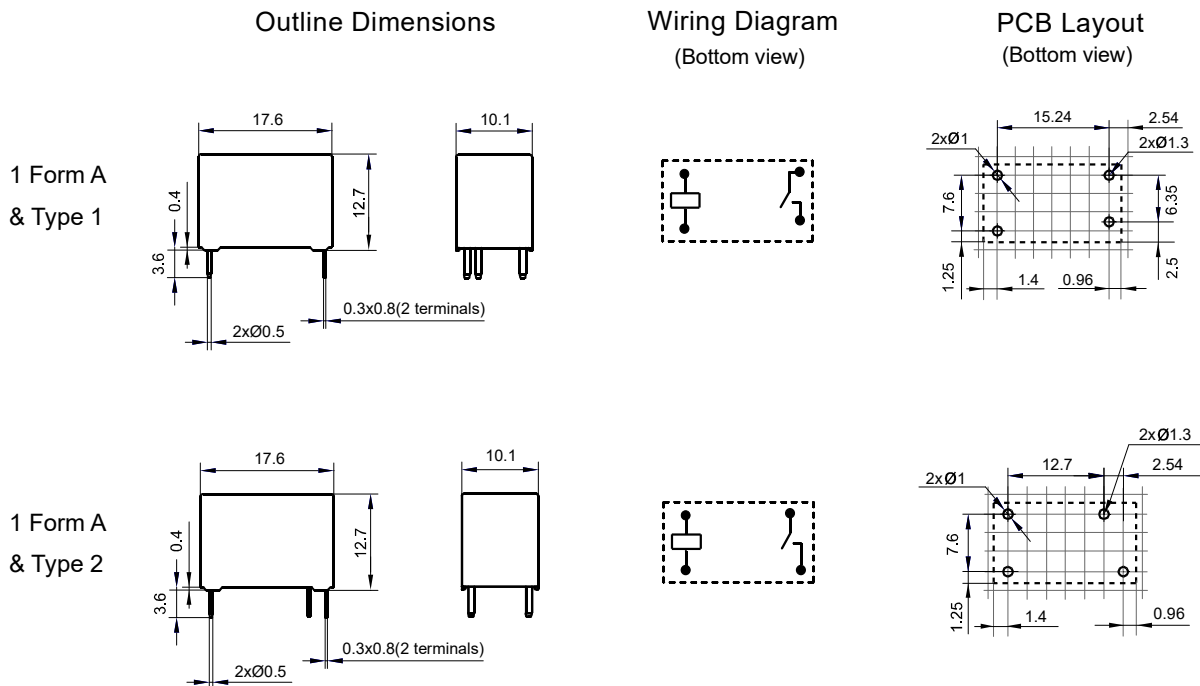

- Remark: 1) In case of no tolerance shown in outline dimension: outline dimension  $\leq 1\text{mm}$ , tolerance should be  $\pm 0.2\text{mm}$ ; outline dimension  $> 1\text{mm}$  and  $\leq 5\text{mm}$ , tolerance should be  $\pm 0.3\text{mm}$ ; outline dimension  $> 5\text{mm}$ , tolerance should be  $\pm 0.4\text{mm}$ .  
 2) The tolerance without indicating for PCB layout is always  $\pm 0.1\text{mm}$ .  
 3) The width of the gridding is 2.54mm.

## CHARACTERISTIC CURVES

MAXIMUM SWITCHING POWER

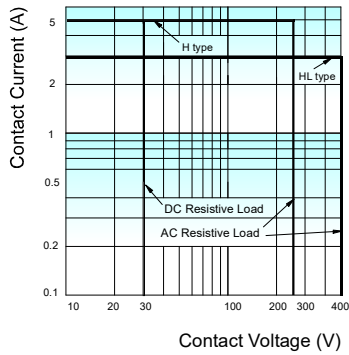

ENDURANCE CURVE

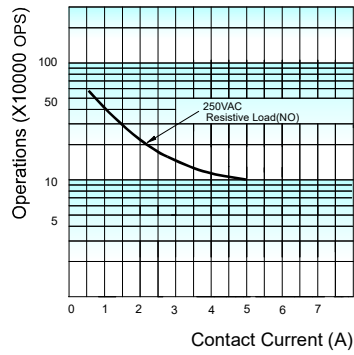

Test conditions: Flux proofed,  
Room temp., 1.5s on 1.5s off

TEMPERATURE RISE

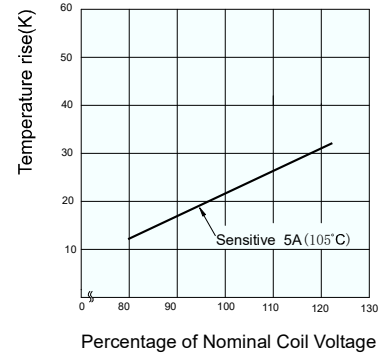

### Disclaimer

The specification is for reference only. See to "Terminology and Guidelines" for more information. Specifications subject to change without notice. We could not evaluate all the performance and all the parameters for every possible application. Thus the user should be in a right position to choose the suitable product for their own application. If there is any query, please contact Hongfa for the technical service. However, it is the user's responsibility to determine which product should be used only.

© Xiamen Hongfa Electroacoustic Co., Ltd. All rights of Hongfa are reserved.