

# HF46F-G

## SUBMINIATURE INTERMEDIATE POWER RELAY



File No.: E134517



File No.: 40025215



File No.: CQC08001024932(Complies with GB/T 14536.1-2022, GB/T 21711.1-2023 standard)  
CQC23001377588(Complies with GB 4943.1-2022, IEC 61810-1:2015 standard)



### Features

- 10A switching capability
- Meets VDE 0631 reinforce insulation
- Highly efficient magnetic circuit for high sensitivity: 200mW
- Extremely small footprint utilizing PCB area
- UL insulation system: Class F

**RoHS compliant**

### CONTACT DATA

Contact arrangement	1A
Contact resistance <sup>1)</sup>	100mΩ max.(at 1A 6VDC)
Contact material	AgSnO <sub>2</sub> , AgNi
Contact rating (Res. load)	7A 250VAC / 30VDC 10A 250VAC / 30VDC
Max. switching voltage	277VAC / 30VDC
Max. switching current	10A
Max. switching power	2770VA / 300W
Mechanical endurance	5 x 10 <sup>6</sup> OPS
Electrical endurance	5 x 10 <sup>4</sup> OPS (7A 250VAC, Resistive load, AgNi, at 105°C, 3s on 3s off) 6 x 10 <sup>4</sup> OPS (7A 250VAC, Resistive load, AgSnO <sub>2</sub> , at 85°C, 3s on 3s off) 1 x 10 <sup>4</sup> OPS (10A 250VAC, Resistive load, AgNi, at 85°C, 1s on 9s off) 1 x 10 <sup>4</sup> OPS (10A 250VAC, Resistive load, AgSnO <sub>2</sub> , at 85°C, 1s on 9s off)

Notes: 1) The data shown above are initial values.

### CHARACTERISTICS

Insulation resistance	1000MΩ (at 500VDC)	
Dielectric strength	Between coil & contacts	4000VAC 1min
	Between open contacts	1000VAC 1min
Operate time (at rated. volt.)	10ms max.	
Release time (at rated. volt.)	10ms max.	
Shock resistance <sup>1)</sup>	Functional	98m/s <sup>2</sup>
	Destructive	980m/s
Vibration resistance <sup>1)</sup>	10Hz to 55Hz 1.5mm DA	
Humidity	5% to 85% RH	
Ambient temperature	-40°C to 85°C	
Termination	PCB	
Unit weight	Approx. 3g	
Construction	Plastic sealed	

Notes: 1) Shock malfunction: 49m/s<sup>2</sup> for the length direction.  
Vibration: 10Hz to 55Hz 1mm DA for the length direction.  
2) The data shown above are initial values.

### COIL

Coil power	Approx. 200mW
------------	---------------

### COIL DATA

at 23°C

Nominal Voltage VDC	Pick-up Voltage VDC max. <sup>1)</sup>	Drop-out Voltage VDC min. <sup>1)</sup>	Max. Voltage VDC * <sup>2)</sup>	Coil Resistance Ω
3	2.25	0.18	3.90	45 x (1±10%)
5	3.75	0.25	6.50	125 x (1±10%)
6	4.50	0.30	7.80	180 x (1±10%)
9	6.75	0.45	11.7	405 x (1±10%)
12	9.00	0.60	15.6	720 x (1±10%)
18	13.5	0.90	23.4	1620 x (1±10%)
24	18.0	1.20	31.2	2880 x (1±10%)

Notes: 1) The data shown above are initial values.

2) \* Maximum voltage refers to the maximum voltage which relay coil could endure in a short period of time.

### SAFETY APPROVAL RATINGS

UL/CUL	AgNi	10A 125VAC/250VAC at 85°C 10A 277VAC/30VDC at 85°C 7A 125VAC/250VAC at 105°C 7A 277VAC/30VDC at 105°C
	AgSnO <sub>2</sub>	10A 125VAC/250VAC at 85°C 10A 277VAC/30VDC at 85°C 7A 125VAC/250VAC at 85°C 7A 277VAC/30VDC at 85°C TV-3
VDE	AgNi	7A 250VAC/30VDC at 105°C 10A 250VAC/30VDC at 85°C
	AgSnO <sub>2</sub>	7A 250VAC/30VDC at 85°C 10A 250VAC/30VDC at 85°C

Notes: 1) All values unspecified are at room temperature.

2) Only typical loads are listed above. Other load specifications can be available upon request.



HONGFA RELAY

ISO9001, IATF16949, ISO14001, ISO45001, IECQ QC 080000, ISO/IEC 27001 CERTIFIED

2025 Rev. 2.00

## ORDERING INFORMATION

Type	HF46F-G / 12 -H S 1 T G F (XXX)
Coil voltage	3, 5, 6, 9, 12, 18, 24VDC
Contact arrangement	H: 1 Form A
Construction <sup>1)2)</sup>	S: Plastic sealed
Termination	1: type 1
Contact material <sup>3)</sup>	T: AgSnO <sub>2</sub> Nil: AgNi
Contact plating	G: Gold plated Nil: No gold plated
Insulation standard	F: Class F Nil: Class F
Special code <sup>5)</sup>	XXX: Customer special requirement Nil: Standard

- Notes:** 1) We suggest to choose plastic sealed types and validate it in real application for an unclean environment (with contaminations like H<sub>2</sub>S, SO<sub>2</sub>, NO<sub>2</sub>, dust, etc).  
 2) Contact is recommended for suitable condition and specifications if water cleaning or surface process is involved in assembling relays on PCB.  
 3) For the loads which can bring high inrush current when relay contacts connect instantly (eg. lamp, capacitive load), AgSnO<sub>2</sub> contact material is recommended on priority.  
 4) For gold plated type, the min. switching current and min. switching voltage is 10mA 5VDC.  
 5) The customer special requirement express as special code after evaluating by Hongfa.  
 6) Two packing methods available: paper box package, plastic tray package, tube package. Standard tube packing length is 560mm. Any special requirement needed, please contact us for more details.  
 7) For products that should meet the explosion-proof requirements of "IEC 60079 series", please note [Ex] after the specification while placing orders. Not all products have explosion-proof certification, so please contact us if necessary, in order to select the suitable products.

## OUTLINE DIMENSIONS, WIRING DIAGRAM AND PC BOARD LAYOUT

Unit: mm

### Outline Dimensions

HF46F-G/□□ -HS1□□ (XXX)

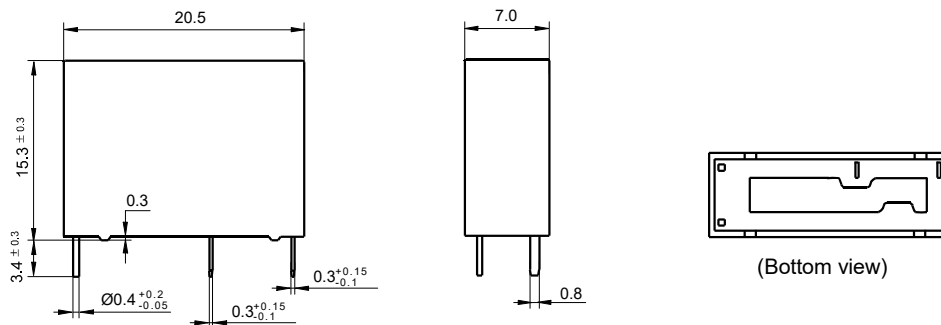

### PCB Layout (Bottom view)

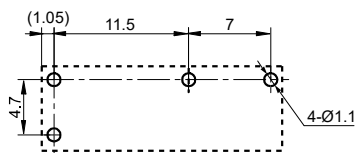

### Wiring Diagram (Bottom view)

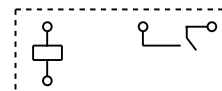

- Remark:** 1) The pin dimension of the product outline drawing is the size before tinning (it will become larger after tinning), and the mounting hole size is the recommended design size of the PCB board hole. The specific PCB board hole design size can be mapped and adjusted according to the actual product.  
 2) In case of no tolerance shown in outline dimension: outline dimension ≤ 1mm, tolerance should be ±0.2mm; outline dimension > 1mm and ≤ 5mm, tolerance should be ±0.3mm; outline dimension > 5mm, tolerance should be ±0.4mm.  
 3) The tolerance without indicating for PCB layout is always ±0.1mm.

## CHARACTERISTIC CURVES

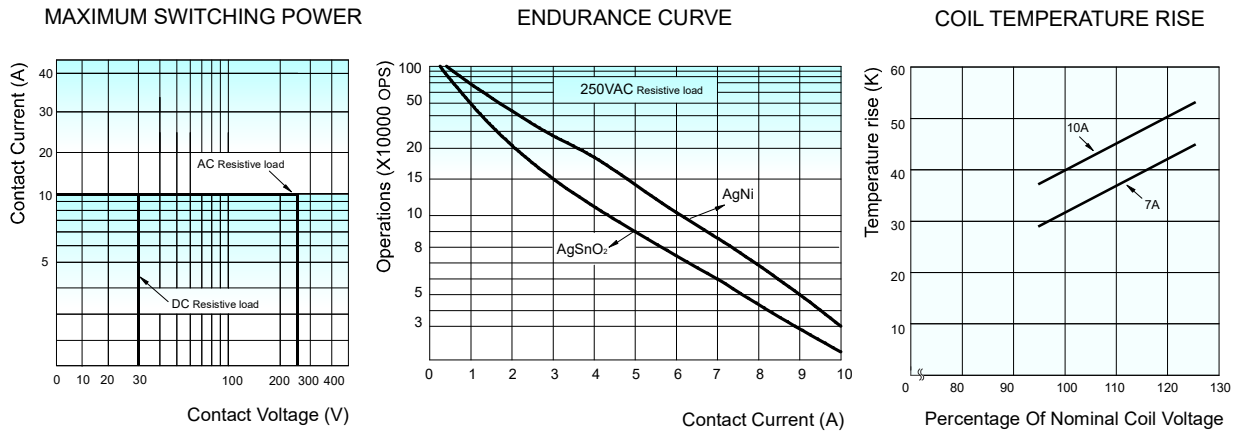

**Test conditions:** at 85°C, 3s on 3s off

### Disclaimer

The specification is for reference only. See to "Terminology and Guidelines" for more information. Specifications subject to change without notice. We could not evaluate all the performance and all the parameters for every possible application. Thus the user should be in a right position to choose the suitable product for their own application. If there is any query, please contact Hongfa for the technical service. However, it is the user's responsibility to determine which product should be used only.

© Xiamen Hongfa Electroacoustic Co., Ltd. All rights of Hongfa are reserved.