

# HFD16

# SUBMINIATURE SIGNAL RELAY



File No.: E133481



File No.: R50374275



### Features

- 8A switching capability
- UL insulation system: Class F
- Epoxy sealed for automatic-wavesoldering and cleaning
- Standard PCB layout
- Product in accordance to IEC 60335-1 available
- Products compliant with IEC 60079 available
- 1.5kV dielectric strength between coil & contacts is available

**RoHS compliant**

### CONTACT DATA

Contact arrangement	1A, 1C
Contact resistance <sup>1)</sup>	100mΩ max. (AgNi gold-plated specifications: 0.1A 30mVDC, AgNi non gold-plated specifications and AgSnO <sub>2</sub> : 1A 30mVDC)
Contact material	AgNi, AgSnO <sub>2</sub>
Contact rating (Res. load)	3A 30VDC 3A 250VAC
Max. switching voltage	250VAC / 220VDC
Max. switching current	8A(30VDC)
Max. switching power	750VA / 90W
Min. applicable load	5V 1mA (Suitable for AgNi gold-plated specifications)
Mechanical endurance	1 x 10 <sup>7</sup> OPS
Electrical endurance	<p><b>1C type:</b> 1 x 10<sup>5</sup> OPS (NO: AgNi, 85°C, 1s on 9s off, 3A 30VDC) 5 x 10<sup>4</sup> OPS (NO: AgNi, Room temp, 1s on 9s off, 3A 250VAC)</p> <p><b>1A type:</b> 2 x 10<sup>5</sup> OPS (NO: AgNi, 85°C, 1s on 9s off, 3A 30VDC) 1 x 10<sup>5</sup> OPS (NO: AgNi, 85°C, 1s on 9s off, 3A 250VAC)</p>

- Notes:** 1) The data shown above are initial values.  
 2) Min. applicable load is reference value. Please perform the confirmation test with the actual load before production since reference value may change according to switching frequencies, environmental conditions and expected contact resistance and reliability.

### COIL

Coil power	C type: 150mW; H type: 200mW
------------	------------------------------

### COIL DATA

23°C

High sensitive type: (200mW)

Nominal Voltage VDC	Initial Pick-up Voltage VDC max.	Initial Drop-out Voltage VDC min.	Max. Voltage <sup>5)</sup> VDC	Coil Resistance x (1±10%) Ω
2.4	1.80	0.24	4.8	28.8
3	2.25	0.3	6.0	45.0
4.5	3.38	0.45	9.0	101.3
5	3.75	0.5	10	120
6	4.50	0.6	12	180
9	6.75	0.9	18	400
12	9.00	1.2	24	700
18	13.5	1.8	36	1620
24	18.0	2.4	48	2800

Super sensitive type: (150mW)

Nominal Voltage VDC	Initial Pick-up Voltage VDC max.	Initial Drop-out Voltage VDC min.	Max. Voltage <sup>5)</sup> VDC	Coil Resistance x (1±10%) Ω
2.4	1.92	0.24	4.8	38.4
3	2.40	0.3	6.0	60.0
4.5	3.60	0.45	9.0	135
5	4.00	0.5	10	166.7
6	4.80	0.6	12	240
9	7.20	0.9	18	540
12	9.60	1.2	24	960
18	14.4	1.8	36	2160
24	19.2	2.4	48	3840



HONGFA RELAY

ISO9001, IATF16949, ISO14001, ISO45001, IECQ QC 080000, ISO/IEC 27001 CERTIFIED

2025 Rev. 1.01

## COIL DATA

23°C

**Notes:** 1) The data shown above are initial values.

2) To supply rated step voltage to coil is the foundation of relay proper operation. Please make sure the applied voltage to the coil reach at rated values.

Please refer to the typical diagram below for single side stable relay. The "V\_coil" is the rated voltage.:

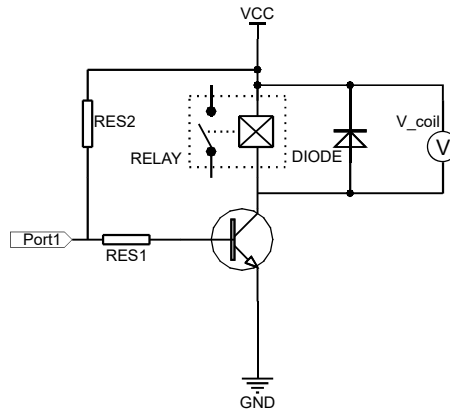

3) In case 5V of transistor drive circuit, it is recommended to use 4.5V type relay, and 3V to use 2.4V type relay.

4) For monostable relays, if you need to drop down voltage and hold mode after reliably operating, make sure that the effective value of holding voltage is not less than 60% of the rated voltage.

5) Maximum voltage refers to the maximum voltage which relay coil could endure in a short period of time.

6) When user's requirements can't be found in the above table, special order allowed.

7) During the relay pick-up or drop-out processes, there are stages of contact pressure change, contact vibration and unstable contact etc. When the voltage applied to coil is gradually changed, it will lengthen the unstable stage and affect relay endurance. To reduce this influence, please apply step voltage (switching circuit) to relay coil.

## SAFETY APPROVAL RATINGS

UL/CUL	H High sensitive type	AgNi	3A 30VDC,85°C 3A 250VAC 5A 125VAC 1A 125VAC,85°C
		AgSnO <sub>2</sub>	3A 30VDC,85°C 3A 250VAC 1A 250VAC,85°C TV-1 125VAC
	C Super sensitive type	AgNi	3A 250VAC 3A 30VDC,85°C
		AgSnO <sub>2</sub>	3A 250VAC 3A 30VDC,85°C TV-1 125VAC
TÜV	H High sensitive type	AgNi	3A 30VDC ,85°C 3A 250VAC 1A 250VAC 1A 125VAC,85°C 5A 125VAC
		AgSnO <sub>2</sub>	3A 30VDC,85°C 3A 250VAC 1A 250VAC,85°C 1(1)A 250VAC

**Notes:** 1) All values unspecified are at room temperature.

2) Only typical loads are listed above. Other load specifications can be available upon request.

## ORDERING INFORMATION

Type	HFD16/	24	-Z	H	-3	N	(XXX)
Coil voltage	2.4, 3, 4.5, 5, 6, 9, 12, 18, 24 VDC						
Contact arrangement	H: 1 Form A		Z: 1 Form C				
Coil power	C: Super sensitive(150mW)		H: High sensitive(200mW)				
Contact material	3: AgNi		T: AgSnO <sub>2</sub>				
Contact plating	Nil: gold plated(Only for AgNi type)		N: No gold plated				
Special code <sup>2)</sup>	XXX: Customer special requirement		Nil: Standard				
	For instance: Product with 413 suffix is indicate dielectric withstand voltage between coil and contact $\geq 1500$ VAC 1 min.						

Notes: 1) This product is suitable for wave soldering or manual soldering.

2) The customer special requirement express as special code after evaluating by Hongfa.

3) The standard size of this product tube package is 409mm, Any special requirement needed, please contact us for more details.

4) For products that should meet the explosion-proof requirements of "IEC 60079 series", please note [Ex] after the specification while placing orders. Not all products have explosion-proof certification, so please contact us if necessary, in order to select the suitable products.

## OUTLINE DIMENSIONS, WIRING DIAGRAM AND PC BOARD LAYOUT

Unit: mm

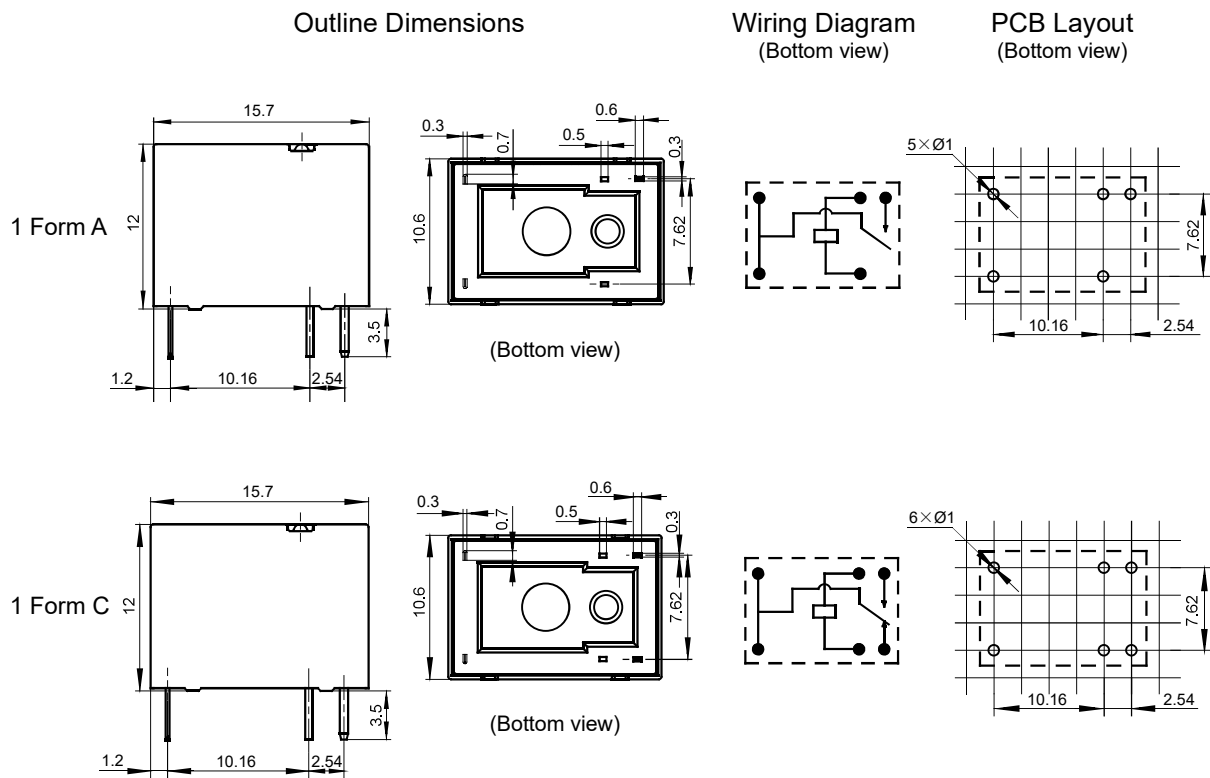

Remark: 1) The pin dimension of the product outline drawing is the size before tinning(it will become larger after tinning),and the mounting hole size is the recommended design size of the PCB board hole.The specific PCB board hole design size can be mapped and adjusted according to the actual product.

2) In case of no tolerance shown in outline dimension: outline dimension  $\leq 1$ mm, tolerance should be  $\pm 0.2$ mm;

outline dimension  $> 1$ mm and  $\leq 5$ mm, tolerance should be  $\pm 0.3$ mm; outline dimension  $> 5$ mm, tolerance should be  $\pm 0.4$ mm.

3) The tolerance without indicating for PCB layout is always  $\pm 1$ mm.

4) The width of the gridding is 2.54mm.

## CHARACTERISTIC CURVES

MAXIMUM SWITCHING POWER

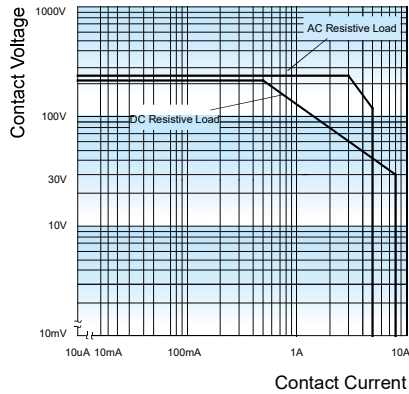

ENDURANCE CURVE

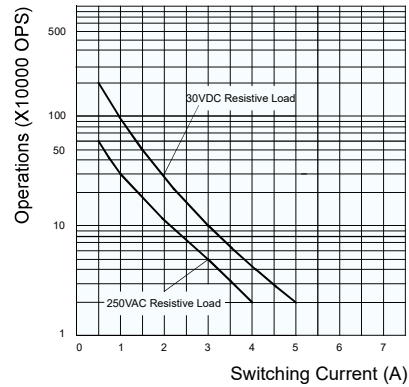

**Test conditions:**

NO:AgNi,Resistive Load,85°C,1s on 9s off.

**Notice**

- 1) To avoid using relays under strong magnetic field which will change the parameters of relays such as pick-up voltage and drop-out voltage.
- 2) Energizing coil with rated voltage is basic for normal operation of a relay, please make sure the energized voltage to relay coil have reached the rated voltage. Regarding latching relay, in order to maintain the "set" or "reset" status, impulse width of the rated voltage applied to coil should be more than 5 times of "set" or "reset" time.
- 3) For a monosteady state relay, after the relay is reliably operated, if it needs to be kept under pressure, make sure that the effective value of the voltage is not less than 60% of the rated voltage;
- 4) The relay may be damaged because of falling or when shocking conditions exceed the requirement.
- 5) Please use wave soldering or manual soldering for straight-in relay. If you need reflow welding, please confirm the feasibility with us.
- 6) Contact is recommended for suitable condition and specifications if water cleaning or surface process is involved in assembling relays on PCB.
- 7) Plastic sealed type is recommended for an environment with noxious gas such as H<sub>2</sub>S, SO<sub>2</sub> and NO<sub>2</sub>,ect., and/or when load current is ow,and/or the PCB boards need to be washed after relays are soldered.
- 8) Regarding the plastic sealed relay, we should leave it cooling naturally untill below 40°C after welding, then clean it and deal with coating, remarkably the temperature of solvents should also be controlled below 40°C.Please avoid cleaning the relay by ultrasonic, avoid using the solvents like gasoline, Freon, and so on, which would affect the configuration of relay or influence the environment.
- 9) When applied with continuous current, the heat from relay coil will age its isolation. Thus, please do not ground connected the coil to reduce electrical errosion if possible. And please provide protection circuit to avoid broken wire and losses.
- 10) Please make sure that there are no silicon-based substances (such as silicon rubber, silicone oil, silicon-based coating agents, silicon fillers, etc.) around the relay, because it will generate silicon-containing volatile gas, which may cause poor contact in case of silicon-containing volatile gas sticking on contact.
- 11) About preferable condition of operation, storage and transportation, please refer to "Explanation to terminology and guidetines of relay".
- 12) During the relay pick-up or drop-out processes, there are stages of contact pressure change, contact vibration and unstable contact etc. When the voltage applied to coil is gradually changed, it will lengthen the unstable stage and affect relay endurance. To reduce this influence, please apply step voltage(switching circuit) to relay coil.

**Disclaimer**

The specification is for reference only. See to "Terminology and Guidelines" for more information. Specifications subject to change without notice. We could not evaluate all the performance and all the parameters for every possible application. Thus the user should be in a right position to choose the suitable product for their own application. If there is any query, please contact Hongfa for the technical service. However, it is the user's responsibility to determine which product should be used only.

© Xiamen Hongfa Electroacoustic Co., Ltd. All rights of Hongfa are reserved.