

HF116F-3

MINIATURE HIGH POWER RELAY



File No.:E134517



File No.:R 50154722



File No.:CQC18002206328



Features

- 30A switching capability
- 4kV dielectric strength (between coil and contacts)
- 3mm contact gap available

RoHS compliant

CONTACT DATA

Contact arrangement	1A	2A
Contact resistance ¹⁾	100mΩ max.(at 1A 24VDC)	
Contact material	AgSnO ₂ , AgCdO	
Contact rating (Res. load)	30A 240VAC 30A 277VAC	25A 240VAC 25A 277VAC
Max. switching voltage	277VAC	
Max. switching current	30A	25A
Max. switching power	8310VA	6925VA
Mechanical endurance	1 x 10 ⁷ OPS	
Electrical endurance	1H, 1HT type: 1 x 10 ⁵ OPS (30A 240VAC, Resistive load, Room temp., 1s on 9s off) 2H, 2HT type: 1 x 10 ⁵ OPS (25A 240VAC, Resistive load, Room temp., 1s on 9s off)	

Notes: 1) The data shown above are initial values.

CHARACTERISTICS

Insulation resistance	1000MΩ (at 500VDC)	
Dielectric strength	Between coil & contacts	4000VAC 1min
	Between open contacts	2000VAC 1min
Operate time (at nomi. volt.)	30ms max.(DC type)	
Release time (at nomi. volt.)	30ms max.(DC type)	
Shock resistance	Functional	Standard:98m/s ² Pulse width 11ms W type:98m/s ² Pulse width 6ms
	Destructive	980m/s ² Pulse width 6ms
Vibration resistance	Standard:10H to 55Hz 1.5mm DA W type:10H to 55Hz 1.0mm DA	
Ambient temperature	-55°C to 70°C	
Humidity	5% to 85% RH	
Termination	PCB, QC, Screw	
Unit weight	Approx. 120g	
Construction	Dust protected	

Notes: 1) The data shown above are initial values.

- 2) Please find coil temperature curve in the characteristic curves below.
3) UL insulation system: Class F, Class B.

COIL

Coil power	DC type: Approx. 1.9W; AC type: Approx. 2.7VA
------------	--------------------------------------------------

COIL DATA

at 23°C

Nominal Voltage VDC	Pick-up Voltage VDC max ¹⁾	Drop-out Voltage VDC min ¹⁾	Max. Voltage VDC * ²⁾	Coil Resistance Ω
3	2.25	0.3	3.3	4.7 x (1±10%)
6	4.50	0.6	6.6	18.8 x (1±10%)
12	9.00	1.2	13.2	75 x (1±10%)
24	18.0	2.4	26.4	300 x (1±10%)
48	36.0	4.8	52.8	1200 x (1±10%)
100	75.0	10.0	110	5200 x (1±10%)
110	82.5	11.0	121	6300 x (1±10%)
200	150	20.0	220	21000 x (1±10%)

Nominal Voltage VAC	Pick-up Voltage VAC max. ¹⁾	Drop-out Voltage VAC min. ¹⁾	Max. Voltage VAC * ²⁾	Coil Resistance Ω
6	4.80	0.90	6.6	18.8 x (1±10%)
12	9.60	1.80	13.2	75 x (1±10%)
24	19.2	3.60	26.4	300 x (1±10%)
48	38.4	7.20	52.8	1200 x (1±10%)
120	96.0	18.0	132	5200 x (1±10%)
220/240	176	33.0	242	20800 x (1±10%)

Notes: 1) The data shown above are initial values.

- 2)* Maximum voltage refers to the maximum voltage which relay coil could endure in a short period of time.

SAFETY APPROVAL RATINGS

UL/CUL	AgSnO ₂	30A 277VAC 85°C 1.5HP 120VAC 3HP 240VAC 85°C 10A 120VAC Tungsten 240VAC(FLA=20.5)(LRA=105) 85°C 25A Making 400VDC Breaking 60VDC 85°C
	AgCdO	30A 277VAC 1.5HP 120VAC 3HP 240VAC 10A 120VAC Tungsten TV-10 120VAC
TÜV		27A 240VAC COSØ =0.8 25A 240VAC COSØ =0.4 25A 240VAC COSØ =1

Notes: 1) All values unspecified are at room temperature.

- 2) Only typical loads are listed above. Other load specifications can be available upon request.



HONGFA RELAY

ISO9001, IATF16949, ISO14001, ISO45001, IECQ QC 080000, ISO/IEC 27001 CERTIFIED

2025 Rev. 1.00

ORDERING INFORMATION

Type		HF116F-3 / 012 D F -1H T F W C (XXX)	
Coil voltage	DC: 3VDC to 200VDC AC: 6VAC to 240VAC		
Coil voltage form	D: DC	A: AC	
Mouting	A: Mount	F: Flanged	
Contact arrangement	1H: 1 Form A	2H: 2 Form A ³⁾	
Contact material	T: AgSnO ₂	Nil: AgCdO	
Insulation standard	F: Class F	Nil: Class B	
Contact Gap	W: 3.0mm	Nil: Standard	
Capacitor	C: With Capacitor(Only for AC)	Nil: Without Capacitor	
Special code ⁴⁾	XXX: Customer special requirement	Nil: Standard	

Notes: 1) Water cleaning or surface process is not suggested after the dust-protected relays are assembled on PCB.

2) Dust-protected relays can not be used in the environment with pollutants like H₂S, SO₂, NO₂, dust, etc.

3) The standard product with 2H contact configuration is only applicable to circuits a and g specified in Table 16 of IEC 61810-1:2015. For applications in other circuits, please contact our company.

4) The customer special requirement express as special code after evaluating by Hongfa.

OUTLINE DIMENSIONS, WIRING DIAGRAM AND PC BOARD LAYOUT

Unit: mm

Outline Dimensions

HF116F-3/□□□□-F-1H

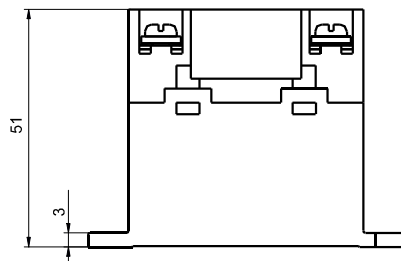

HF116F-3/□□□□-F-2H

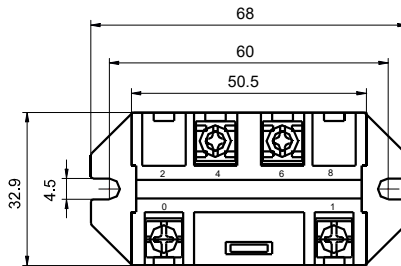
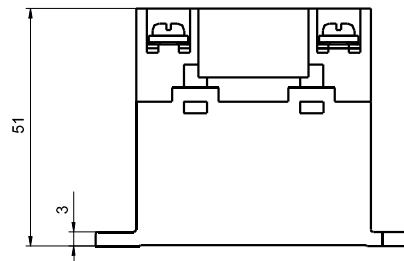

(Bottom view)

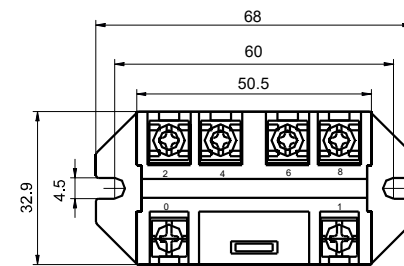

(Bottom view)

Outline Dimensions

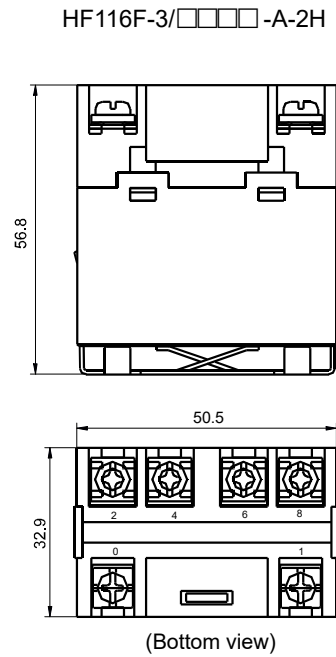
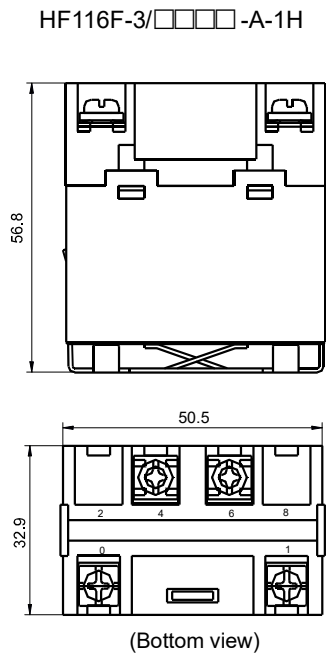

Remark: In case of no tolerance shown in outline dimension: outline dimension $\leq 1\text{mm}$, tolerance should be $\pm 0.2\text{mm}$; outline dimension $> 1\text{mm}$ and $\leq 5\text{mm}$, tolerance should be $\pm 0.3\text{mm}$; outline dimension $> 5\text{mm}$, tolerance should be $\pm 0.4\text{mm}$.

Wiring Diagram
(Bottom view)

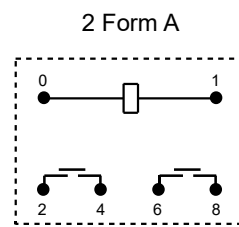
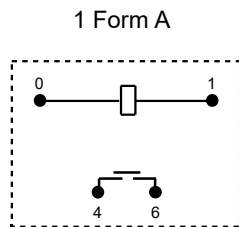

Coil Inner Circuit

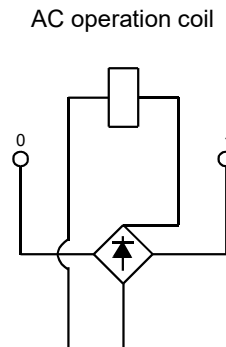
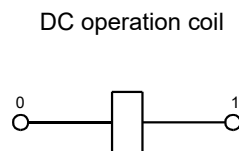

CHARACTERISTIC CURVES

MAXIMUM SWITCHING POWER

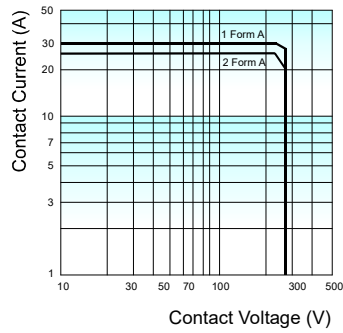

ENDURANCE CURVE

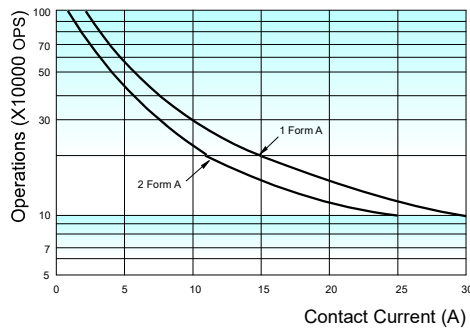

COIL TEMPERATURE RISE

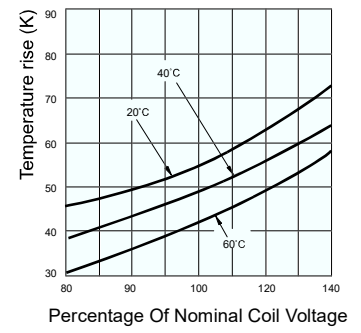

Test conditions:
250VAC, Resistive load,
Room temp., 1s on 9s off

Disclaimer

The specification is for reference only. See to "Terminology and Guidelines" for more information. Specifications subject to change without notice. We could not evaluate all the performance and all the parameters for every possible application. Thus the user should be in a right position to choose the suitable product for their own application. If there is any query, please contact Hongfa for the technical service. However, it is the user's responsibility to determine which product should be used only.

© Xiamen Hongfa Electroacoustic Co., Ltd. All rights of Hongfa are reserved.