

HFD43

1GHz SUBMINIATURE HIGH-FREQUENCY RELAY



Features

- Excellent high-frequency characteristics at 1GHz:
Insertion loss $\leq 0.2\text{dB}$,
Isolation: between open contacts $\geq 20\text{dB}$,
between contact sets $\geq 30\text{dB}$
- High temperature resistant products at 105°C are available
Products with mechanical endurance $\geq 1 \times 10^8$ ops available
- 2 Form C configuration
- Single-side stable and latching types available
- SMT type available
- Small product size

RoHS compliant

CONTACT DATA

Contact arrangement	2C	
Contact resistance ⁽¹⁾	100mΩ max. (at 10mA 30mVDC)	
Contact material	Silver alloy + Au plated	
Contact rating	Resistive load	1A 30VDC 0.3A 125VAC
	High frequency load	1W 1GHz
Max. switching voltage	125VAC / 30VDC	
Max. switching current	1A (30VDC)	
Max. switching power	37.5VA / 30W / 1W 1GHz	
Min. applicable load ⁽²⁾	10mV 10μA	
Mechanical endurance	5 x 10 ⁷ ops	
Electrical endurance ⁽³⁾	Resistive load	1 x 10 ⁵ ops(1A 30VDC, at 85°C, 1s on 9s off) 1 x 10 ⁵ ops (0.3A 125VAC, at 85°C, 1s on 9s off)
	High frequency load ⁽⁴⁾	1 x 10 ⁵ ops(1W 1GHz , at 85°C, 1s on 9s off)

- Notes:** 1) The data shown above are initial values.
2) Min. applicable load is reference value. Please perform the confirmation test with the actual load before production since reference value may change according to switching frequencies, environmental conditions and expected contact resistance and reliability.
3) The electrical endurance of resistive load is from the tests of one set of open contacts or one sets of close contacts.
4) These values are for a V.SWR of 1.2 max. at the load.

COIL

Coil power	Single-side stable	See "COIL DATA"
	1 coil latching	See "COIL DATA"
Temperature rise	50K max. (1A load, ambient temperature 85°C)	

HIGH-FREQUENCY CHARACTERISTICS

Frequency	1GHz	
Isolation	between open contacts	$\geq 20\text{dB}$
	between contact sets	$\geq 30\text{dB}$
Insertion loss	$\leq 0.2\text{dB}$	
V.SWR	≤ 1.2	
Through maximum power	3W ⁴⁾	

- Notes:** 1) The characteristic impedance of the measuring system is 50Ω .
2) The data shown above are initial values.
3) Please contact us if the relay will be used in an application that requires high repeatability in high-frequency characteristics for the microload area (such as test and measurement equipment and ATE, etc.)
4) These values are for a V.SWR of 1.2 max. at the load.

CHARACTERISTICS

Insulation resistance	1000MΩ (500VDC)	
Dielectric strength	Between coil & contacts	750VAC 1min
	Between open contacts	750VAC 1min
	Between contact sets	750VAC 1min
	Between coil, contact and grounding	500VAC 1min
Operate time (Set time)	$\leq 3\text{ms}$	
Release time (Reset time)	$\leq 3\text{ms}$	
Ambient temperature	-40°C to 85°C , -40°C to 105°C ²⁾	
Humidity	5% to 85% RH	
Vibration resistance	Functional	10Hz to 55Hz 3.3mm DA
	Destructive	10Hz to 55Hz 5.0mm DA
Shock resistance	Functional	735m/s ²
	Destructive	980m/s ²
Termination	SMT	
Unit weight	Approx 1.2g	
Moisture sensitivity levels (Only for SMT type, JEDEC-STD-020)	MSL3	
Construction	Plastic sealed	

- Notes:** 1) The data shown above are initial values.
2) The 888 version is for applications at 105°C .



HONGFA RELAY

ISO9001, IATF16949, ISO14001, ISO45001, IECQ QC 080000, ISO/IEC 27001 CERTIFIED

2026 Rev. 1.00

COIL DATA

at 23°C

Single side stable

Coil Code	Nominal Voltage VDC	Initial Pick-up Voltage VDC max.	Initial Drop-out Voltage VDC min.	Coil Resistance Ω	Nominal Power mW approx.	Max.(1) Voltage VDC
HFD43/1.5	1.5	1.13	0.15	16 x (1±10%)	140	2.2
HFD43/2.4	2.4	1.8	0.24	41 x (1±10%)	140	3.6
HFD43/3	3	2.25	0.3	64.3 x (1±10%)	140	4.5
HFD43/4.5	4.5	3.38	0.45	145 x (1±10%)	140	6.7
HFD43/5	5	3.75	0.5	178 x (1±10%)	140	7.5
HFD43/6	6	4.5	0.6	257 x (1±10%)	140	9.0
HFD43/9	9	6.75	0.9	579 x (1±10%)	140	13.5
HFD43/12	12	9	1.2	1028 x (1±10%)	140	18.0
HFD43/24	24	18	2.4	2880 x (1±10%)	200	36.0

1 coil latching

Coil Code	Nominal Voltage VDC	Initial Set Voltage VDC max.	Initial Reset Voltage VDC max.	Coil Resistance Ω	Nominal Power mW approx.	Max.(1) Voltage VDC
HFD43/1.5-L	1.5	1.13	1.13	22.5 x (1±10%)	100	3.0
HFD43/2.4-L	2.4	1.8	1.8	57.6x (1±10%)	100	4.8
HFD43/3-L	3	2.25	2.25	90 x (1±10%)	100	6.0
HFD43/4.5-L	4.5	3.38	3.38	202.5 x (1±10%)	100	9.0
HFD43/5-L	5	3.75	3.75	250 x (1±10%)	100	10.0
HFD43/6-L	6	4.5	4.5	360 x (1±10%)	100	12.0
HFD43/9-L	9	6.75	6.75	810 x (1±10%)	100	18.0
HFD43/12-L	12	9	9	1440 x (1±10%)	100	24.0
HFD43/24-L	24	18	18	2880 x (1±10%)	200	36.0

Notes:1) The data shown above are initial values.

2) To supply rated step voltage to coil is the foundation of relay proper operation. Please make sure the applied voltage to the coil reach at rated values.

Please refer to the typical diagram below for single side stable relay. The "V_coil" is the rated voltage:

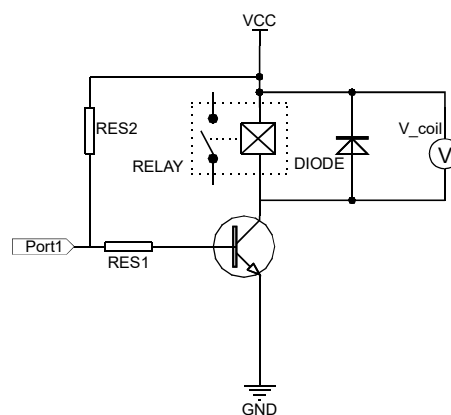

3) In case 5V of transistor drive circuit, it is recommended to use 4.5V type relay, and 3V to use 2.4V type relay.

4) For monostable relays, if you need to drop down voltage and hold mode after reliably operating, make sure that the effective value of holding voltage is not less than 60% of the rated voltage.

5) Maximum voltage refers to the maximum voltage which relay coil could endure in a short period of time.

6) When user's requirements can't be found in the above table, special order allowed.

7) During the relay pick-up or drop-out processes, there are stages of contact pressure change, contact vibration and unstable contact etc. When the voltage applied to coil is gradually changed, it will lengthen the unstable stage and affect relay endurance. To reduce this influence, please apply step voltage (switching circuit) to relay coil.

ORDERING INFORMATION

Type	HFD43 /		24	-L	S	R	(XXX)
Coil voltage	1.5, 2.4, 3, 4.5, 5, 6, 9, 12, 24VDC						
Sort	L: 1 coil latching		Nil: Single side stable				
Terminal type	S: Standard SMT		S1: Short terminal SMT				
Packing style	R: Tape and reel packing						
Special code ²⁾	XXX: Customer special requirement		Nil: Standard				
	For instance: Product with 888 suffix is for application at 105°C; (AJ6) indicates products with mechanical endurance $\geq 1 \times 10^8$ ops.						

- Notes:**
- 1) R type (tape and reel) packing is moisture-proof which meets requirement of MSL-3. For R type, the letter "R" will only be printed on packing tag but not on relay cover.
 - 2) Customer's special requirements will be identified by special codes after evaluation.
 - 3) A hyphen mark "-" should be added between coil voltage and sort/terminal type/packing style if any, for example: HFD43/24-SR.
 - 4) Relays of solder flux resistant type and dust cover type are not applicable in environments with moisture vapor and harmful gases such as phosphorus, chlorine, H₂S, SO₂ and NO₂; plastic-sealed relays shall be used instead with actual application tests for confirmation.
 - 5) Please make sure that there are no silicon-based substances (such as silicon rubber, silicone oil, silicon-based coating agents, silicon fillers, etc.) around the relay, because it will generate silicon-containing volatile gas, which may cause poor contact in case of silicon-containing volatile gas sticking on contact. Flux proofed and dust cover type relays are prohibited in environments with water vapor and harmful gases (P, Cl, H₂S, SO₂, NO₂). Plastic sealed relays shall be used with practical test verification.

OUTLINE DIMENSIONS, WIRING DIAGRAM AND PC BOARD LAYOUT

Unit: mm

Standard SMT type

Outline Dimensions

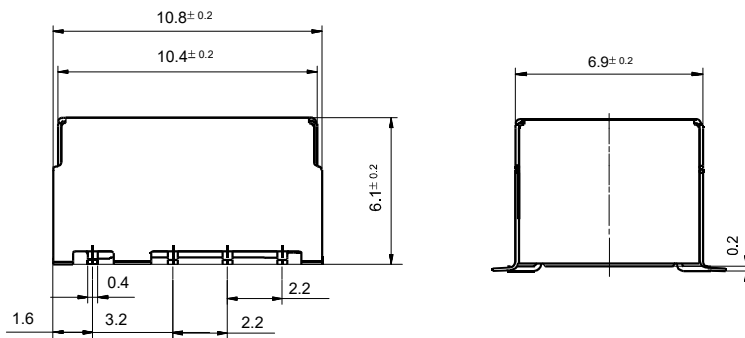

PCB Layout
(Bottom view)

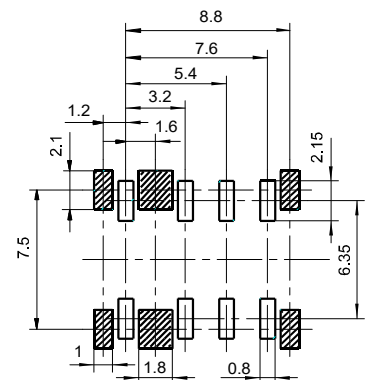
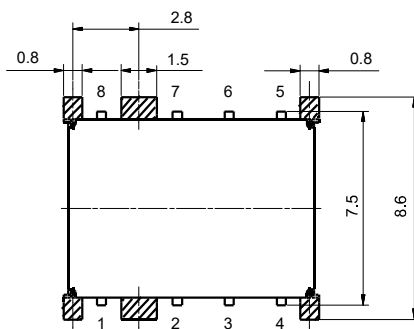

Remark: 1)  represents the ground terminal or ground mounting hole.

OUTLINE DIMENSIONS, WIRING DIAGRAM AND PC BOARD LAYOUT

Unit: mm

Wiring Diagram (Bottom view)

Single side stable(Bottom view)

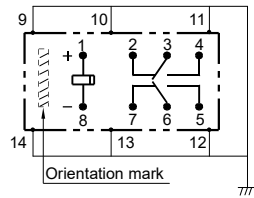

No energized condition

1 coil latching(Bottom view)

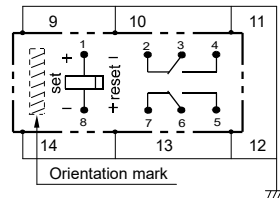

Reset condition

- Remark: 1) In case of no tolerance shown in outline dimension: outline dimension $\leq 1\text{mm}$, tolerance should be $\pm 0.2\text{mm}$; outline dimension $> 1\text{mm}$ and $\leq 5\text{mm}$, tolerance should be $\pm 0.3\text{mm}$; outline dimension $> 5\text{mm}$, tolerance should be $\pm 0.4\text{mm}$.
 2) The tolerance without indicating for PCB layout is always $\pm 0.1\text{mm}$.
 3) 9~14 is ground terminal.

Short terminalSMT type

Outline Dimensions

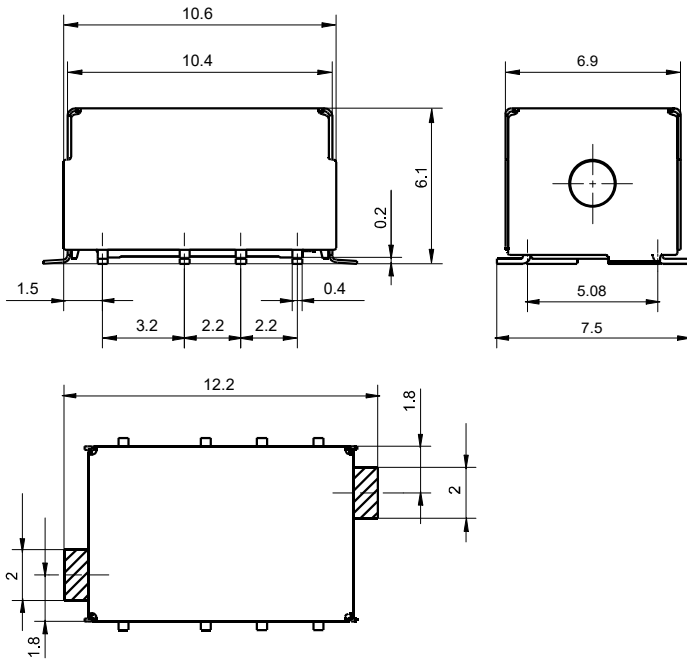

PCB Layout (Bottom view)

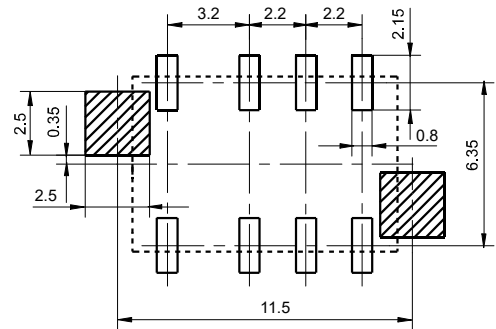

Remark: 1) represents the ground terminal or ground mounting hole.

Wiring Diagram

Single side stable(Bottom view)

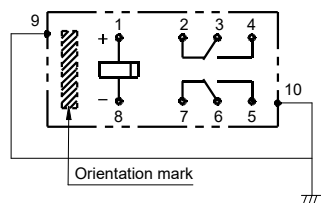

No energized condition

1 coil latching(Bottom view)

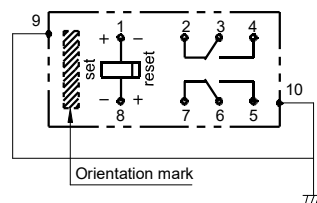

Reset condition

OUTLINE DIMENSIONS, WIRING DIAGRAM AND PC BOARD LAYOUT

Unit: mm

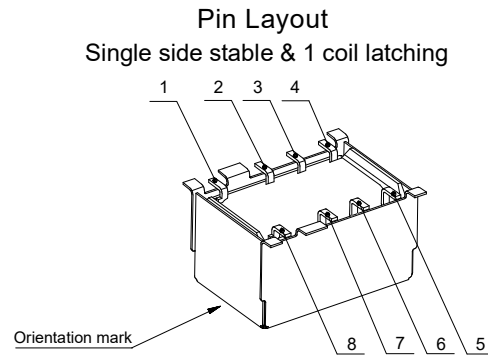

- Remark: 1) In case of no tolerance shown in outline dimension: outline dimension $\leq 1\text{mm}$, tolerance should be $\pm 0.2\text{mm}$; outline dimension $> 1\text{mm}$ and $\leq 5\text{mm}$, tolerance should be $\pm 0.3\text{mm}$; outline dimension $> 5\text{mm}$, tolerance should be $\pm 0.4\text{mm}$.
 2) The tolerance without indicating for PCB layout is always $\pm 0.1\text{mm}$.
 3) 9~10 is ground terminal.

TAPE PACKING

Unit: mm

Direction of Relay Insertion

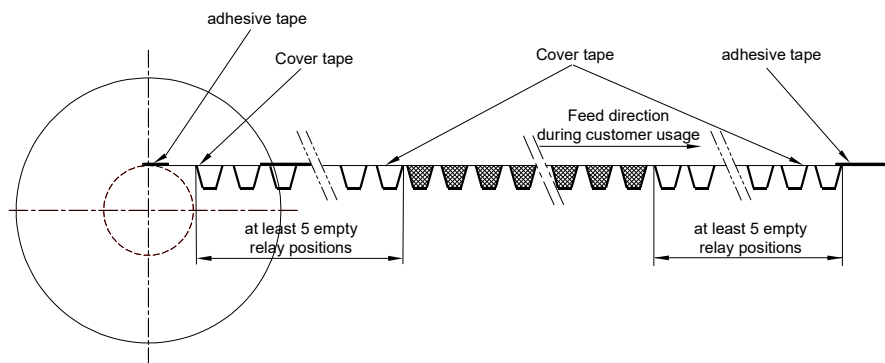
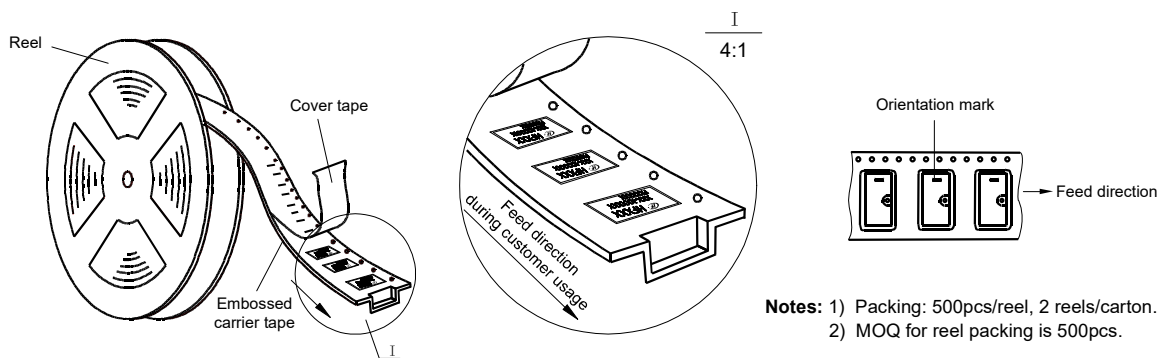

Reel Dimensions

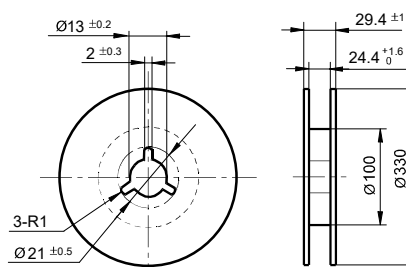

TAPE PACKING

Unit: mm

Tape Dimensions (S type: Standard SMT)

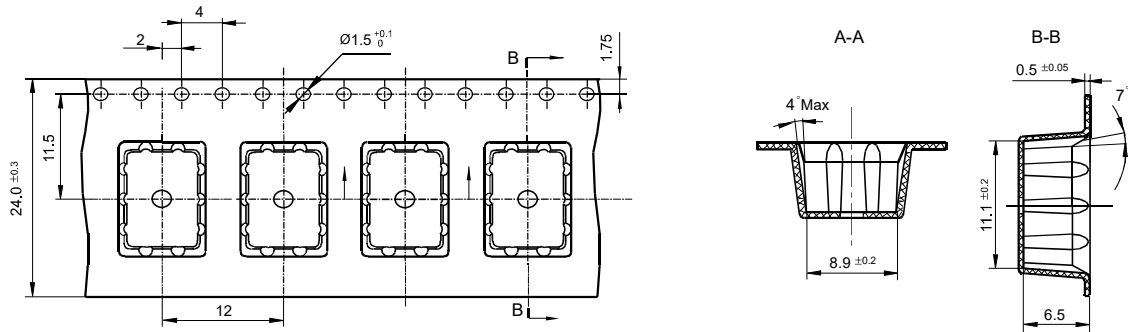

Tape Dimensions (S1 type: Short terminal SMT)

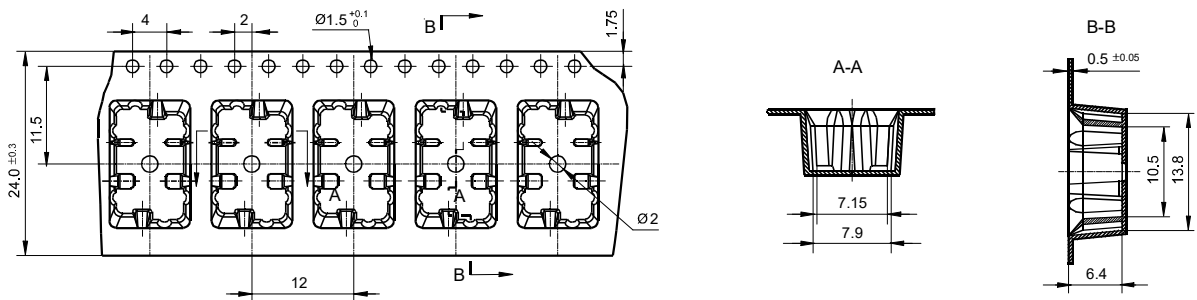

HIGH FREQUENCY CHARACTERISTICS CURVES

Isolation (between open contacts)

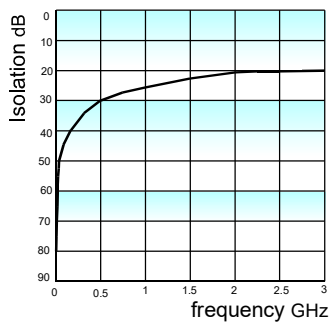

Insertion loss

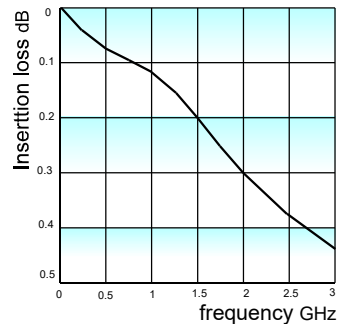

Voltage standing wave ratio

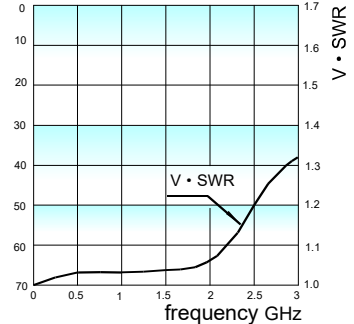

- Remark: (1) Ambient temperature conditions is 23°C.
 (2) The data shown above are initial values.
 (3) The high-frequency characteristics will vary depending on the PCB board. Please be sure to check performance parameters including durability in actual equipment before use.
 (4) Test model and specification: HFD43/5-SR, test instrument: Keysight E5071C network analyzer, the characteristic impedance of the measurement system is 50 Ω.

CHARACTERISTIC CURVES

MAXIMUM SWITCHING POWER

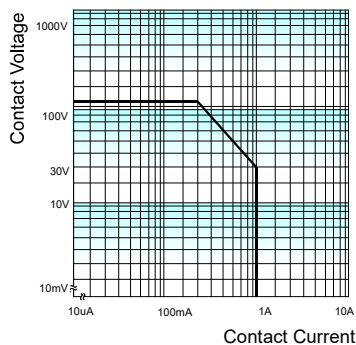

ENDURANCE CURVE

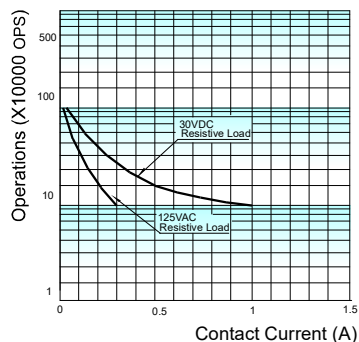

REFLOW SOLDERING, TEMPERATURE ON PCB BOARD
RECOMMENDED SOLDERING TEMPERATURE

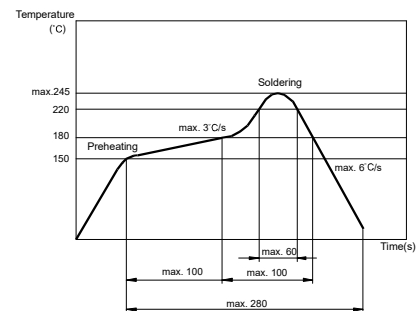

Test conditions:

Resistive load, 1s on 9s off.

Notice

- 1) This relay is highly sensitive polarized relay, if correct polarity is not applied to the coil terminals, the relay does not operate properly.
- 2) To avoid using relays under strong magnetic field which will change the parameters of relays such as pick-up voltage and drop-out voltage.
- 3) Relay is on the "reset" status when being released from stock, with the consideration of shock risen from transit and relay mounting, it should be changed to the "set" status when application(connecting to the power supply). Please reset the relay to "set" or "reset" status on request.
- 4) Energizing coil with rated voltage is basic for normal operation of a relay, please make sure the energized voltage to relay coil have reached the rated voltage. Regarding latching relay, in order to maintain the "set" or "reset" status, impulse width of the rated voltage applied to coil should be more than 5 times of "set" or "reset" time.
- 5) For a monosteady state relay, after the relay is reliably operated, if it needs to be kept under pressure, make sure that the effective value of the voltage is not less than 60% of the rated voltage;
- 6) The relay may be damaged because of falling or when shocking conditions exceed the requirement.
- 7) For SMT products, validation with real application should be done before your series production, if the reflow-soldering temperature curve is out of our recommendation. Generally, two-time reflow-soldering is not recommended for the relay. However, if two-time reflow-soldering is required, a 60-min. interval should be guaranteed and a validation should be done before production.
- 8) Contact is recommended for suitable condition and specifications if water cleaning or surface process is involved in assembling relays on PCB.
- 9) Regarding the plastic sealed relay, we should leave it cooling naturally until below 40°C after welding, then clean it and deal with coating, remarkably the temperature of solvents should also be controlled below 40°C. Please avoid cleaning the relay by ultrasonic, avoid using the solvents like gasoline, Freon, and so on, which would affect the configuration of relay or influence the environment.
- 10) About preferable condition of operation, storage and transportation, please refer to "Explanation to terminology and guidelines of relay".
- 11) Relays packaged in moisture barrier bags meet MSL-3 requirements. The relays should be stored at ambient conditions of $\leq 30^{\circ}\text{C}$ and $\leq 60\%$ RH after they are removed from their packaging, and should be used within 168 hours. If the relays cannot be used within 168 hours, please repack them or store them in a drying oven at $25^{\circ}\text{C} \pm 5^{\circ}\text{C}$, $\leq 10\%$ RH. Otherwise, relays may be subjected to a soldering test to check their performance, or they may be used after keeping them in an oven for 72 hours at with $50^{\circ}\text{C} \pm 5^{\circ}\text{C}$, $\leq 30\%$ RH.
- 12) Do not use one relay for both heavy?load and light/RF?load switching, as contact spatter will cause failure or poor RF performance/
- 13) When applied with continuous current, the heat from relay coil will age its isolation. Thus, please do not ground connected the coil to reduce electrical erosion if possible. And please provide protection circuit to avoid broken wire and losses.
- 14) Please make sure that there are no silicon-based substances (such as silicon rubber, silicone oil, silicon-based coating agents, silicon fillers,etc.) around the relay, because it will generate silicon-containing volatile gas, which may cause poor contact in case of silicon-containing volatile gas sticking on contact. Flux proofed and dust cover type relays are prohibited in environments with water vapor and harmful gases (P, Cl, H₂S, SO₂, NO₂). Plastic sealed relays shall be used with practical test verification.
- 15) For other usage, storage and transportation requirements, please refer to Relay Terminology and Selection Guide.
- 16) During the relay pick-up or drop-out processes, there are stages of contact pressure change, contact vibration and unstable contact etc. When the voltage applied to coil is gradually changed, it will lengthen the unstable stage and affect relay endurance. To reduce this influence, please apply step voltage (switching circuit) to relay coil.

Disclaimer

The specification is for reference only. See to "Terminology and Guidelines" for more information. Specifications subject to change without notice. We could not evaluate all the performance and all the parameters for every possible application. Thus the user should be in a right position to choose the suitable product for their own application. If there is any query, please contact Hongfa for the technical service. However, it is the user's responsibility to determine which product should be used only.

© Xiamen Hongfa Electroacoustic Co., Ltd. All rights of Hongfa are reserved.