

HFV16

AUTOMOTIVE RELAY

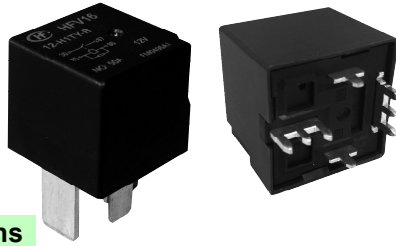

Typical Applications

Fog lamp & headlight control, Rear window defogger, Air-conditioning, Fuel pump control, ABS, Traction control system, Cooling fan control, Battery disconnection device, High-speed fan control

Features

- 70A switching capability
- Extended temp. range up to 125°C
- Transient suppression resistor or diode available
- 1 Form A contact arrangement
- Plastic sealed and dust protected types available
- QC terminal and PCB terminal available
- RoHS & ELV compliant
- Pin assignment similar to ISO 7588-1

CHARACTERISTICS

Contact arrangement	1A	Shock resistance ^{5) 10)}	294m/s ²
Voltage drop	Typ.: 20mV (at 10A)	Flammability ⁶⁾	UL94-HB or better (meets FMVSS 302)
	Max.: 250mV (at 10A)	Termination	QC ¹¹⁾ , PCB ⁷⁾
Max. continuous current ^{1) 10)}	70A (at 23°C), 50A(at 85°C),	Construction	Plastic sealed, Dust protected
	30A(at 125°C)	Unit weight	Approx. 38g
Max. switching current ¹⁰⁾	Make (NO): 200A ²⁾	Mechanical data ⁸⁾	housing retention (pull & push): 200N min.
	Break (NO):70A (Resistive, 13.5VDC)		terminal retention (pull & push): 100N min.
Min. contact load	1A 12VDC		terminal resistance to bending (front & side): 10N min. ⁹⁾
Electrical endurance	See "CONTACT DATA"		
Mechanical endurance	1 x 10 ⁶ OPS (300OPS/min)		
insulation resistance	100MΩ (at 500VDC)		
Withstand voltage ³⁾	500VAC		
Operate time ¹⁰⁾	Max.: 10ms (at nomi. vol.)		
Release time ^{4) 10)}	Max.: 10ms		
Ambient temperature	-40°C to 125°C		
Vibration resistance ^{5) 10)}	5Hz to 22.3Hz 10mm DA		
	22.3Hz to 500Hz 98m/s ²		

1) Measured when applying 100% rated voltage on coil.

2) Inrush peak current under lamp load, at 13.5VDC.

3) 1min, leakage current less than 1mA

4) The value is measured when voltage drops suddenly from nominal voltage to 0 VDC and coil is not paralleled with suppression circuit.

5) When energized, opening time of NO contacts shall not exceed 100μs.

6) FMVSS: Federal Motor Vehicle Safety Standard.

7) Since it is an environmental friendly product, please select lead-free solder when welding. The recommended soldering temperature and time is (260±3)°C , (5±0.3)s.

8) Only valid for QC version.

9) Test point is at 2mm away from terminal end, and after removing testing force, the terminal transfiguration shall not exceed 0.3mm.

10) Only for the 12VDC coil voltage type.

11) Do NOT knock on relays with hard objects such as rubber rod and rubber hammer during mounting, which might lead to relay damage.

CONTACT DATA ⁵⁾

Load voltage	Load type	Load current A	On/Off ratio		Electrical endurance ³⁾ OPS	Contact material	Load wiring diagram ⁴⁾	Ambient temp.	
			On s	Off s					
13.5VDC	Resistive	Make	70	2	2	1×10 ⁵	See diagram 1	at 23°C	
		Break	70						
	Inductive	Make	150	2	4	1×10 ⁵	See diagram 2	See Ambient temp. curve	
		Break	50						
	Lamp ¹⁾	Make	200 ²⁾	2	2	1×10 ⁵	See diagram 3		
		Break	40						
27VDC	Resistive	Make	40	2	2	1×10 ⁵	See diagram 1		at 23°C
		Break	40						



HONGFA RELAY

ISO9001, IATF16949, ISO14001, ISO45001, IECQ QC 080000, ISO/IEC 27001 CERTIFIED

2025 Rev. 1.00

- 1) The load in the table excludes flasher. When applied in flasher, a special silver alloy (AgSnO₂) contact material should be used and the customer special code should be (170) as a suffix. Please heed the anode and cathode's request when wired, terminal 30 should connect with anode.
- 2) Corresponds to the peak inrush current on initial actuation (cold filament).
- 3) A low resistive or diode suppression device in parallel to the relay coil increases the release time and reduces the life time caused by increased erosion and / or higher risk of contact welding.
- 4) The load wiring diagrams are listed below:

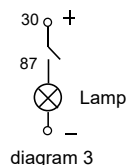
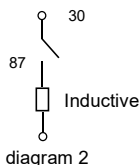
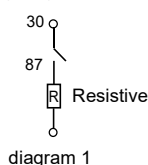

- 5) Loads mentioned in this chart is for relays with no parallel diode or Zener Diode. For those with parallel diode, Zener Diode or other components, please contact Hongfa for more technical supports.
Please also contact Hongfa if the actual application load is different from what mentioned above.

COIL DATA at 23°C

Nominal voltage VDC	Pick-up voltage VDC max.	Drop-out voltage VDC min.	Coil resistance x(1±10%)Ω	Parallel resistance x(1±5%)Ω	Equivalent resistance Ω	Power consumption W	Max. allowable overdrive voltage ¹⁾ VDC	
							at 23°C	at 85°C
12	7.2	1.2	90	—	—	1.6	20.2	15.7
12	7.2	1.2	90	680	79.5	1.8	20.2	15.7
24	16	2.4	320	—	—	1.8	40.5	31.5
24	16	2.4	320	2700	286	2.0	40.5	31.5

- 1) Max. allowable overdrive voltage is stated with no load applied.
- 2) Illustrated with the type with parallel resistor (680Ω, 12V), (2700Ω,24V).

ORDERING INFORMATION

	HFV16 / 12 -H 1 S T Y K -R (XXX)							
Type	HFV16: QC type HFV16-P: PCB type							
Coil voltage	12: 12VDC 24: 24VDC							
Contact arrangement	H: 1 Form A							
Version	1: QC Terminal Nil: PCB type 4: Plastic Bracket							
Construction ¹⁾	S: Plastic sealed ²⁾ Nil: Dust protected							
Contact material	T: AgSnO ₂							
Terminal	Y: QC Terminal without hole and 30 & 87 terminal length is 14.5mm Nil: QC Terminal with hole and 30 & 87 terminal length is 14.5mm, or PCB type							
Terminal plating code	K: Load terminal hot-dip Tinning, coil terminal electro-tinning Nil: Electro-tinning							
Parallel coil components ³⁾	R: Parallel transient suppression resistors(680Ω, 12V) (2700Ω,24V) R1: Parallel transient suppression resistors(560Ω, 12V) (1200Ω,24V) D: Parallel transient suppression diode, with anode connected to terminal#85 D1: Parallel transient suppression diode, with anode connected to terminal#86 Nil: Without parallel components							
Special code ⁴⁾	XXX: Customer special requirement Nil: Standard							

- Notes:** 1) In environments with high humidity, moisture, or even condensation, and dust, such as relays used in engineering, mining, agriculture and other fields, or relays with mounting brackets installed outside of electrical boxes, It is recommended to use plastic-encapsulated products; in environments containing phosphorus, H₂S, SO₂, NO₂ and other harmful gases, plastic-encapsulated types must be used and tested and confirmed in actual use; in environments containing organic silicon, please avoid using dust-proof covers ;
- 2) Contact is recommended for suitable condition and specifications if water cleaning or surface process is involved in assembling relays on PCB.
- 3) If the switch-off peak voltage of coil is required to be smaller than 100V, R1 shall be used (measured voltage of 12V is 13.5V); If parallel diode, Zener Diode or other components are required, please contact Hongfa for more technical supports.
- 4) The customer special requirement express as special code after evaluating by Hongfa. e.g. (170) stands for flasher load. The performance parameters of products with characteristic numbers shall be subject to the specific specifications provided by Hongfa.

OUTLINE DIMENSIONS AND WIRING DIAGRAM

Unit: mm

Outline Dimensions

HFV16/□□-H1T□-□□(XXX)

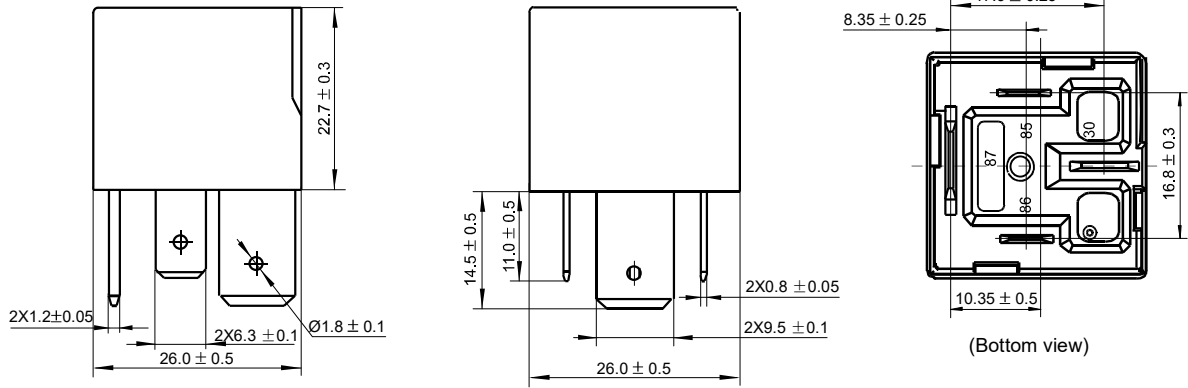

HFV16/□□-H1ST□-□□(XXX)

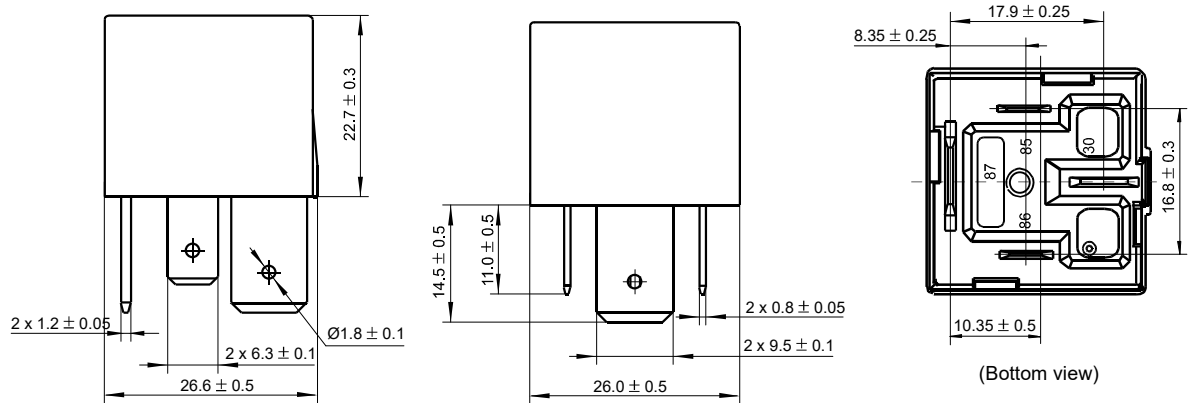

HFV16-P/□□-HT(XXX)

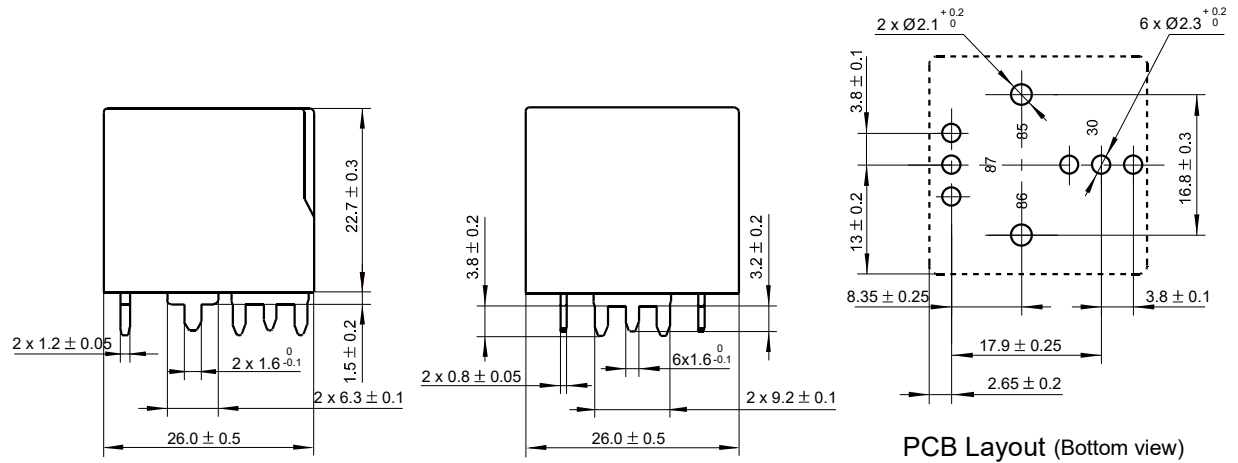

OUTLINE DIMENSIONS AND WIRING DIAGRAM

Unit: mm

Outline Dimensions

HFV16-P/□□-HST(XXX)

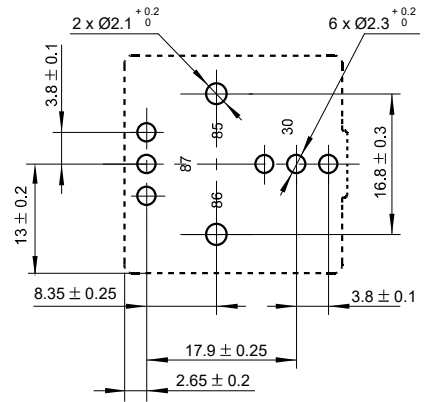
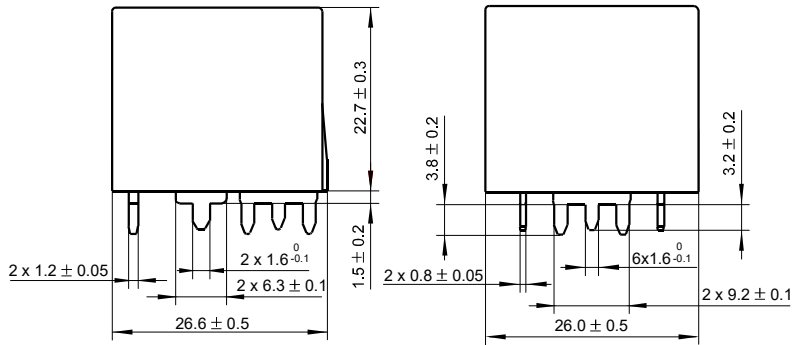

PCB Layout (Bottom view)

HFV16/□□-H4□□T□-□□(XXX)

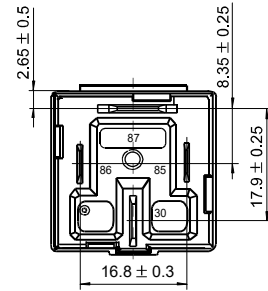
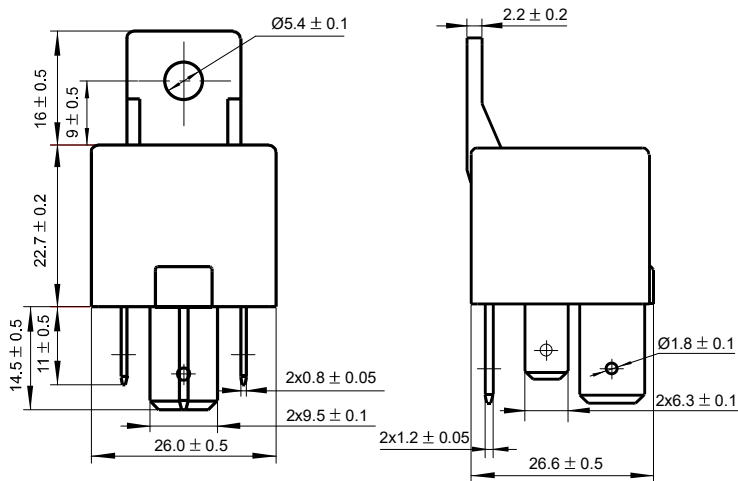

(Bottom view)

Remark: Terminal vertical deviation tolerance is 0.3mm.

Wiring Diagram

HFV16□□/□□-H□□T□(XXX)

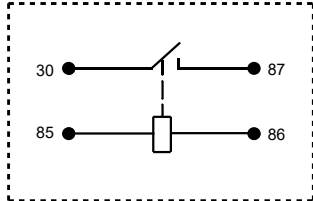

HFV16□□/□□-H□□T□-R(XXX)

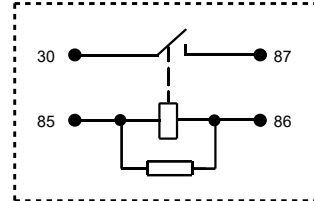

HFV16□□/□□-H□□T□-D(XXX)

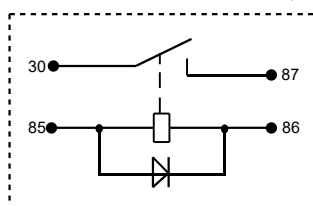

HFV16□□/□□-H□□T□-D1(XXX)

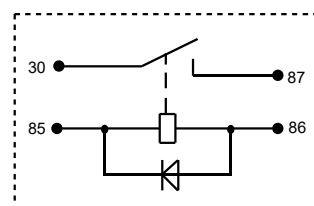

CHARACTERISTIC CURVES

1. Ambient temperature curve of the electrical endurance test

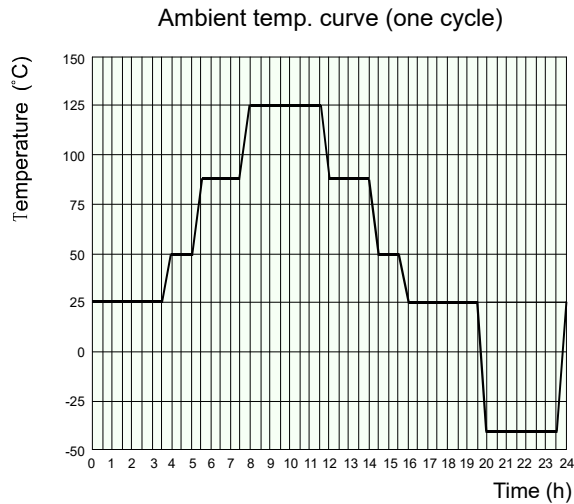

- 1) The minimum temperature is -40°C .
- 2) The maximum temperature is 125°C .

2. Load limit curve

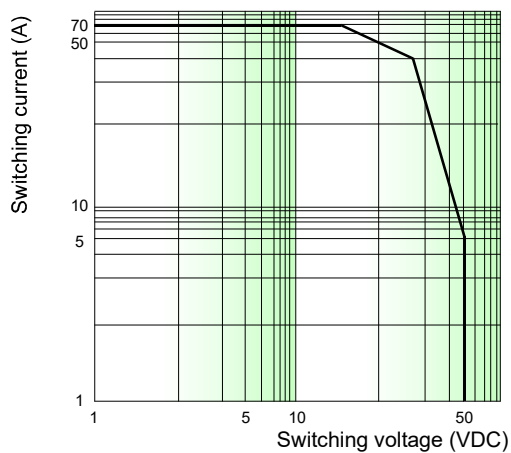

- 1) The contact load is resistive.
- 2) The load and electrical endurance tests are made according to "CONTACT DATA" parameters' table. If actual load voltage, current, or operate frequency is different from "CONTACT DATA" table, please arrange corresponding tests for confirmation.

Disclaimer

The specification is for reference only. See to "Terminology and Guidelines" for more information. Specifications subject to change without notice. In case there is specific criterion (such as mission profile, technical specification, PPAP etc.) checked and agreed by and between customer and Hongfa, this specific criterion should be taken as standard regarding any requirement on Hongfa product.

We could not evaluate all the performance and all the parameters for every possible application. Thus the user should be in a right position to choose the suitable product for their own application. If there is any query, please contact Hongfa for the technical service. However, it is the user's responsibility to determine which product should be used only.

© Xiamen Hongfa Electroacoustic Co., Ltd. All rights of Hongfa are reserved.