

HF KH

SUBMINIATURE AUTOMOTIVE RELAY

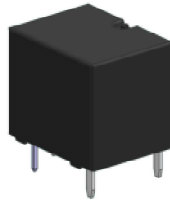

Typical Applications

Central door lock, Power doors & windows, Turning lamp control, Mirror adjustment, Seat adjustment, Speed-limit indicator control, Warm-up control, Wiper control

Features

- Tight structure and light weight
- High current contact capacity
(Carrying current: 35A/10min 25A/1h)
- Improved heat resistance
- RoHS & ELV compliant

CHARACTERISTICS

Contact arrangement	1A, 1C
Voltage drop (initial) ¹⁾	Typ.: 50mV (at 10A) Max.: 250mV (at 10A)
Max. continuous current ²⁾	35A (at 23°C, 10min) 25A (at 23°C, 1h)
Max. switching current ³⁾	NO: 35A NC: 20A
Max. switching voltage	16VDC
Min. contact load ⁴⁾	1A 12VDC
Electrical endurance	See "CONTACT DATA"
Mechanical endurance	1 x 10 ⁷ ops (300ops/min)
Initial insulation resistance	100MΩ (at 500VDC)
Withstand voltage ⁵⁾	500VAC
Operate time	Max.: 10ms (at nomi. vol.)
Release time ⁶⁾	Max.: 5ms
Ambient temperature	-40°C to 85°C
Vibration resistance ⁷⁾	10Hz to 55Hz 1.5mm DA
Shock resistance ⁷⁾	98m/s ²
Termination	PCB ⁸⁾

Construction	Plastic sealed
Unit weight	Approx. 6g

- Equivalent to the max. initial contact resistance is 100mΩ (at 1A 6VDC).
- Test under the following conditions:
 - The relay is mounted on the PCB, the coil is applied with 100% rated voltage;
 - The PCB board is a double layer board. The thickness of the copper foil is 4 oz (140μm), the width of each copper foil is 4.86x(1±5%)mm, the length of the copper foil is (50±1)mm, and the Tg value of the PCB board is 150°C;
 - The sample orders were only tested.
 - It varies by connection conditions. Additionally, reliable performance under repeated power-on cannot be guaranteed. Verify based on actual operating conditions during use.
- At 23°C, 13.5VDC (100 cycles, resistive load).
- Lower limit target for on-off operation at low load. This value varies by on-off frequency, environmental conditions and expected reliability level; verify with actual load during use.
- 1min, leakage current less than 1mA.
- The value is measured when voltage drops suddenly from nominal voltage to 0VDC and coil is not paralleled with suppression circuit.
- When energized, opening time of NO contacts shall not exceed 100μs, when non-energized, opening time of NC contacts shall not exceed 100μs, meantime, NO contacts shall not be closed.
- Since it is an environmental friendly product, please select lead-free solder when welding. The recommended soldering temperature and time is (260±3)°C, (5±0.5)s.

CONTACT DATA⁵⁾

at 23°C

Load voltage	Load type		Load current A			On/Off ratio		Electrical endurance OPS	Contact material	Load wiring diagram ⁴⁾
			1C		1A	On s	Off s			
			NO	NC						
13.5VDC	Resistive	Make	20	10	20	2	2	2×10 ⁵	AgSnO ₂	See diagram 1
		Break	20	10	20	2	2			
	Resistive	Make	30	—	30	2	2	1×10 ⁵	AgSnO ₂	See diagram 2
		Break	30	—	30					
	Motor Locked	Make	25 ³⁾	—	25 ³⁾	0.2	2	1×10 ⁵	AgSnO ₂	See diagram 3
		Break	25 ³⁾	—	25 ³⁾					



HONGFA RELAY

ISO9001, IATF16949, ISO14001, ISO45001, IECQ QC 080000, ISO/IEC 27001 CERTIFIED

2025 Rev. 2.00

CONTACT DATA ⁵⁾

at 23°C

Load voltage	Load type		Load current A			On/Off ratio		Electrical endurance OPS	Contact material	Load wiring diagram ⁴⁾
			1C		1A	On s	Off s			
			NO	NC						
13.5VDC	Lamp ¹⁾	Make	90 ²⁾	—	90 ²⁾	1	9	1×10 ⁵ (at 85°C)	AgSnO ₂	See diagram 3
		Break	8.8	—	8.8					
	Lamp ¹⁾	Make	6×21W	—	6×21W	1	6	1×10 ⁵	AgSnO ₂	See diagram 3
		Break								
	Flasher	Make	3×21W	—	3×21W	0.365	0.365	2×10 ⁶	Special AgSnO ₂	See diagram 4
		Break								

- Notes:** 1) When it is utilized in flasher, a special AgSnO₂ contact material should be used and the customer special code should be (170) as a suffix. Please connect by the polarity according to the diagram below.
 2) Corresponds to the peak inrush current on initial actuation (cold filament).
 3) Corresponds to the peak inrush current on initial actuation (motor).
 4) The load wiring diagrams are listed below (Ratings of NO, NC are tested based on different samples separately) :

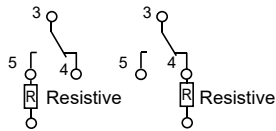

diagram 1

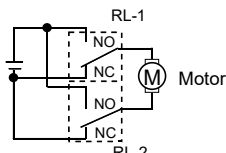

diagram 2

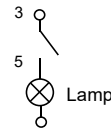

diagram 3

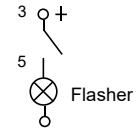

diagram 4

- 5) When the load voltage is at 24VDC or higher, or the applications conditions are different from the table above, please submit the detailed application conditions to Hongfa to get more support.

COIL DATA

Nominal voltage ¹⁾ VDC	Pick-up voltage VDC max.			Drop-out voltage VDC min.			Coil resistance x(±10%)Ω	Power consumption W
	23°C	85°C	125°C	23°C	85°C	125°C		
10	6.3	7.9	8.9	0.8	1.0	1.1	180	0.56
12	7.3	9.2	10.3	1.0	1.2	1.4	225	0.64

- Notes:** 1) Other types on request.

ORDERING INFORMATION

	HFKH /	12	-Z	S	-T	(XXX)
Type	HFKH: Standard					
Coil voltage	10: 10VDC		12: 12VDC			
Contact arrangement	H: 1 Form A		Z: 1 Form C			
Construction	S: Plastic sealed ¹⁾ Nil: Flux proofed					
Contact material	T: AgSnO ₂					
Special code²⁾	XXX: Customer special requirement			Nil: Standard		

- Notes:** 1) Contact us for suitable soldering conditions and product specifications if post-soldering cleaning or surface treatment is required after the relays are soldered onto the PCB.
 2) The performance parameters of products with characteristic numbers shall be subject to the specific specifications provided by Hongfa.
 3) The customer special requirement express as special code after evaluating by Hongfa. e.g. (170) stands for flasher load. The performance parameters of products with characteristic numbers shall be subject to the specific specifications provided by Hongfa.

OUTLINE DIMENSIONS, WIRING DIAGRAM AND PC BOARD LAYOUT

Unit: mm

Outline Dimensions(1 Form A / 1 Form C)

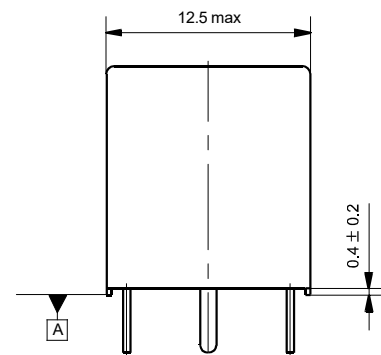
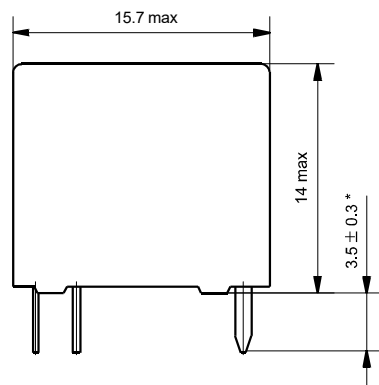
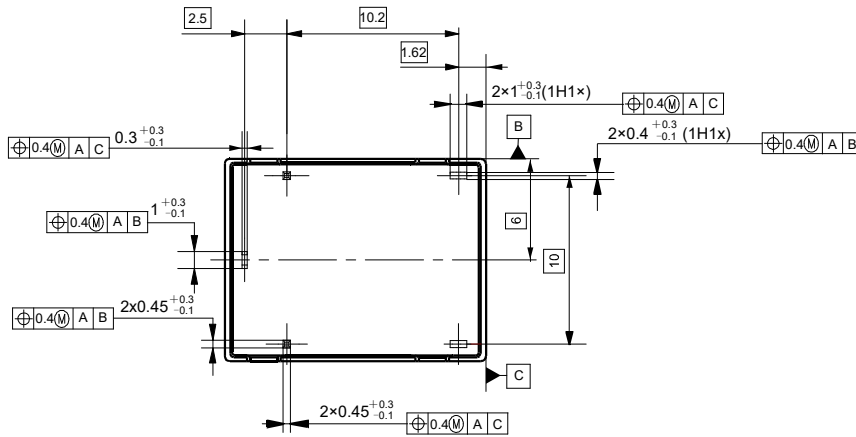

Remark: * The additional tin top is max. 1mm.

Wiring Diagram (Bottom view)

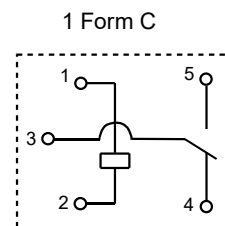
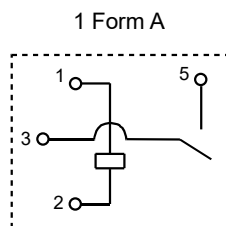

OUTLINE DIMENSIONS, WIRING DIAGRAM AND PC BOARD LAYOUT

Unit: mm

PCB Layout (Bottom view)

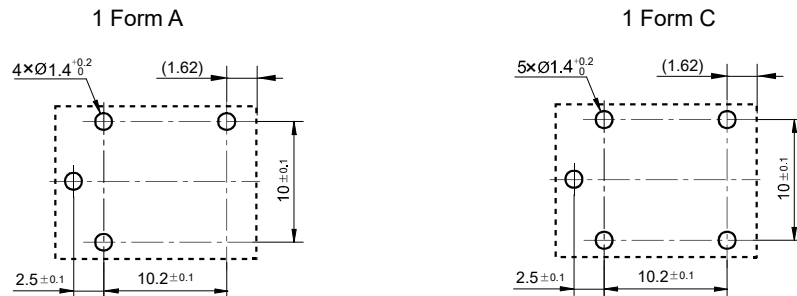

CHARACTERISTIC CURVES

1. Load curve (NO contacts, at 23°C)

Electrical endurance curve (Motor locked)

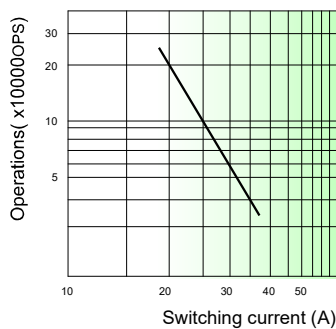

HFKH/12-ZST(XXX)

Test conditions: 0.2s ON, 2s OFF

Coil temperature rise

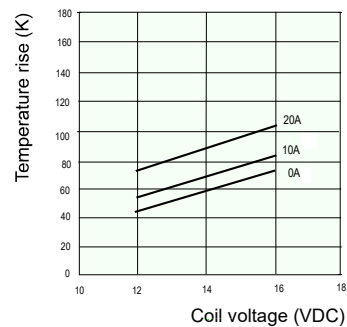

HFKH/12-ZST(XXX)

Notes: The coil temperature rise test requires the relay to be installed on the PCB board;
 The PCB board is a double layer board;
 The thickness of the copper foil is 4 oz (140µm), the width of each copper foil is 4.86x(1±5%)mm;
 The length of the copper foil is (50±1)mm, Installation spacing is 100mm.

Disclaimer

The specification is for reference only. See to "Terminology and Guidelines" for more information. Specifications subject to change without notice. In case there is specific criterion (such as mission profile, technical specification, PPAP etc.) checked and agreed by and between customer and Hongfa, this specific criterion should be taken as standard regarding any requirement on Hongfa product. We could not evaluate all the performance and all the parameters for every possible application. Thus the user should be in a right position to choose the suitable product for their own application. If there is any query, please contact Hongfa for the technical service. However, it is the user's responsibility to determine which product should be used only.

© Xiamen Hongfa Electroacoustic Co., Ltd. All rights of Hongfa are reserved.