

HFV7

AUTOMOTIVE RELAY

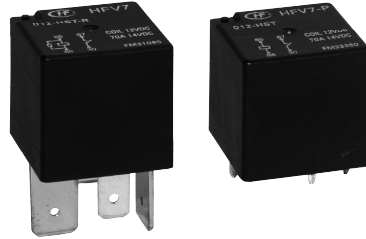

Typical Applications

Fog lamp & headlight control, Rear window defogger, Air-conditioning, Power distribution, Fuel pump control, ABS, Traction control system, Cooling fan control, Heating control, Power supply management system, Battery disconnection device

Features

- 70A switching capability
- Extended temp. range up to 125°C
- With transient suppression resistor available
- 1 Form A contact arrangement
- Plastic sealed and dust protected types available
- RoHS & ELV compliant

CHARACTERISTICS

Contact arrangement	1A
Voltage drop	Typ.: 20mV (at 10A) Max.: 250mV (at 10A)
Max. continuous current ^{1) 10)}	70A (at 23°C); 50A (at 85°C); 30A (125°C)
Max. switching current ¹⁰⁾	ON: 200A ²⁾ OFF: 70A(Resistive), 13.5VDC
Min. contact load	1A 12VDC
Electrical endurance	See "CONTACT DATA"
Mechanical endurance	1 x 10 ⁶ OPS (300OPS/min)
insulation resistance	100MΩ (at 500VDC)
Withstand voltage ³⁾	500VAC
Operate time ¹⁰⁾	Typ.: 6ms (at nomi. vol.) Max.: 10ms (at nomi. vol.)
Release time ^{4) 10)}	Typ.: 4ms Max.: 10ms
Ambient temperature	-40°C to 125°C
Vibration resistance ^{5) 10)}	10Hz to 55Hz 3.0mm DA 55Hz to 500Hz 100m/s ²

Shock resistance ^{5) 10)}	294m/s ²
Flammability ⁶⁾	UL94-HB or better (meets FMVSS 302)
Termination	QC ¹¹⁾ , PCB ⁷⁾
Construction	Plastic sealed, Dust protected
Unit weight	Standard: Approx. 38g
Mechanical data ⁸⁾	cover retention (pull & push): 200N min. terminal retention (pull & push): 100N min. terminal resistance to bending (front & side): 10N min. ⁹⁾

- 1) For 70A type(standard type), measured when applying 100% rated voltage on coil.
- 2) For 70A type(standard type), see "Load limit curv " for details.
- 3) 1min, leakage current less than 1mA.
- 4) The value is measured when voltage drops suddenly from nominal voltage to 0 VDC and coil is not paralleled with suppression circuit.
- 5) When energized, opening time of NO contacts shall not exceed 100μs.
- 6) FMVSS 302: Federal Motor Vehicle Safety Standard.
- 7) Since it is an environmental friendly product, please select lead-free solder when welding. The recommended soldering temperature and time is (260±3)°C,(10±0.3)s.
- 8) Only valid for QC version.
- 9) Test point is at 2mm away from terminal end, and after removing testing force, the terminal transfiguration shall not exceed 0.3mm.
- 10) Only for the 12VDC coil voltage type.
- 11) Do NOT knock on relays with hard objects such as rubber rod and rubber hammer during mounting, which might lead to relay damage.

CONTACT DATA ⁴⁾

Load voltage	Load type		Load current A	On/Off ratio		Electrical endurance OPS	Contact material	Load wiring diagram ³⁾	Ambient temp.
				On s	Off s				
Standard 13.5VDC	Resistive	Make	70	2	2	1×10 ⁵	AgSnO ₂	See diagram 1	at 23°C
		Break	70						
	Inductive	Make ¹⁾	150	2	4	1×10 ⁵	AgSnO ₂	See diagram 2	See Ambient temp. curve
		Break	50						
	Lamp ²⁾	Make	200	0.5	10	1×10 ⁵	AgSnO ₂	See diagram 3	
		Break	40						
Standard 27VDC	Resistive	Make	40	2	2	1×10 ⁵	AgSnO ₂	See diagram 1	at 23°C
		Break	40						

Notes: 1) Corresponds to the peak inrush current on initial actuation.

2) The load in the table excludes flasher. When applied in flasher, a special silver alloy (AgSnO₂) contact material should be used and the customer special code should be (170) as a suffix. Please heed the anode and cathode's request when wired, terminal 30 should connect with anode.

3) The load wiring diagrams are listed below:



HONGFA RELAY

ISO9001, IATF 16949, ISO14001, ISO45001, IECQ QC 080000, ISO/IEC 27001 CERTIFIED

2025 Rev. 2.00

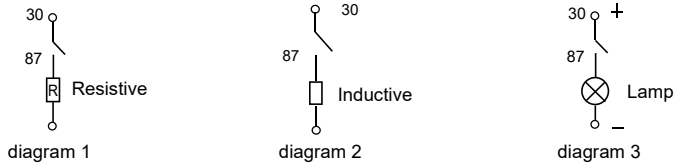

4) Loads mentioned in this chart is for relays with no parallel diode or Zener Diode. For those with parallel diode, Zener Diode or other components, please contact Hongfa for more technical supports.
Please also contact Hongfa if the actual application load is different from what mentioned above.

COIL DATA								at 23°C	
	Nominal voltage VDC	Pick-up voltage VDC max.	Drop-out voltage VDC min.	Coil resistance $x(1\pm 10\%)\Omega$	Parallel resistance $x(1\pm 5\%)\Omega$	Equivalent resistance Ω	Power consumption W	Max. allowable overdrive voltage ¹⁾ VDC	
								at 23°C	at 85°C
Standard	12	7.2	1.2	90	—	—	1.6	20.2	15.7
	12	7.2	1.2	90	680	79.5	1.8	20.2	15.7
	24	14.4	2.4	360	—	—	1.6	40.5	31.5
	24	14.4	2.4	360	2700	317.6	1.8	40.5	31.5
High power consumption	12	7.2	1.2	72	—	—	2.0	19	14
	12	7.2	1.2	72	680	65.1	2.2	18	14
	24	14.4	2.4	288	—	—	2.0	39	28
	24	14.4	2.4	288	2700	260.2	2.2	36	28

Notes: 1) Max. allowable overdrive voltage is stated with no load applied.

ORDERING INFORMATION	
Type	HFV7 / 012- H 4 S P T M -R (L) (XXX) HFV7: QC type HFV7-P: PCB type
Coil voltage	012: 12VDC 024: 24VDC
Contact arrangement	H: 1 Form A
Version	4: Plastic Bracket 6: Metal Bracket Nil: No Bracket
Construction ¹⁾	S: Plastic sealed ²⁾ Nil: Dust protected
Coil power	P: High power consumption Nil: Standard
Contact material	T: AgSnO ₂
Length of terminal	M: Short terminal & QC type 14.5mm Nil: Long terminal & QC type 17mm, or PCB type
Parallel coil ³⁾ components	R: Parallel transient suppression resistors D: Parallel transient suppression diode, with anode connected to terminal#85 D1: Parallel transient suppression diode, with anode connected to terminal#86 Nil: Without parallel components
Load type	(L): Low load type 40A (Only for 12VDC and QC type) Nil: Standard type 70A
Special code ⁴⁾	XXX: Customer special requirement Nil: Standard

Notes: 1) In environments with high humidity, moisture, or even condensation, and dust, such as relays used in engineering, mining, agriculture and other fields, or relays with mounting brackets installed outside of electrical boxes, It is recommended to use plastic-encapsulated products; in environments containing phosphorus, H₂S, SO₂, NO₂ and other harmful gases, plastic-encapsulated types must be used and tested and confirmed in actual use; in environments containing organic silicon, please avoid using dust-proof covers ;
2) Contact is recommended for suitable condition and specifications if water cleaning or surface process is involved in assembling relays on PCB.
3) If parallel diode, Zener Diode or other components are required, please contact Hongfa for more technical supports.
4) The performance parameters of products with characteristic numbers shall be subject to the specific specifications provided by Hongfa.

OUTLINE DIMENSIONS AND WIRING DIAGRAM

Unit: mm

Outline Dimensions

HFV7/□□□-H□□□-□□(XXX)

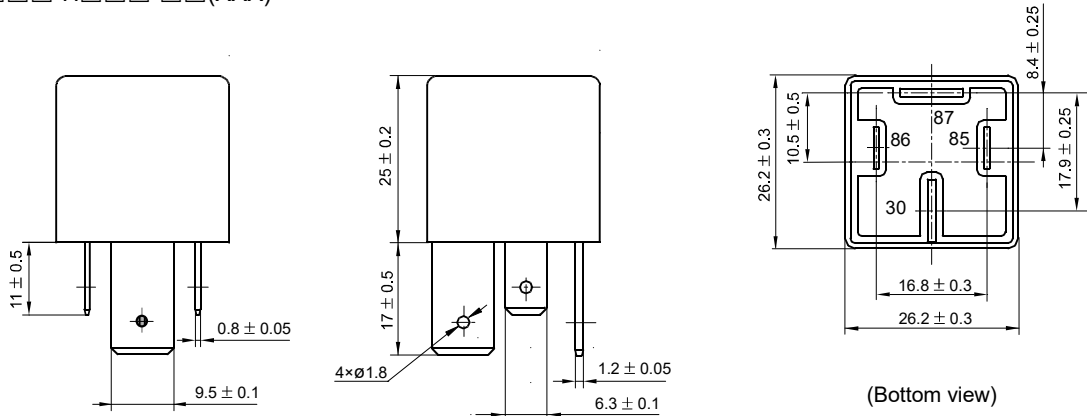

HFV7/□□□-H□□□M-□□(XXX)

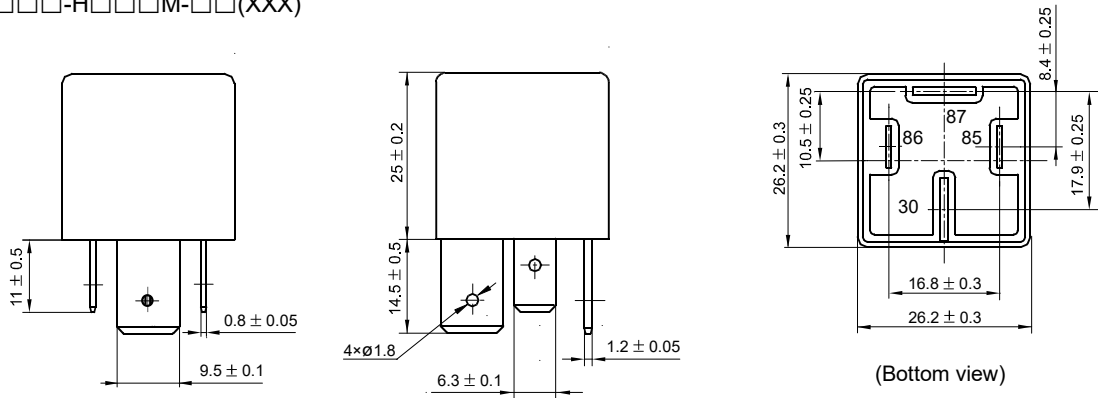

HFV7-P/□□□-H□□□-□(XXX)

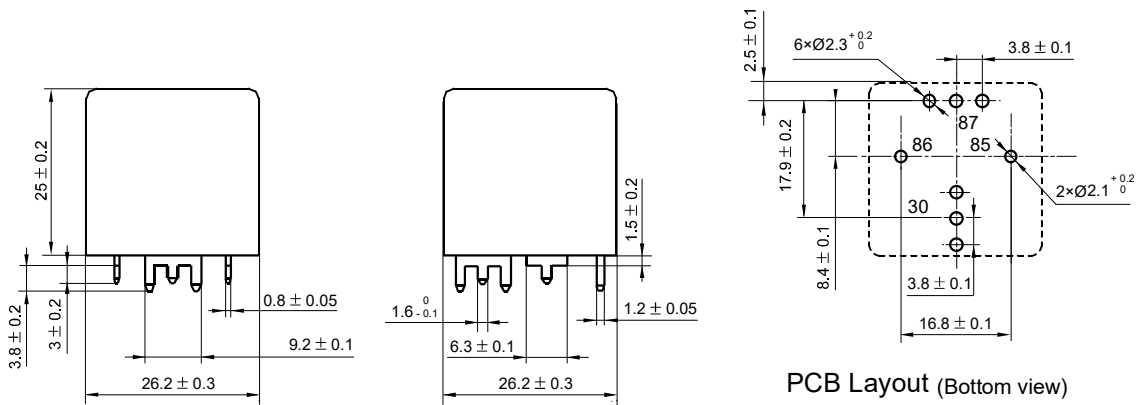

OUTLINE DIMENSIONS

Unit: mm

Outline Dimensions

HFV7/□□□-H4□□□-□□(XXX)

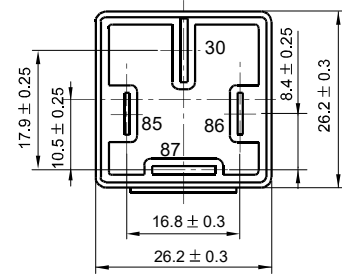
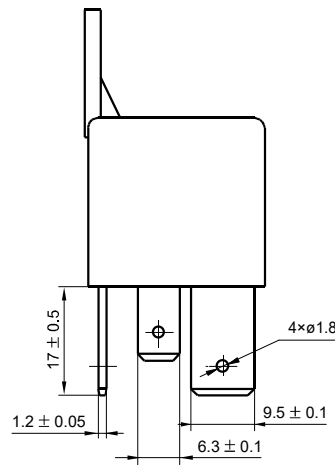
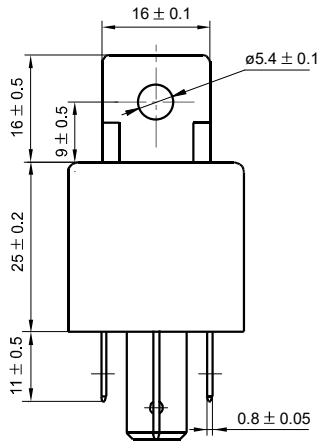

(Bottom view)

HFV7/□□□-H6□□□-□□(XXX)

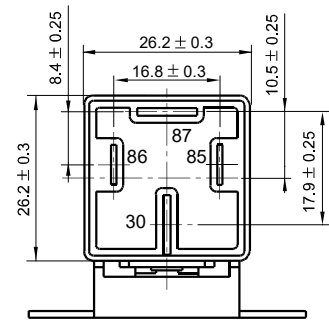
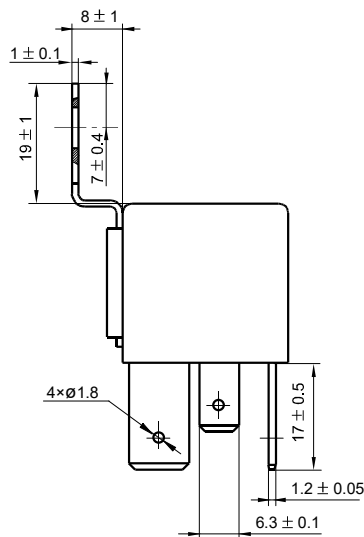
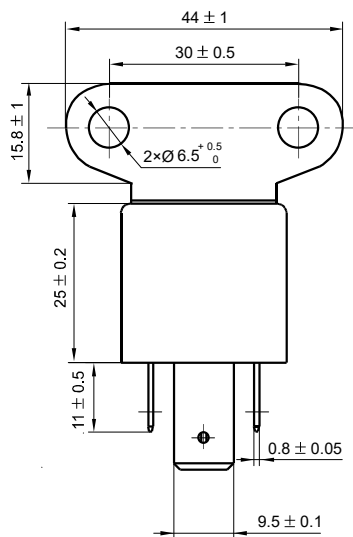

(Bottom view)

HFV7/□□□-H6□□□M-□□(311)(XXX)

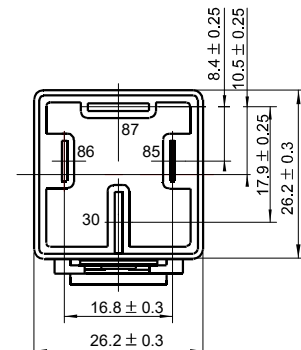
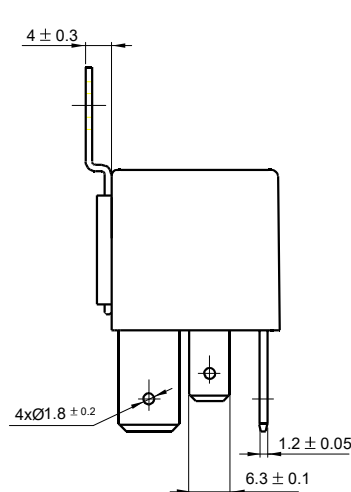
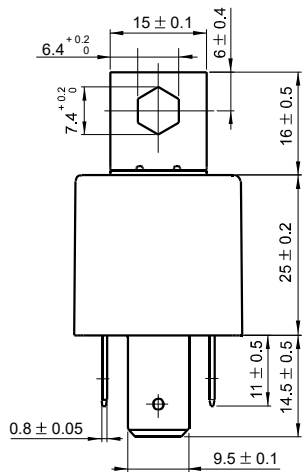

(Bottom view)

Remark: Terminal vertical deviation tolerance is 0.3mm.

Wiring Diagram

HFV7/□□□-H□□□□(XXX)

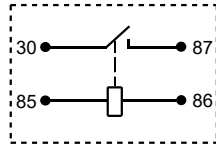

HFV7/□□□-H□□□□-D(XXX)

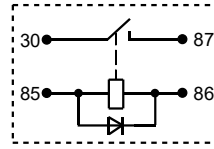

HFV7/□□□-H□□□□-R(XXX)

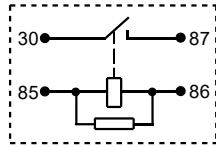

HFV7/□□□-H□□□□-D1(XXX)

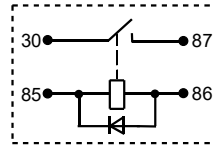

HFV7/□□□-H6□□□-□□(311)(XXX)

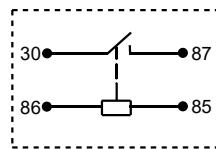

CHARACTERISTIC CURVES

1. Coil operating voltage range

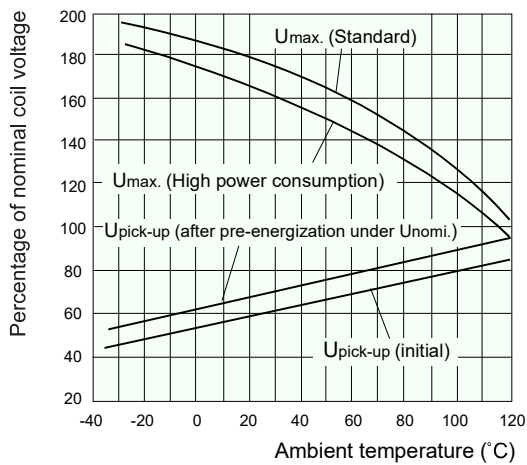

- 1) There should be no contact load applied when maximum continuous operation voltage is applied on coil.
- 2) The operating voltage is connected with coil energized time and voltage. After energized, the operating voltage will increase.
- 3) The maximum allowable coil temperature is 180°C. For the coil temperature rise which is measured by resistance is average value, we recommend the coil temperature should be below 170°C under the different application ambient, different coil voltage and different load etc.
- 4) If the actual operating coil voltage is out of the specified range, please contact Hongfa for further details.

CHARACTERISTIC CURVES

2. Load limit curve

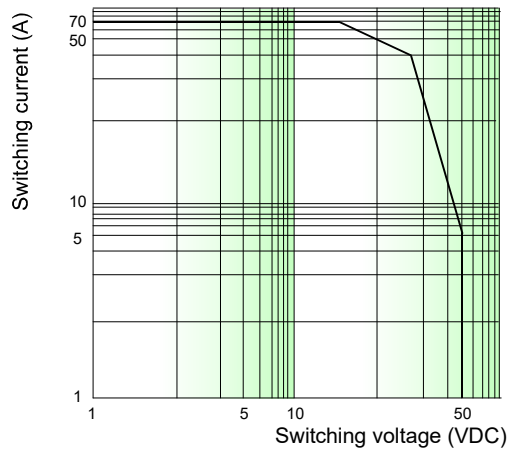

- 1) The contact load is resistive.
- 2) The load and electrical endurance tests are made according to "CONTACT DATA" parameters' table. If actual load voltage, current, or operate frequency is different from "CONTACT DATA" table, please arrange corresponding tests for confirmation.

3. Ambient temperature curve of the electrical endurance test

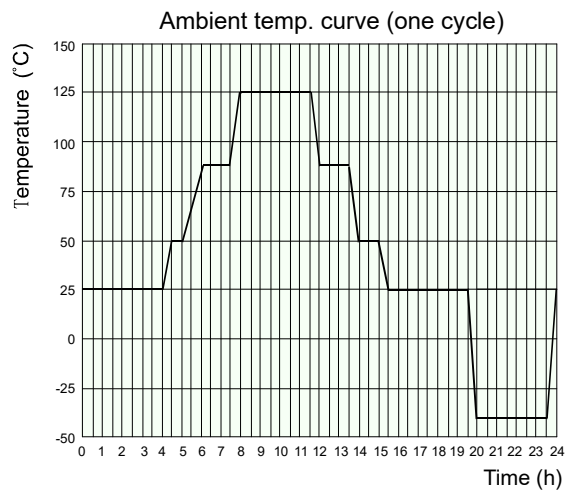

- 1) The minimum temperature is -40°C.
- 2) The maximum temperature is 125°C.

Disclaimer

The specification is for reference only. See to "Terminology and Guidelines" for more information. Specifications subject to change without notice. In case there is specific criterion (such as mission profile, technical specification, PPAP etc.) checked and agreed by and between customer and Hongfa, this specific criterion should be taken as standard regarding any requirement on Hongfa product.

We could not evaluate all the performance and all the parameters for every possible application. Thus the user should be in a right position to choose the suitable product for their own application. If there is any query, please contact Hongfa for the technical service. However, it is the user's responsibility to determine which product should be used only.

© Xiamen Hongfa Electroacoustic Co., Ltd. All rights of Hongfa are reserved.