

HFD53-TC

MINIATURE ULTRA HIGH-TEMPERATURE 8GHZ HIGH FREQUENCY RELAY



Features

- The maximum operating environment temperature reaches 155°C
- An ideal device to replace small high-frequency reed relays, capable of transmitting differential signals above 8GHz
- Operate/Release time ≤ 2ms
- Products with electrical endurance ≥ 1×10⁸ ops available
- Excellent high-frequency characteristics at 3.6GHz, Insertion loss ≤ 0.6dB, VSWR ≤ 1.4, Isolation: between open contacts ≥ 18dB, between contact sets ≥ 20dB.
- Excellent high-frequency characteristics at 8GHz: Insertion loss ≤ 3dB, VSWR ≤ 3, Isolation: between open contacts ≥ 12dB, between contact sets ≥ 15dB.
- Smallest size in high-frequency relay industry: 9.3mm × 5.1mm × 5.5mm

RoHS compliant

CONTACT DATA

Contact arrangement	2C	
Contact resistance	150mΩ max. (10mA 30mVDC)	
Contact material	Ag alloy + Au plated	
Contact rating	Resistive load	0.3A 125VAC/0.3A 30VDC
	High frequency load	1W 8GHz (V.SWR ≤ 1.2)
Max. switching voltage	125VAC/60VDC	
Max. switching current	0.5A (30VDC)	
Max. switching power	1W 8GHz (V.SWR ≤ 1.2)	
Max. throughput power	1W 8GHz (V.SWR ≤ 1.2)	
Min. applicable load ²⁾	10mV 10μA	
Mechanical endurance	3×10 ⁷ OPS	
Electrical endurance ⁶⁾	Resistive load	1×10 ⁵ OPS (0.3A 30VDC, 155°C, 1s on 9s off, NO or NC)
	High frequency load	1×10 ⁵ OPS (1W 8GHz ³⁾ , 155°C, 1s on 9s off, NO or NC)
	AR8 type	1×10 ⁸ OPS (40°C, 0.1s on 0.1s off, 2 form NO or NC in parallel, 10mA 5VDC) ⁴⁾

- Notes:** 1) The data shown above are initial values.
 2) Min. applicable load is reference value. Please perform the confirmation test with the actual load before production since reference value may change according to switching frequencies, environmental conditions and expected contact resistance and reliability.
 3) These values are for a V.SWR of 1.2 max. at the load.
 4) Wiring diagrams (bottom view) for two sets of NO or NC parallel are as follows:

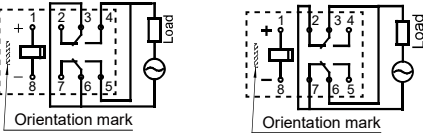

- 5) For low level and long durability applications, it is recommended to use two sets of NO or NC in parallel. If you need to use a single set of NO or NC, please contact our company.
 6) The table shows the typical electrical endurance. For more information, please contact our company.

COIL

Coil power	Single-side stable	See "COIL DATA"
	1 coil latching	See "COIL DATA"
Temperature rise	25K max. (0.3A load, ambient temperature 155°C)	

CHARACTERISTICS

Insulation resistance		1000MΩ (500VDC)
Dielectric strength	Between open contacts	500VAC 1min
	Between coil & contacts	750VAC 1min
	Between contact sets	750VAC 1min
	Between coil, contact and grounding	500VAC 1min
Operate time (Set time)		2ms max.
Release time (Reset time)		2ms max.
Ambient temperature		-40°C to 155°C
Humidity		5% to 85% RH
Vibration resistance	Functional	735m/s ²
	Destructive	980m/s ²
Shock resistance	Functional	10Hz to 55Hz 3.3mm DA
	Destructive	10Hz to 55Hz 5.0mm DA
Termination		SMT
Unit weight		Approx .0.7g
Moisture sensitivity levels ²⁾		MSL-3
Construction		Plastic sealed

- Notes:** 1) The data shown above are initial values.
 2) Only for SMT type, JEDEC-STD-020.

HIGH-FREQUENCY CHARACTERISTICS

Frequency	3.6GHz	8GHz (typical value)
Isolation	Between open contacts	≥ 18dB / ≥ 12dB
	Between contact sets	≥ 20dB / ≥ 15dB
Insertion loss	≤ 0.6dB	≤ 3dB
V.SWR	≤ 1.4	≤ 3
Max. throughput power	1W 8GHz (V.SWR ≤ 1.2)	

- Notes:** 1) The characteristic impedance of the measuring system is 50Ω;
 2) The data shown above are initial values.
 3) Please contact us if the relay will be used in an application that requires radio repeatability in high-frequency characteristics for the microload area (such as test and measurement equipment and ATE, etc.)
 4) These values are for a V.SWR of 1.2 max. at the load.



HONGFA RELAY

ISO9001, IATF16949, ISO14001, ISO45001, IECQ QC 080000, ISO/IEC 27001 CERTIFIED

2026 Rev. 1.00

COIL DATA

23°C

Single side stable · Standard type

Coil Code	Nominal Voltage VDC	Pick-up Voltage VDC max.	Drop-out Voltage VDC min.	Coil Resistance Ω	Rated Coil Current mA	Nominal Power mW approx.	Max. ⁵⁾ Voltage VDC
HFD53-TC/1.5	1.5	1.13	0.15	28×(1±10%)	53.3	80	2.3
HFD53-TC/2.4	2.4	1.80	0.24	72×(1±10%)	33.3	80	3.6
HFD53-TC/3 ³⁾	3.0	2.25	0.30	112.5×(1±10%)	26.7	80	4.5
HFD53-TC/4.5	4.5	3.38	0.45	253×(1±10%)	17.8	80	6.8
HFD53-TC/5 ³⁾	5.0	3.75	0.50	313×(1±10%)	16.0	80	7.5
HFD53-TC/6	6.0	4.50	0.60	450×(1±10%)	13.3	80	9.0
HFD53-TC/9	9.0	6.75	0.90	1013×(1±10%)	8.9	80	13.5
HFD53-TC/12	12.0	9.00	1.20	1800×(1±10%)	6.7	80	18.0
HFD53-TC/24	24.0	18.00	2.40	5760×(1±10%)	4.2	100	36.0

1 coil latching · Standard type

Coil Code	Nominal Voltage VDC	Pick-up Voltage VDC max.	Drop-out Voltage VDC max.	Coil Resistance Ω	Rated Coil Current mA	Nominal Power mW approx.	Max. ⁵⁾ Voltage VDC
HFD53-TC/1.5-L	1.5	1.13	1.13	28×(1±10%)	53.3	80	2.3
HFD53-TC/2.4-L	2.4	1.80	1.80	72×(1±10%)	33.3	80	3.6
HFD53-TC/3-L ³⁾	3.0	2.25	2.25	112.5×(1±10%)	26.7	80	4.5
HFD53-TC/4.5-L	4.5	3.38	3.38	253×(1±10%)	17.8	80	6.8
HFD53-TC/5-L ³⁾	5.0	3.75	3.75	313×(1±10%)	16.0	80	7.5
HFD53-TC/6-L	6.0	4.50	4.50	450×(1±10%)	13.3	80	9.0
HFD53-TC/9-L	9.0	6.75	6.75	1013×(1±10%)	8.9	80	13.5
HFD53-TC/12-L	12.0	9.00	9.00	1800×(1±10%)	6.7	80	18.0
HFD53-TC/24-L	24.0	18.00	18.00	5760×(1±10%)	4.2	100	36.0

Notes: 1) The data shown above are initial values.

2) To supply rated step voltage to coil is the foundation of relay proper operation. Please make sure the applied voltage to the coil reach at rated values.

Please refer to the typical diagram below for single side stable relay. The "V_{coil}" is the rated voltage:

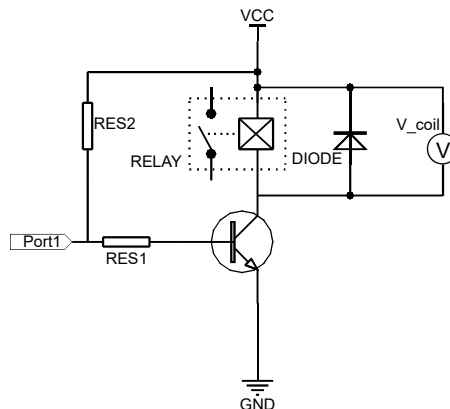

3) In case 5V of transistor drive circuit, it is recommended to use 4.5V type relay, and 3V to use 2.4V type relay.

4) For monostable relays, if you need to reduce the voltage for holding after reliably operating, make sure that the effective value of holding voltage is not less than 60% of the rated voltage.

5) Maximum voltage refers to the maximum over voltage which relay coil could endure in a short period of time.

6) When user's requirements can't be found in the above table, special order allowed.

7) During the relay pick-up or drop-out processes, there are stages of contact pressure change, contact vibration and unstable contact etc. When the voltage applied to coil is gradually changed, it will lengthen the unstable stage and affect relay endurance. To reduce this influence, please apply step voltage (switching circuit) to relay coil.

ORDERING INFORMATION

Type	HFD53-TC/	12	-L	S	R	(XXX)
Coil voltage	1.5, 2.4, 3, 4.5, 5, 6, 9, 12, 24VDC					
Sort	L: 1 coil latching Nil: Single side stable					
Terminal type	S: Standard SMT					
Packing style	R: Tape and reel packing ¹⁾					

XXX: Customer special requirement

Special code³⁾ For instance: (AR8) indicates that the product's electrical endurance is $\geq 1 \times 10^8$ OPS.

Notes: 1) R type (tape and reel) packing is moisture-proof which meets requirement of MSL-3. Please choose R type packing for SMT products. For R type, the letter "R" will only be printed on packing tag but not on relay cover. Tube packing is normally not available for SMT products unless specially requested by customer. But please note that tube packing is not moisture-proof so please bake the products before use according to description of Notice 11 herewith. In addition, tube packaging will be adopted when the ordering quantity of R type is equal to or less than 100 pieces unless otherwise specified.

2) A hyphen mark "-" should be added between coil voltage and sort/terminal type/packing style if any, for example: HFD53-TC/12-SR;

3) The customer's special requirements will be identified by special codes after evaluation.

OUTLINE DIMENSIONS, WIRING DIAGRAM AND PC BOARD LAYOUT

Unit: mm

S type: Standard SMT

Outline Dimensions

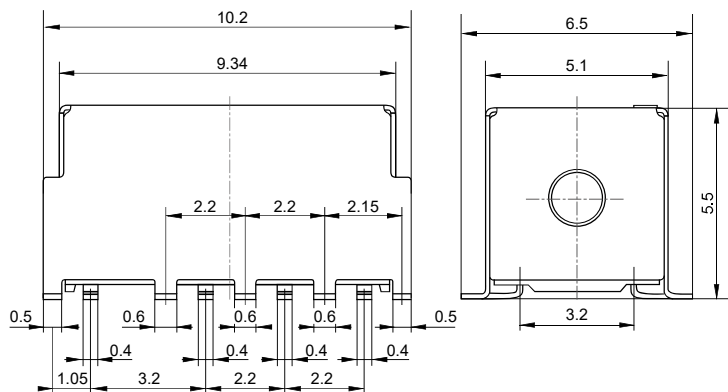

PCB Layout
(Bottom view)

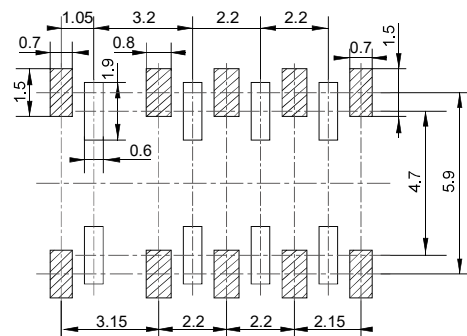

Pin Layout
(Single side stable & 1 coil latching)

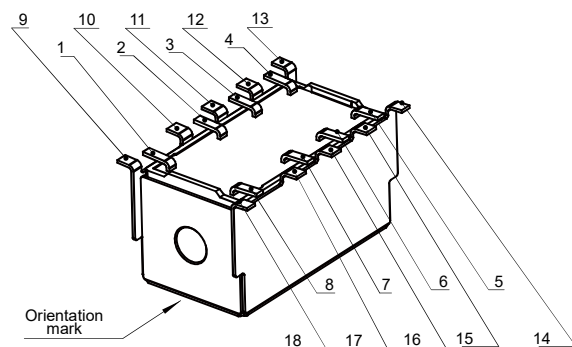
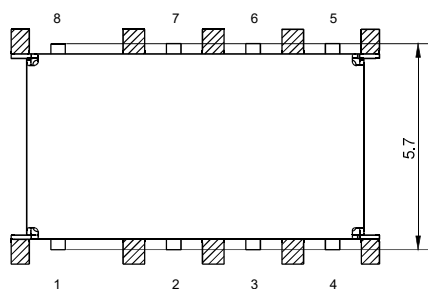

Remark: 1)  represents the ground terminal or ground mounting hole.

OUTLINE DIMENSIONS, WIRING DIAGRAM AND PC BOARD LAYOUT

Unit: mm

Wiring Diagram (Bottom view)

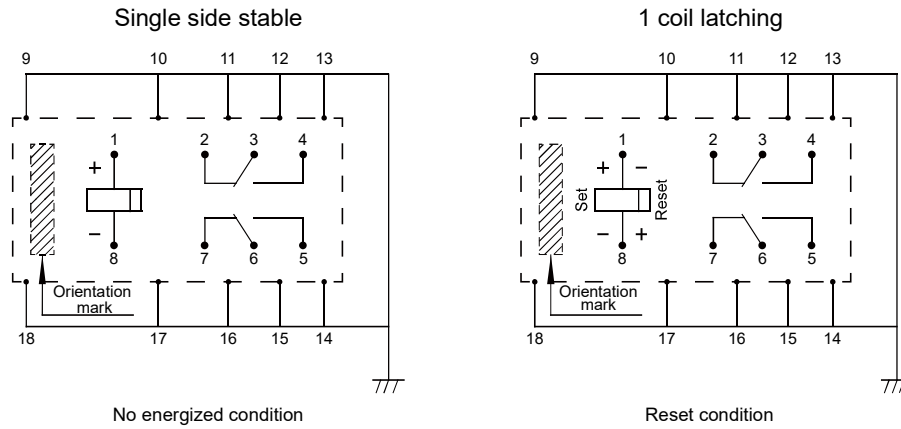

- Notes:** 1) In case of no tolerance shown in outline dimension: outline dimension $\leq 1\text{mm}$, tolerance should be $\pm 0.2\text{mm}$; outline dimension $> 1\text{mm}$ and $\leq 5\text{mm}$, tolerance should be $\pm 0.3\text{mm}$; outline dimension $\geq 5\text{mm}$, tolerance should be $\pm 0.4\text{mm}$.
2) The tolerance without indicating for PCB layout is always $\pm 0.1\text{mm}$.

TAPE PACKING

Unit: mm

Direction of Relay Insertion

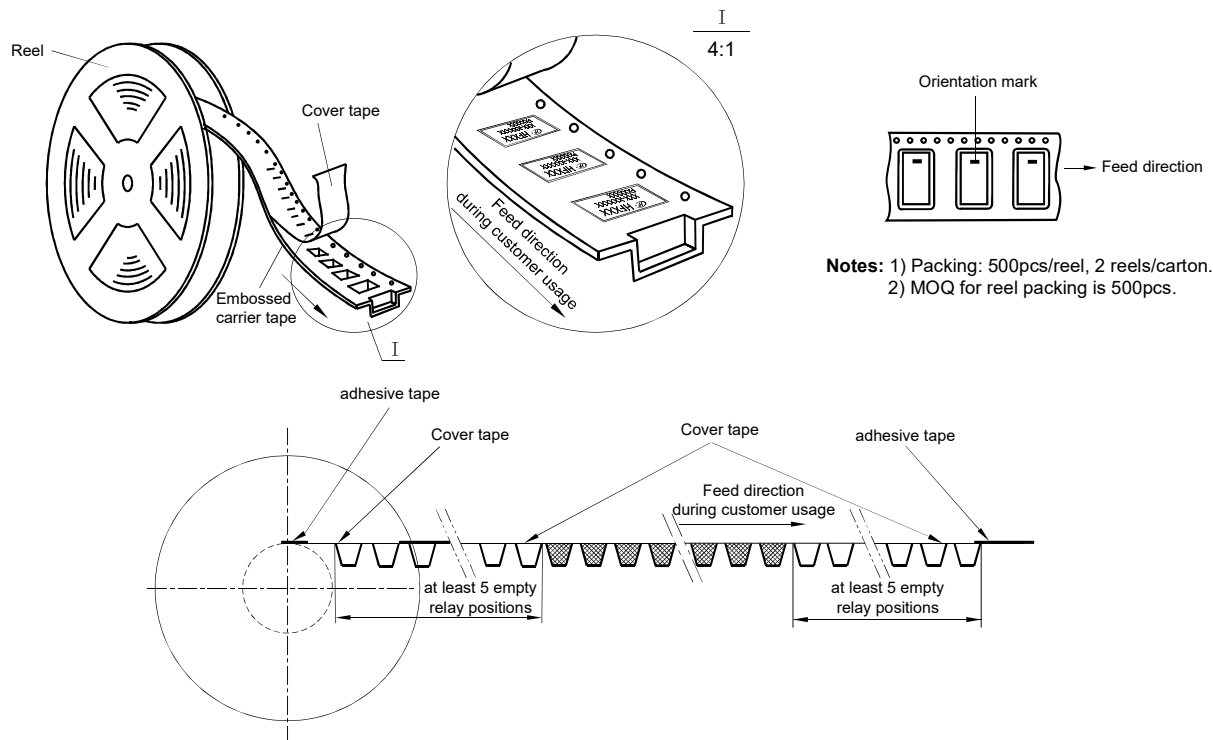

- Notes:** 1) Packing: 500pcs/reel, 2 reels/carton.
2) MOQ for reel packing is 500pcs.

Reel Dimensions

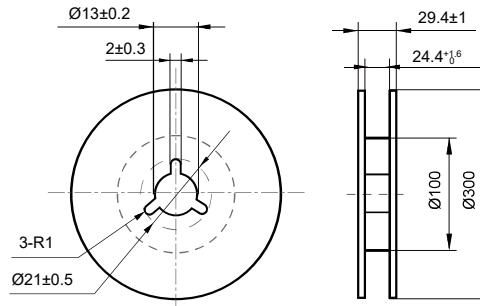

Tape Dimensions
(S type: Standard SMT)

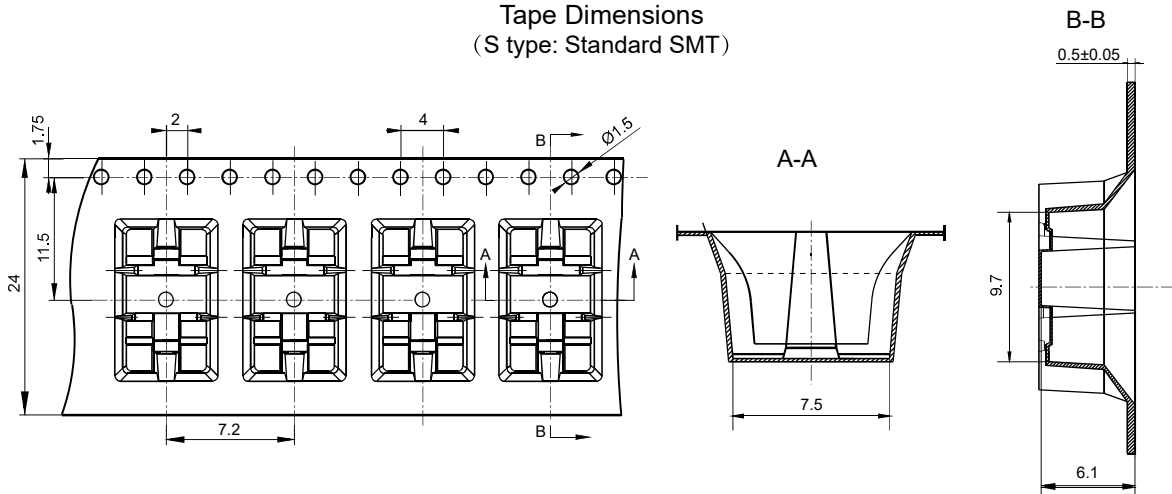

HIGH FREQUENCY CHARACTERISTICS CURVES

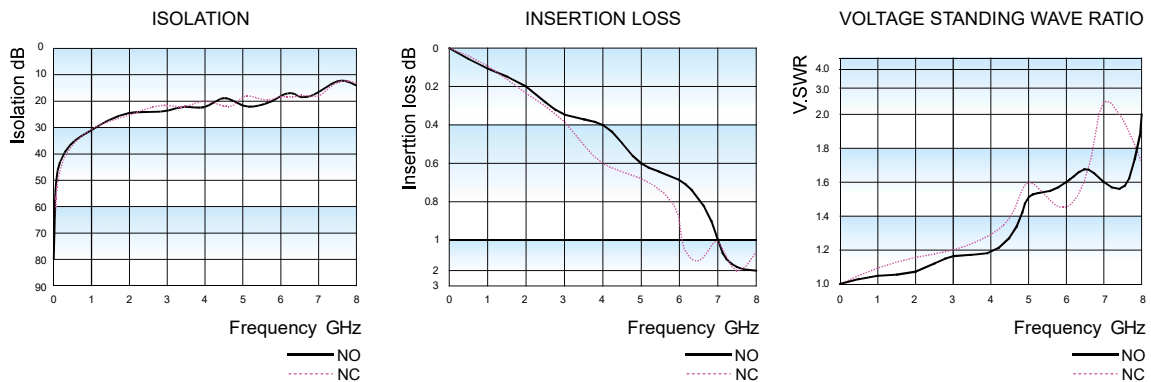

- Notes:**
- 1) Ambient temperature conditions is 23°C;
 - 2) The data shown above are initial values.
 - 3) The high-frequency characteristics will vary depending on the PCB board. Please be sure to check performance parameters including durability in actual equipment before use.
 - 4) Test model and specification: HFD53-TC/4.5-SR, test instrument: Keysight E5071C network analyzer, the characteristic impedance of the measurement system is 50Ω.

8 Gbps EYE DIAGRAM

NO contacts

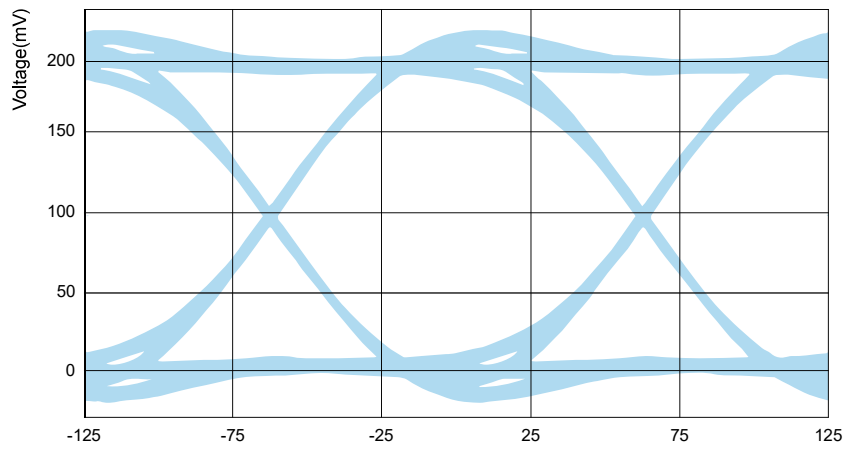

Eye Height	Eye Width	Jitter P-P
161.4 mV	119.4 ps	5.6 ps

NC contacts

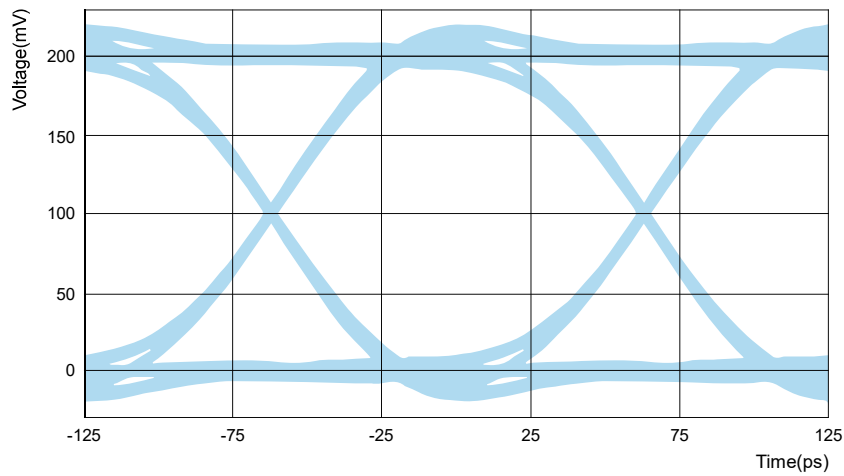

Eye Height	Eye Width	Jitter P-P
156.3 mV	118.9 ps	5.6 ps

Test conditions:

- 1) $2^{11}-1$ PRBS signal.
- 2) Input differential voltage 200 mV.
- 3) Rise time 58.8ps @10-90%.
- 4) Ambient temperature condition:23°C
- 5) The impedance of the measurement system is 50Ω.
- 6) This data includes loss due to the test board.

CHARACTERISTIC CURVES

REFLOW SOLDERING, TEMPERATURE ON PCB BOARD RECOMMENDED SOLDERING TEMPERATURE

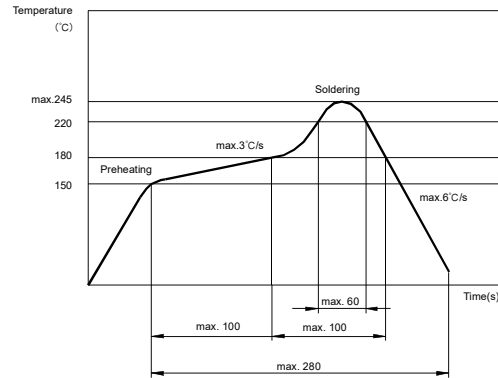

- Notice :**
- 1) This relay is highly sensitive polarized relay, if correct polarity is not applied to the coil terminals, the relay does not operate properly.
 - 2) To avoid using relays under strong magnetic field which will change the parameters of relays such as pick-up voltage and drop-out voltage.
 - 3) Relay is on the "reset" status when being released from stock, with the consideration of shock risen from transit and relay mounting, it should be changed to the "set" status when application(connecting to the power supply). Please reset the relay to "set" or "reset" status on request.
 - 4) The relay action voltage and release/return voltage are the initial values tested under standard conditions (23 C). Applying rated voltage to both ends of the relay coil is the basis for normal operation of the relay. Considering the influence of environment temperature, coil temperature rise (such as hot start), voltage fluctuation, etc., in order to ensure the safety margin, make sure that the voltage applied to both ends of the relay coil reaches the rated voltage before use. For a latching relay, the pulse width of the rated voltage applied to both ends of the relay coil must be more than five times of the set or reset time in order to ensure its operate or release.
 - 5) For single-side stable relays, if voltage drop is needed to maintain the operation of relay after the relay operates reliably, please ensure that the effective value of the holding voltage is not less than 60% of the rated voltage.
 - 6) The relay may be damaged because of falling or when shocking conditions exceed the requirement.
 - 7) For SMT products, validation with real application should be done before your series production, if the reflow-soldering temperature curve is out of our recommendation. Generally, two-time reflow-soldering is not recommended for the relay. However, if two-time reflow-soldering is required, a 60-min. interval should be guaranteed and a validation should be done before production.
 - 8) Please use wave soldering or manual soldering for straight-in relay. If you need reflow welding, please confirm the feasibility with us.
 - 9) Contact is recommended for suitable condition and specifications if water cleaning or surface process is involved in assembling relays on PCB.
 - 10) Regarding the plastic sealed relay, we should leave it cooling naturally until below 40°C after welding, then clean it and deal with coating, remarkably the temperature of solvents should also be controlled below 40°C. Please avoid cleaning the relay by ultrasonic, and using the solvents like gasoline, Freon, and so on, which would affect the configuration of relay or influence the environment.
 - 11) For relays with moisture-proof package, the package meets requirements of MSL-3. After opening the package, please store the relays in an environment of $\leq 30^{\circ}\text{C}$, $\leq 60\%$ RH, and use them within 168 hours. If the relays can't be used up in time it's recommended to repack them with vacuum packaging or store them in a drying oven of $25^{\circ}\text{C} \pm 5^{\circ}\text{C}$, $\leq 10\%$ RH. If the storage conditions exceed the mentioned conditions, please perform actual soldering to confirmation or bake the relays at $50^{\circ}\text{C} \pm 5^{\circ}\text{C}$, $\leq 30\%$ RH for 72 hours before use.
 - 12) When the relay is used in a long-term continuous energized circuit, the coil insulation material will age due to the self-heating of the coil. Therefore, please try not to ground the relay coil to reduce the risk of electrical corrosion. At the same time, please design an appropriate safety circuit to prevent losses due to disconnection.
 - 13) Please make sure that there are no silicon-based substances (such as silicon rubber, silicone oil, silicon-based coating agents, silicon fillers, etc.) around the relay, because it will generate silicon-containing volatile gas, which may cause poor contact in case of silicon-containing volatile gas sticking on contact.
 - 14) For other recommended usage, storage and transportation conditions, please refer to "Relay Terminology Explanation and Selection Guide".
 - 15) During the relay pick-up or drop-out processes, there are stages of contact pressure change, contact vibration and unstable contact etc. When the voltage applied to coil is gradually changed, it will lengthen the unstable stage and affect relay endurance. To reduce this influence, please apply step voltage (switching circuit) to relay coil.

Disclaimer

The specification is for reference only. See to "Terminology and Guidelines" for more information. Specifications subject to change without notice. We could not evaluate all the performance and all the parameters for every possible application. Thus the user should be in a right position to choose the suitable product for their own application. If there is any query, please contact Hongfa for the technical service. However, it is the user's responsibility to determine which product should be used only.