



# 16F Series

# Push-In Relay Socket



### Features

- Dielectric strength: Up to 4000V AC, Insulation Resistance 1000MΩ
- With finger protection device
- Relay retention and ejection for reliable installation and removal
- Built-in protection circuit with power-on indication, protection and wide voltage input
- Max. wire size: solid wire / sheathed wire 1x(0.5-1.5)mm<sup>2</sup>
- Accessory Available: Marker, Jumper

RoHS compliant

### CHARACTERISTICS

Type	Nominal Voltage	Nominal Current	Ambient Temperature	Socket coil input voltage	Relay coil voltage	Input voltage polarity	Dielectric Strength min.	Wire Strip Length	Min. package qty.
16F-1Z-C10/P-1	250VAC	6A	-40°C ~ 70°C	(12 ~ 24)VAC/DC	(12~24)VDC	—	4000VAC 1min	12mm	10
16F-1Z-C10/P-2	250VAC	6A	-40°C ~ 55°C	(48 ~ 60)VAC/DC	(48~60)VDC	—	4000VAC 1min	12mm	10
16F-1Z-C10/P-3	250VAC	6A	-40°C ~ 55°C	(110 ~ 125)VAC/DC	60VDC	—	4000VAC 1min	12mm	10
16F-1Z-C10/P-4	250VAC	6A	-40°C ~ 55°C	(220 ~ 240)VAC/DC	60VDC	—	4000VAC 1min	12mm	10
16F-1Z-C10/P-5	250VAC	6A	-40°C ~ 55°C	(6~24)VDC	(6~24)VDC	✓	4000VAC 1min	12mm	10

### ORDERING INFORMATION

	16F	-1Z	-C10/P	(XXX)
<b>Type</b>				
<b>Contact arrangement</b>	<b>4Z: 4 Form C</b>			
<b>Termination &amp; mounting</b>	<b>C10/P: Push-in type with push-button</b>			
<b>Special code</b>	<b>XXX: Customer special requirement</b>		<b>Nil: Standard</b>	

Notes: 1) The customer special requirement express as special code after evaluating by Hongfa.

### OUTLINE DIMENSIONS, WIRING DIAGRAM AND PC BOARD LAYOUT

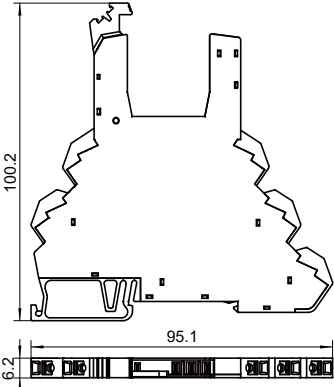
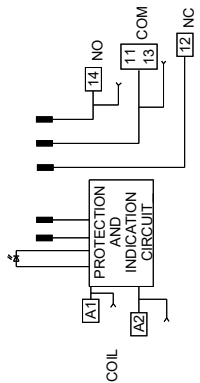
Socket (If need accessry, please order with type.)	Outline Dimensions	Wiring Diagram	Accessory Available
16F-1Z-C10/P-1/2/3/4  			<p>Marker: 41F-M 41F-M1</p> <p>Retainer: 41F-J1(blue) 41F-J1R(red) 41F-J1B(black)</p> <p>Plug-in module: 41F-S</p>

Next page



HONGFA RELAY

ISO9001、IATF16949、ISO14001、ISO45001、IECQ QC 080000 CERTIFIED

XP 2026 Rev. 1.00

## OUTLINE DIMENSIONS, WIRING DIAGRAM AND PC BOARD LAYOUT

Previous page

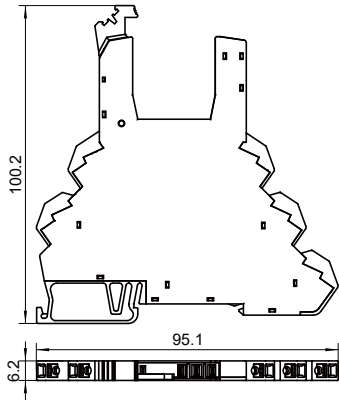
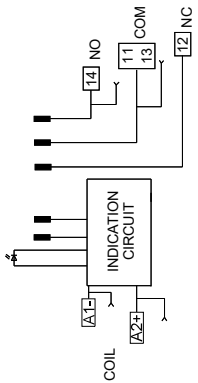
Socket (If need accessory, please order with type.)	Outline Dimensions	PCB Layout	Accessory Available
			<p>Marker: 41F-M 41F-M1</p> <p>Retainer: 41F-J1(blue) 41F-J1R(red) 41F-J1B(black) 41F-J2(blue) 41F-J2R(red)</p> <p>Plug-in module: 41F-S</p>

## DIMENSION OF RELATED ACCESSORY (AVAILABLE)

Unit: mm

### Marker

41F-M

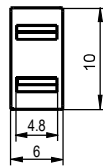

41F-M1

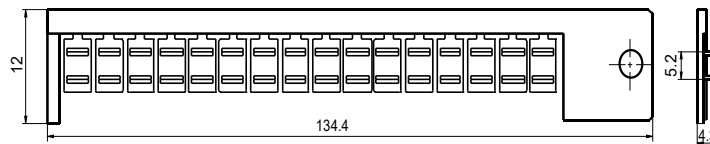

### Jumper

41F-J1(blue), 41F-J1R(red), 41F-J1B(black)

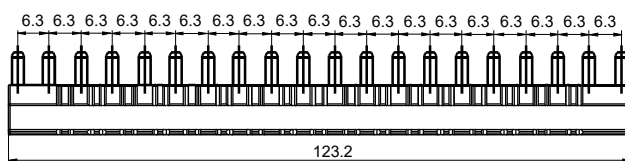

41F-J1(blue), 41F-J1R(red)

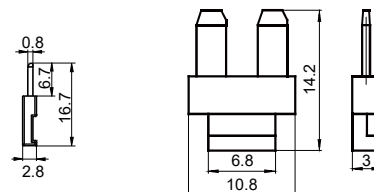

## DIMENSION OF RELATED ACCESSORY (AVAILABLE)

Unit: mm

Separator

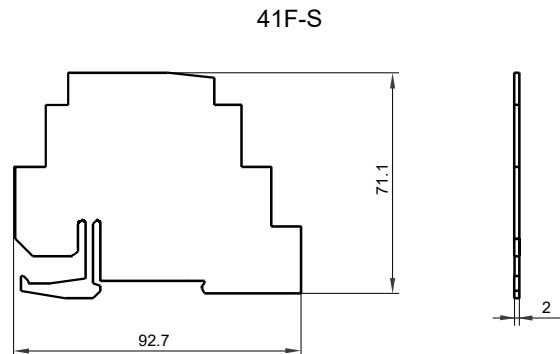

### Things to be noticed when selecting sockets:

1. Please choose suitable relay socket according to the actual mounting environment, relay contact poles and terminal layout. If there is any query on selection, please contact Hongfa for the technical service;
2. Relevant accessories must be selected separately. Please indicate the model of the selected accessories when ordering;
3. The above is only an example of typical socket and related component type which is suitable to HF16F relay. If you have any special requirements, please contact us.
4. Main outline dimension, outline dimension  $> 50\text{mm}$ , tolerance should be  $\pm 1\text{mm}$ ;  $20\text{mm} < \text{outline dimension} \leq 50\text{mm}$ , tolerance should be  $\pm 0.5\text{mm}$ ;  $5\text{mm} < \text{outline dimension} \leq 20\text{mm}$ , tolerance should be  $\pm 0.4\text{mm}$ ; outline dimension  $\leq 5\text{mm}$ , tolerance should be  $\pm 0.3\text{mm}$ ;
5. DIN rail mounting: recommend to use standard rail IEC60715 TH35-7.5. When installed vertically, the coil terminal at the bottom please. For non-standard rails, contact Hongfa.

## Precautions For Use

1. Please use the quick-break fuse with rating of 15Amp. for short-circuit protection.
2. It may cause failure, fire or malfunction, when the sockets is continuously applied the power to for a long term In case of exceeding the upper limit ambient temperature. So please ensure that the ambient temperature is within the upper limit
  - Operating temperature upper limit:  $55^{\circ}\text{C}$ : 16F-1Z-C10/P-2/3/4/5
  - Operating temperature upper limit:  $70^{\circ}\text{C}$ : 16F-1Z-C10/P-1
3. Things to be noticed when selecting soft wiring.
  - The soft wiring can be divided into the following types:  
Sleeves line or single wire less than  $1.5\text{mm}^2$  or less than AWG16.  
Be sure to use this size that the front end of the wire needs to be stripped of the 12mm insulation protection layer.

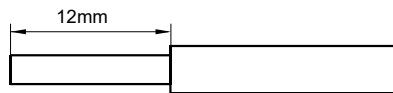

Figure 1

## Precautions For Use

- If the stripping protective layer is too short, it may cause the wire to be pulled out. If it is too long, it may have a short circuit with the adjacent wire. If the stranded wire of cold pressed terminal is used, please tighten the wire of stranded wire before use to avoid loose wire.
- Use the recommended screwdriver specifications when wiring.

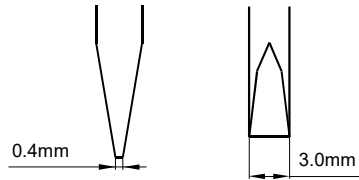

Figure 2

- The insertion position of the wire and the screwdriver and the insertion direction of the screwdriver are as shown in Figure 3.

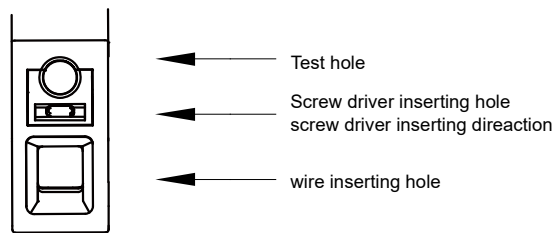

Figure 3

- Please use cold pressed terminals when selecting twisted line.
- The method of Wiring as shown in figure 4.  
Insert the wire into the wire insertion hole (circular hole) in the direction of (1) arrow,, and insert the wire straight into the bottom, as shown in (2).

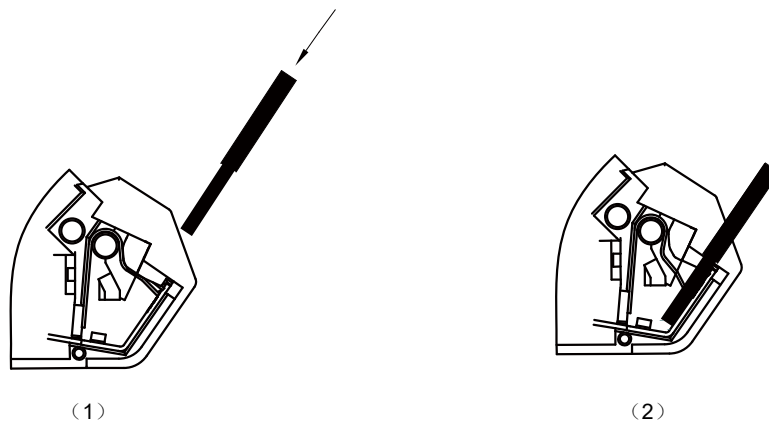

Figure 4

## Precautions For Use

- How to remove the wires in Figure 5

Insert the screwdriver into the screwdriver insertion hole (square hole) along the direction of the arrow in (1), and the screwdriver into the hole until the pressure spring is released after the wire, Remove the wire in the direction of arrow 2; after the wire is removed, release the button with the screwdriver.

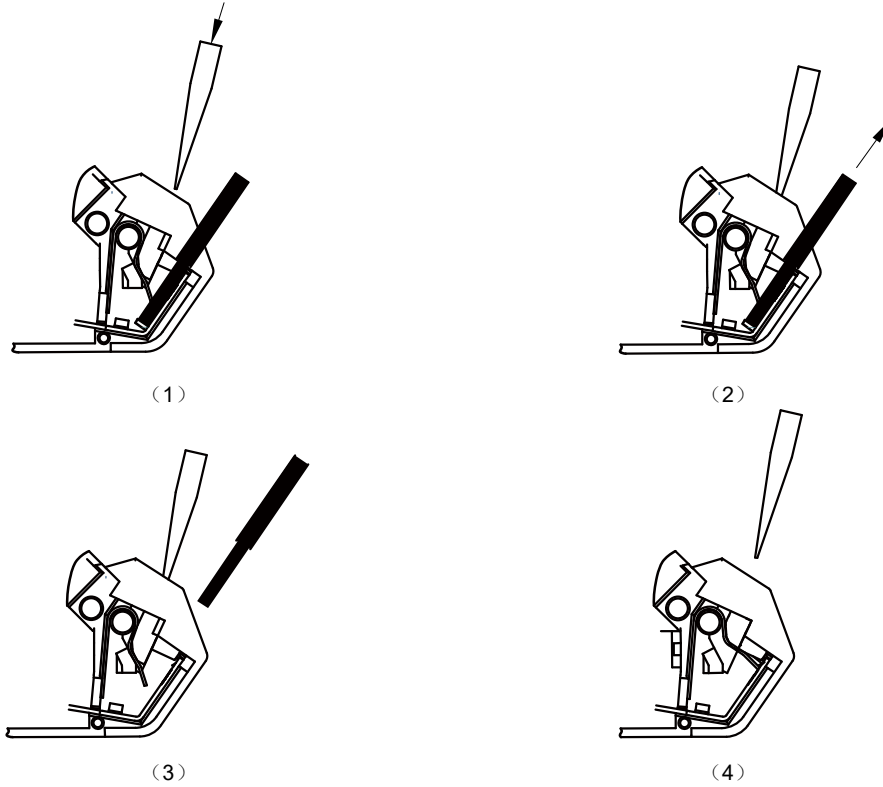

Figure 5

### 4. Mounting relay.

Presents the socket anti-stripping spring in an open state (see Figure 6), and aligns the relay to the main socket cavity (Figure 7). Then turn the buckle counterclockwise and press the relay gently until it is fully plugged into the socket (Figure 8).

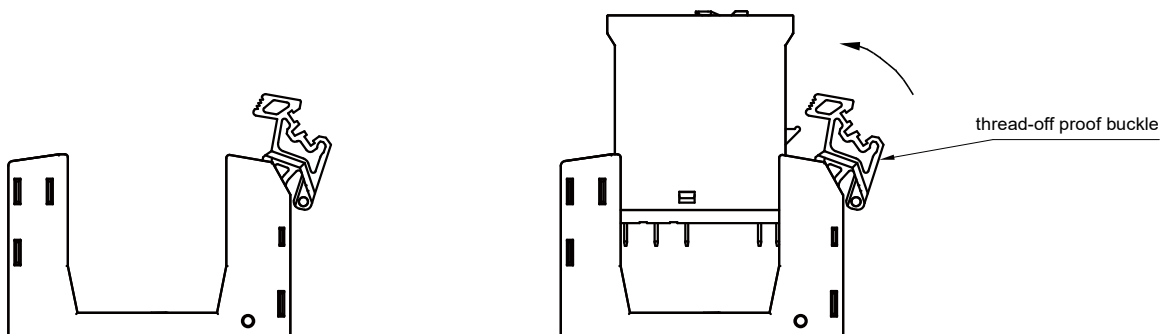

Figure 6

Figure 7

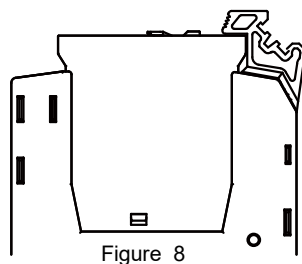

Figure 8

## Precautions For Use

### 5. Disassembly relay

Disconnect the relay by pulling the anti lock buckle of the socket clockwise (see Figure 9).

**Note:** When disassembling the relay, please note that the relay may be suddenly ejected and cause the relay to fall or be lost. Therefore, when disassembling the relay, be sure to squeeze the relay by hand before Pull the anti-release catch clockwise to disassemble the relay.

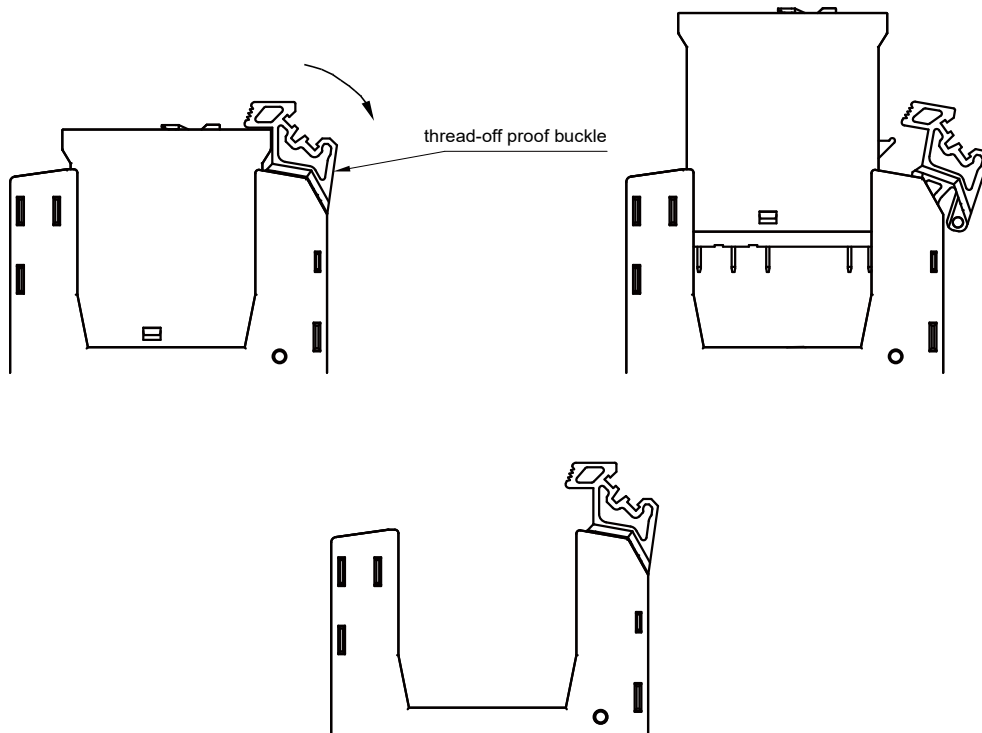

Figure 9

### 6. Installation socket

Insert the A of the socket into the rail and press it in the direction of the arrow.(Figure 10).

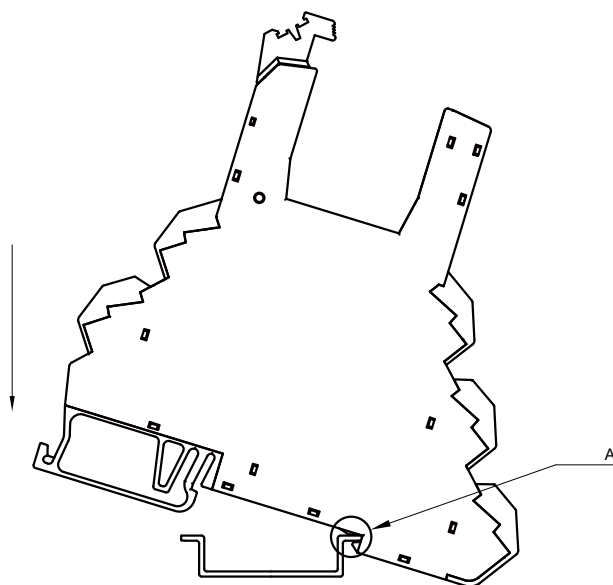

Figure 10

## Precautions For Use

### 7. Disassembly socket

Insert a screwdriver into B, turn in the direction of the arrow, lift the socket and remove the socket.(Figure 12)

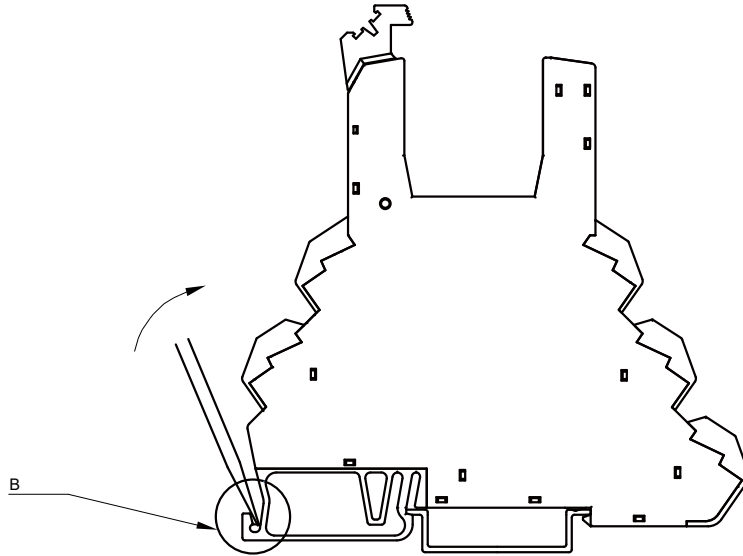

Figure 11

For your personal safety and the normal operation of the equipment, as well as to prevent fire, please note the following issues :

1. The rated current of the socket should be no less than the rated current of the relay.
2. Sockets are required to be firmly fixed to prevent the wiring from loosening and affecting the quality of wiring.
3. Be sure to disconnect power to the outlet before installation, disassembly, wiring, maintenance and inspection.
4. prevent foreign objects such as wire shavings from falling inside this product when wiring.
5. Be sure to install the relay in place, and use accessories such as retainer if necessary to improve contact reliability. Do not use with incomplete connections.
6. Be sure to observe the relay ratings and do not overload the relay.
7. Before selecting a relay, make sure that the drive voltage matches the relay excitation voltage.

### Disclaimer

The specification is for reference only. See to "Terminology and Guidelines" for more information. Specifications subject to change without notice. We could not evaluate all the performance and all the parameters for every possible application. Thus the user should be in a right position to choose the suitable product for their own application. If there is any query, please contact Hongfa for the technical service. However, it is the user's responsibility to determine which product should be used only.