

# HFE85P-300M

# DIRECT CURRENT RELAY



File No.:E133481

RoHS compliant



### Features

- Hermetically sealed with ceramic brazing technology, without risk of arc leaking, no fire or explosion.
- Filled with hydrogen gas to prevent oxidation and burn out of contacts; Low and stable contact resistance, contact block with IP67 compliant.
- 300A continuous carry current capability at 85°C.
- Max. insulation resistance up to 1000MΩ (1000 VDC), dielectric strength (betweencontact and coil) up to 3kVAC, IEC60664-1 compliant.
- Polarity is not required for the load but is required for the coil drive.
- Applied to the energy storage, safety conformity of ≤1500V.

### CONTACT DATA

Contact arrangement	1 Form A
Contact resistance <sup>1)</sup>	≤0.25mΩ(at 200A)
Contact rating	300A
Mechanical endurance	2 x 10 <sup>4</sup> ops(0.5s on:0.5s off)
Max. switching voltage	1500 VDC
Max. breaking current	2000A (450 VDC) 1 op
Max. switching power	450kW
Electrical endurance <sup>2)</sup>	Breaking:3000 ops(100A 500VDC)
	Breaking:1000 ops(300A 450VDC)
	Breaking:500 ops(300A 750VDC)
	Breaking:100 ops(300A 1000VDC)
	Switching:6000 ops(60A 1500VDC) <sup>3)</sup>
	Making:7.5x10 <sup>4</sup> ops(20VDC C=1100μf, Inrush current:140A)
Current carrying <sup>4)</sup> endurance	300A: Cont.
	450A: 400s
	600A: 150s
	1000A: 23s

Notes: 1) The above values are the initial values.

2) Unless otherwise specified, the temperature of electrical endurance is at 23°C and the on-off ratio is 0.6s:5.4s.

The energy-saving board is built in the relay. The coil will switch after 0.2 seconds of driving. However, repeated on-off operations within 0.2 seconds may cause failure. Products with built-in circuit boards cannot be driven by slow rising voltage. Please use fast rising edge (step power supply method) to drive the coil, otherwise it will not work!

3) Load condition for UL certified.

4) Ambient temperature is at 85°C and cross-sectional area of conductor is 100mm<sup>2</sup> min. See Fig. Endurance Capacity Curve for more information.

### AUXILIARY CONTACT

Contact arrangement	1 Form B
Contact resistance <sup>1)</sup>	≤150mΩ(at 1A)
Contact rating	6VDC 0.1A
Min. contact load	6VDC 3mA

### COIL

23°C

Rated Voltage VDC	Pick-up Voltage VDC	Drop-out Voltage VDC	Coil power W
12	≤9.6	≥1	Start-up:60 Holding:4.3
24	≤19.2	≥2	

### CHARACTERISTICS

Insulation resistance		1000MΩ(1000 VDC)
Dielectric strength	Between contact and coil	3000 VAC 1min
	Between open contacts	3000 VAC 1min
	Between main & auxiliary contacts	3000 VAC 1min
Operate time (at rated volt.)		≤30ms
Release time (at rated volt.)		≤10ms
Shock resistance	Functional	98m/s <sup>2</sup>
	Destructive	980m/s <sup>2</sup>
Vibration resistance		10Hz ~ 55Hz
Humidity		5% ~ 85% RH
Ambient temperature		-40°C ~ 85°C
Load terminal structure		M6 internal thread
Unit weight		Approx. 420g
Outline Dimensions		84.5x62.5x72.5mm

Note:The above values are the initial values measured at room temperature.



HONGFA RELAY

ISO9001、IATF16949、ISO14001、ISO45001、IECQ QC 080000、ISO/EC 27001 CERTIFIED 2026 Rev. 1.00

## ORDERING INFORMATION

Type	HFE85	P	-300	M	/XXX-	XX-	H	B	-C	5	-6 (XXX)
Application	P: PV and energy storage										
Contact rating	300: 300A										
Series breakdown	M: M Series										
Load voltage	Nil: 450 VDC 750: 750 VDC 1000: 1000 VDC 1500: 1500 VDC										
Coil voltage	12: 12 VDC 24: 24 VDC										
Contact arrangement	H: 1 Form A										
Aux. contact arrangement	B: 1 Form B										
Coil terminal arrangement	C: Connector										
Load terminal arrangement	5: Internal thread										
Coil characteristic	6: Double coil with PCBA										
Special code <sup>1)</sup>	XXX: Customer requirement(used when customers have special requirements)										

Note: 1) The customer's special requirement is expressed as a special code after evaluation by Hongfa.

## OUTLINE DIMENSIONS, MOUNTING HOLE, TERMINAL ARRANGEMENT

Unit: mm

### Outline Dimensions

HFE85P-300M/XXX-XX-HB-C5-6

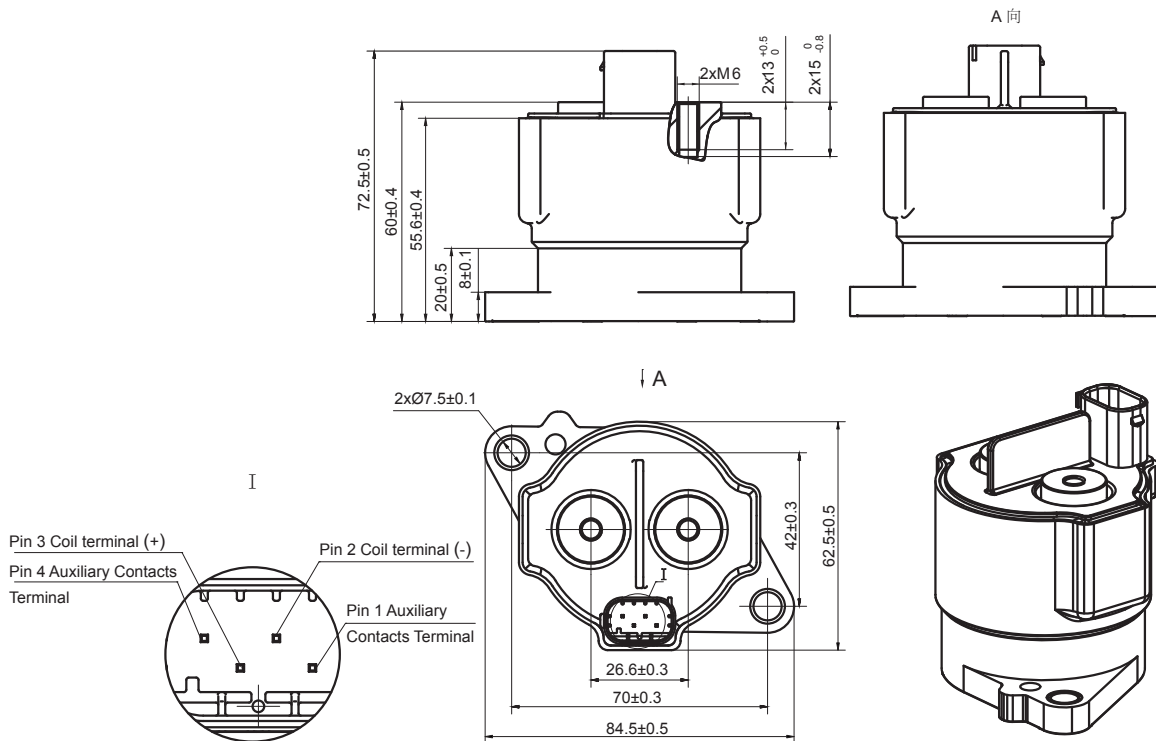

# OUTLINE DIMENSIONS, MOUNTING HOLE, TERMINAL ARRANGEMENT

Unit: mm

Mounting Hole

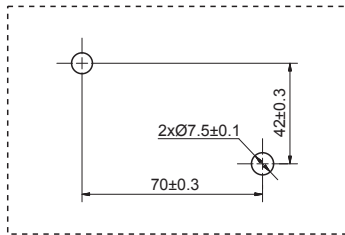

Wiring Diagram

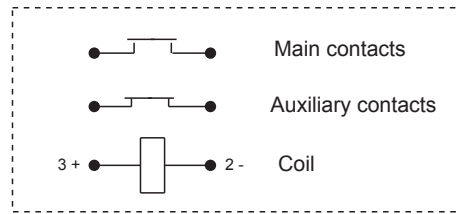

Note: Polarity on the coil, with no polarity on the main contacts and auxiliary contacts.

# COIL TERMINAL ARRANGEMENT

Unit: mm

## C:Connector

(Configured by customers)

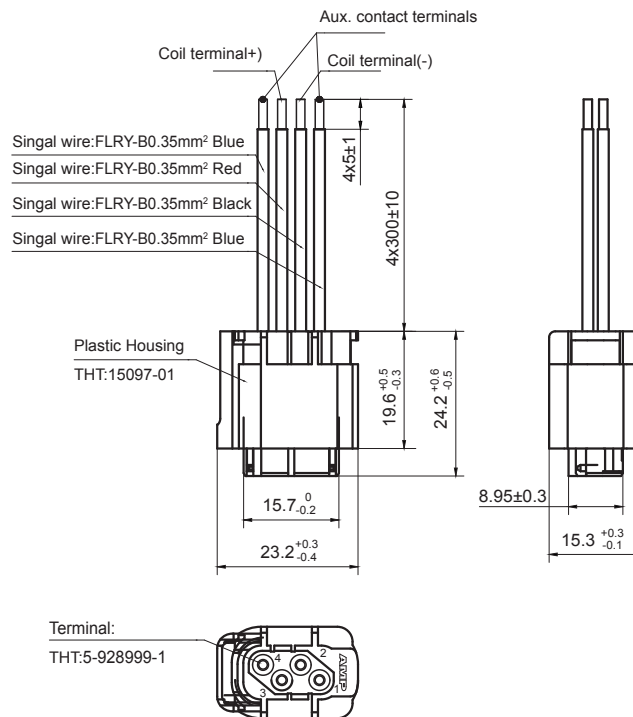

# CHARACTERISTIC CURVES

## Breaking Capability Curve (Resistive Load)

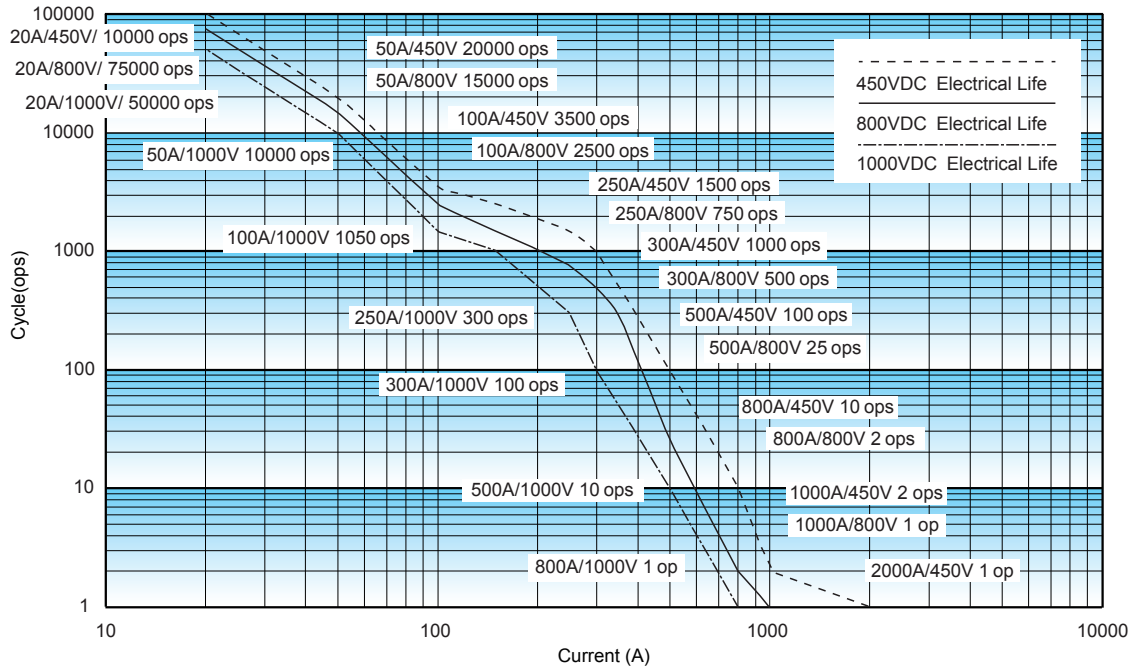

**Notes:**

1. The data is for reference only.
2. Conductor cross-sectional area  $\geq 100\text{mm}^2$ .
3. The data is measured under the resistive load ( $L/R \leq 1\text{ms}$ ), the duty cycle: 0.6s on: 5.4s off, ambient temperature:  $23^\circ\text{C}$ . The values may change according to the load type, duty cycle, and environmental conditions. therefore, it is recommended to confirm the values under actual load.
4. The curve is based on the standard relay measurement data. It is necessary to consider system voltage, electromagnetic compatibility of the copper busbar, the influence of installation stress when designing the system. If you have any questions, please contact hongfa technology team.

## Pick-up Voltage / Drop-out Voltage Curve

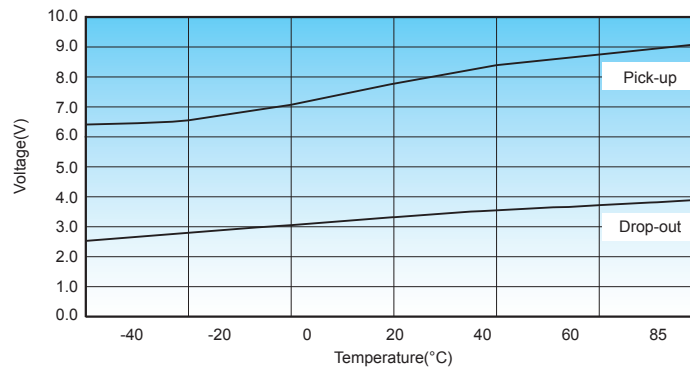

**Notes:**

1. The above values are sampling values for reference only.
2. The rated voltage of the sample coil is 12VDC.
3. The sampling ambient temperature is  $-40^\circ\text{C} \sim 85^\circ\text{C}$ .
4. The curve is based on the standard relay measurement data. It is necessary to consider system voltage, electromagnetic compatibility of the copper busbar, the influence of installation stress when designing the system. If you have any questions, please contact hongfa technology team.

## CHARACTERISTIC CURVES

Endurance Capacity Curve

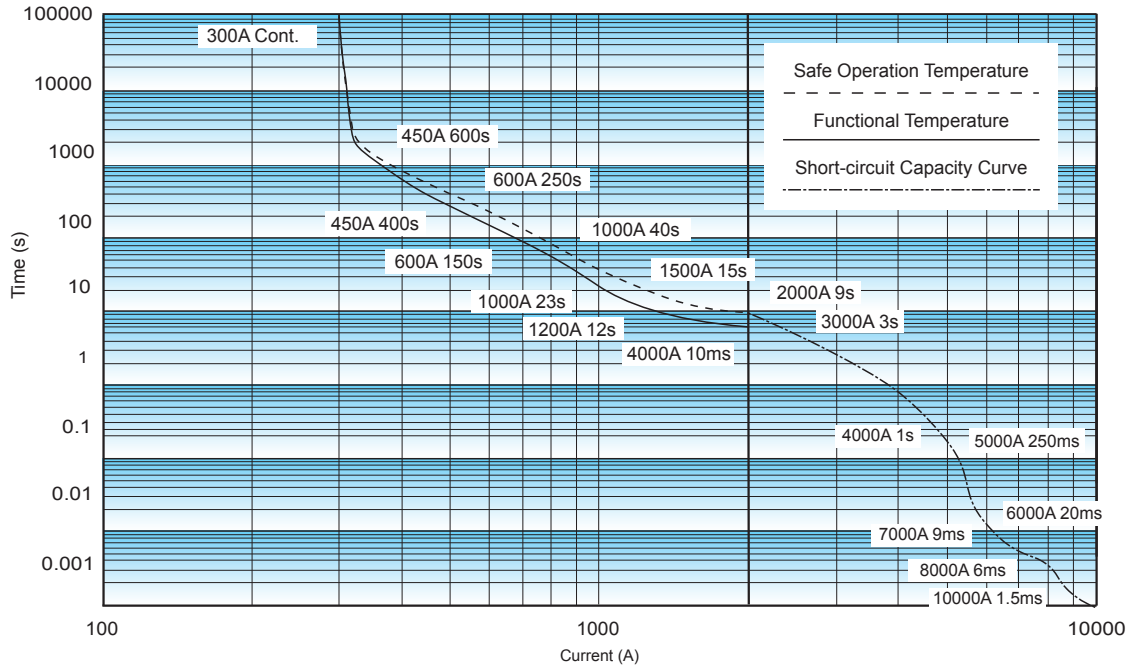

**Notes:**

1. The data is for design reference, it shall be verified as actual for model selection and fuse mating of short-circuit current test.
- 2.1. The upper limit of the safe operation temperature set by this curve is 180 °C, and the upper limit of the functional temperature is 130 °C; The long-term service temperature of the material is 130 °C, the short-term service temperature of the material after aging is 180 °C;
- 2.2. It is recommended that the upper temperature limit shall not exceed 130 °C when long time operation. It may also cause relay failure, if the safe temperature limit of 180 °C is exceeded;
- 2.3. There is a risk of fire and explosion in conditions beyond the safety curve. In case of similar conditions, the relay shall be replaced in time;
- 2.4. The ambient temperature is 85 °C for safe operation and function, and for current above 2000A, the temperature is room temperature with cross-sectional area  $\geq 100\text{mm}^2$ .
- 3.1. Even if it is below the safety curve when the current  $\geq 2000\text{A}$ , the relay is likely to be stuck during current carrying. If there is a break beyond the specification, fire and explosion may occur;
- 3.2. The contact is likely to bounce off when the current  $\geq 8000\text{A}$ . If the fuse cannot be fused in time, the relay may explode and may be ignited if the arc continues to burn after the explosion;
- 3.3. When the over-current is higher than 10000A, the levitation of contacts will possibly happen, and the circuit current cannot rise continuously. The relay may explode if the fuse blown cannot happen in time and fire may be caused if the arc continues after the explosion.
4. The curve is the measured data of standard relays. System voltage, electromagnetic compatibility and installation stress of copper busbar should be taken into consideration in system design. If any questions, please contact with our technical support for further consultation.

## CAUTIONS

1. In case of looseness, please use collars when mounting the relay. The torque beyond the range may cause damage.

Mounting for load terminal				Mounting for relay body	
Mounting way	Torque requirement	Hole dia. of copper bus bar	Thickness of copper bus bar	Mounting way	Torque requirement
M6 Screw	6N·m ~ 8N·m	Ø6.8mm~Ø7.2mm	4mm	M6 Screw	5N·m ~ 6N·m

- When use M6 screw, make sure the washer's thickness and strength are enough. Otherwise it will be out of shape, and the case will be broke.
- Please tighten the load terminal of relay vertically with preloading first when installing. Repeat locking is not recommended.
- If any special screws and nuts, such as nylok, are used when installing, it is recommended to contact and confirm with Hongfa.
- If any special installation requirements, such as a downward direction, multi busbar connection, are involved, it is recommended to contact and confirm with Hongfa.
- Please avoid adhering to foreign matter such as grease on the terminal lead end and please use the conductor with min. cross-sectional area of 100mm<sup>2</sup>, otherwise it may cause the abnormal heating of the terminal part.
- It is recommended that the copper busbar has a thickness of 4mm; otherwise, it will cause problems such as thread stripping or loose installation.
- Caution of mounting for relay body:

### Unrecommended method

Large opening of mounting plate at customer-side.

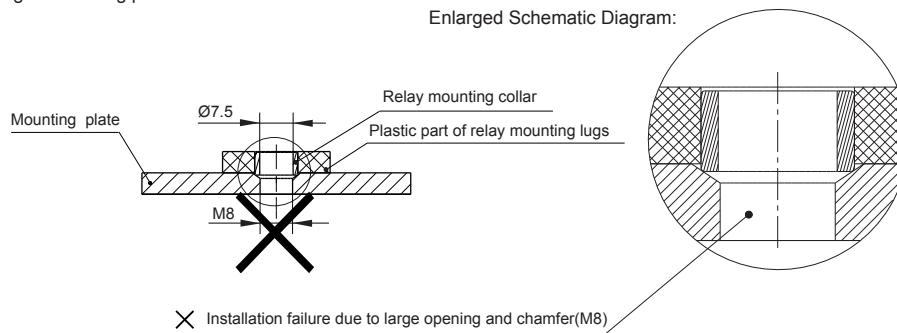

### Recommended method

Appropriate opening (M6) of mounting plate at customer-side.

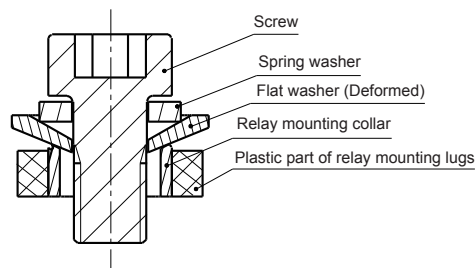
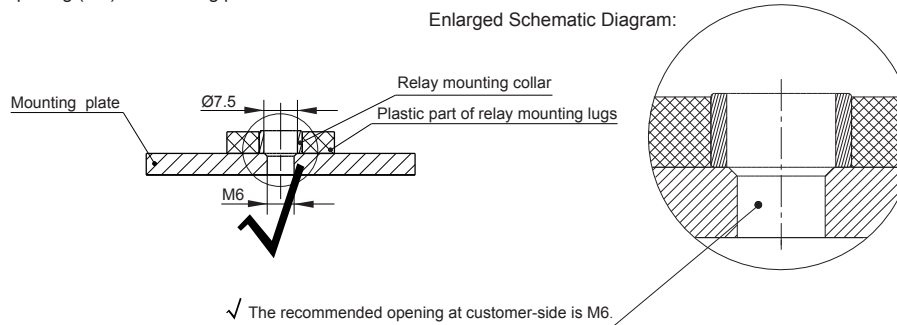

When use M6 screw, the thickness and strength of the washer needs to be guaranteed or it may deform and burst the cover.

### Disclaimer

The specification is for reference only. See to "Terminology and Guidelines" for more information. Specifications subject to change without notice. We could not evaluate all the performance and all the parameters for every possible application. Thus the user should be in a right position to choose the suitable product for their own application. If there is any query, please contact Hongfa for the technical service. However, it is the user's responsibility to determine which product should be used only.

© Xiamen Hongfa Electroacoustic Co.,Ltd. All rights of Hongfa are reserved.