

HFE91-200

HIGH POWER LATCHING RELAY



Features

- 200A Latching relay
- Electrical endurance up to 10,000ops
- 10kA r.m.s / 25ms short circuit current resistance
- Contact resistance $\leq 0.2m\Omega$

RoHS compliant

CONTACT DATA

Contact arrangement	2A, 2B
Contact resistance ¹⁾	Typical value: ²⁾ $\leq 0.2m\Omega(200A)$
Contact material	AgSnO ₂
Contact rating	200A 240VAC
Max. switching voltage	276VAC
Max. switching current	200A
Max. switching power	48000VA
Mechanical endurance	1 x 10 ⁵ ops
Electrical endurance	1 x 10 ⁴ ops

Notes:1) The data shown above are initial values.

2) Typical value: Sampling quantity for contact resistance shall not less than 20 pcs, take the average value from 5 continous measurements for each sample.

CHARACTERISTICS

Insulation resistance	1000M Ω (500VDC)	
Dielectric strength	Between coil and contact	4000VAC 1min
	Between open contacts	2000VAC 1min
Creepage distance	9.6mm	
Set time (at nomi. volt.)	$\leq 30ms$	
Reset time (at nomi. volt.)	$\leq 30ms$	
Shock resistance	Functional	98m/s ²
	Destructive	980m/s ²
Vibration resistance	10Hz ~ 55Hz 1.5mm DA	
Humidity	5% ~ 85% RH	
Ambient temperature	-40°C ~ 85°C	
Termination	Coil termination	PCB&QC
	Load termination	QC
Unit weight	Approx.400g	
Construction	Dust protected	

Notes: The data shown above are initial values.

COIL

Rated power	Single coil latching: Approx. 12W Double coils latching: Approx. 24W
-------------	---

COIL DATA

23°C

Single coil latching

Nominal Voltage VDC	Set / Reset Voltage VDC ¹⁾²⁾	Pulse Duration (Recommended) ms	Coil Resistance x (1 \pm 10%) Ω
6	≤ 4.8	50~100	3
9	≤ 7.2	50~100	6.75
12	≤ 9.6	50~100	12
24	≤ 19.2	50~100	48
48	≤ 38.4	50~100	190

Double coils latching

Nominal Voltage VDC	Set / Reset Voltage VDC ¹⁾²⁾	Pulse Duration (Recommended) ms	Coil Resistance x (1 \pm 10%) Ω
6	≤ 4.8	50~100	1.5+1.5
9	≤ 7.2	50~100	3.3+3.3
12	≤ 9.6	50~100	6+6
24	≤ 19.2	50~100	24+24
48	≤ 38.4	50~100	95+95

Notes:1) The data shown above are initial values.

2) The above values are used as incoming inspection standards, and the recommended driving voltage is 1~1.5 times of the rated voltage.



HONGFA RELAY

ISO9001, ISO/TS16949, ISO14001, OHSAS18001, IECQ QC 080000 CERTIFIED

2024 Rev.1.00

ORDERING INFORMATION

Type	HFE91-200 /12 -2D A 7 T -1 -R (XXX)						
Coil voltage	6,9,12,24,48VDC						
Contact arrangement ¹⁾	2D:2Form B 2H:2 Form A						
Auxiliary contact	Nil: No auxiliary contact A: Contact state is same as main contact B: Contact state is different from main contact						
Load terminal type	7: With customized extension connections Nil: Without customized extension connections						
Contact material	T: AgSnO ₂						
Coil type	1: Single coil 2: Double coils						
Polarity	R: Reverse polarity Nil: Standard polarity						
Special code ²⁾	A98: Without manual switch Nil: With manual switch						

Notes: 1) 2H means that relay is on the "reset" status when delivery; 2D means that relay is on the "set" status when delivery. If no special required by customer, we will keep the relay on the "set" status when delivery.
 2) The customer special requirement express as special code after evaluating by Hongfa.

OUTLINE DIMENSIONS, WIRING DIAGRAM AND PCB LAYOUT

Unit: mm

Outline Dimensions

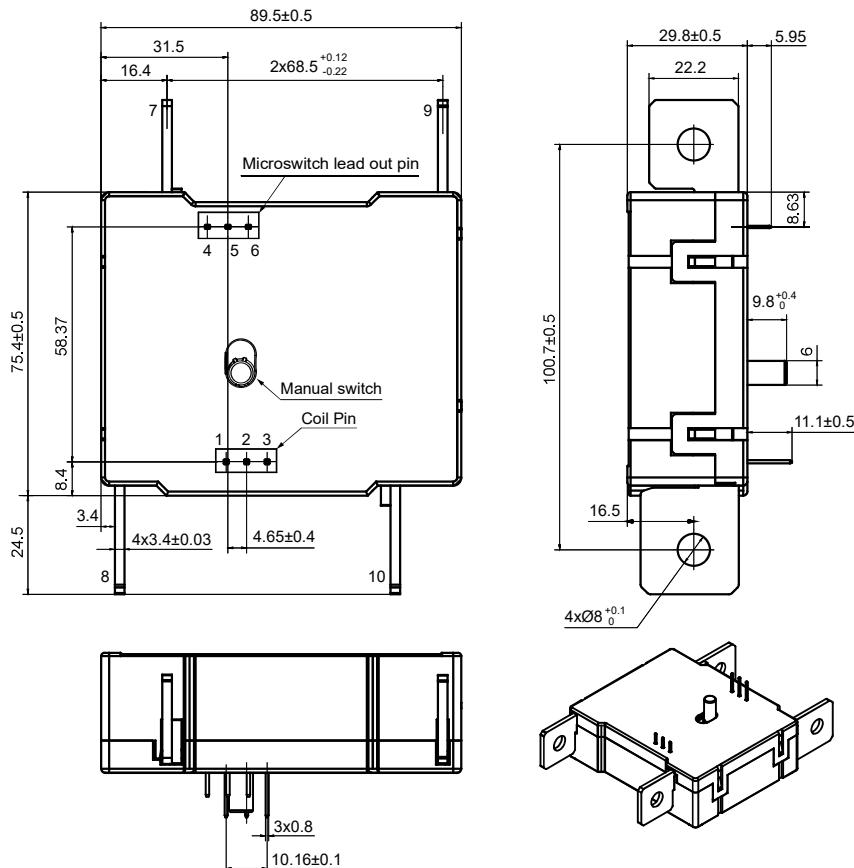

WIRING DIAGRAM

Standard polarity

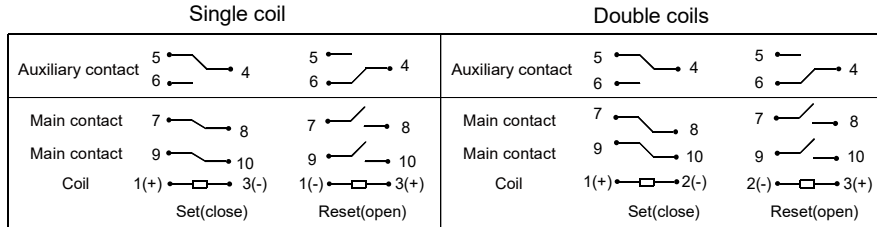

Negative polarity

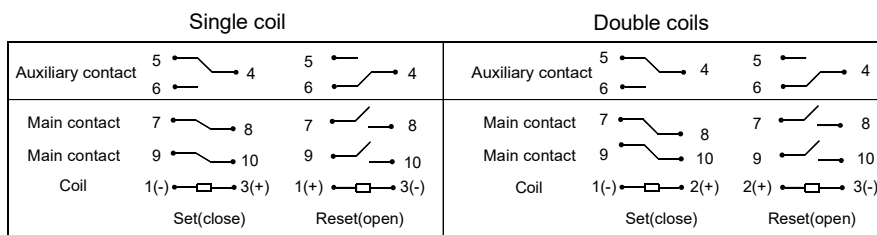

CAUTIONS

1. Relay is on the "reset" or "set" status when being released from stock, with the consideration of shock risen from transit and relay mounting, relay would be changed to "set" or "reset" status, therefore, when application (connecting the power supply), please reset the relay to "set" or "reset" status on request.
2. Do not energize voltage to "set" coil and "reset" coil simultaneously. And also long energized time (more than 1 min) should be avoided.
3. Normally the load terminals are not suitable for reflow solder, wave solder or tin solder, we suggest use spot welding. Load terminals shall be prevented from assembly stress, or freely move.
4. Relays used for metering measuring applications are usually made with dust proof structure, while most relays could be made specially per customer's specific requirements. No longer than 6 months' storage time is recommended for this kind of relay, and please pay attention to the storage environment. To ensure contact reliability, we will keep contact status be closed when delivery if no special required by customer.

Disclaimer

The specification is for reference only. Specifications subject to change without notice. We could not evaluate all the performance and all the parameters for every possible application. Thus the user should be in a right position to choose the suitable product for their own application. If there is any query, please contact Hongfa for the technical service. However, it is the user's responsibility to determine which product should be used only.