

HFE19(SH) MINIATURE HIGH POWER LATCHING RELAY

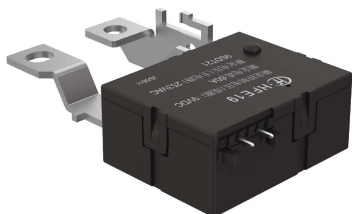

Features

- 90A Latching relay
- Electrical endurance 10000ops
- According to IEC62055-31:UC2
- Contact resistance $\leq 0.45\text{m}\Omega$

RoHS compliant

CONTACT DATA

Contact arrangement	1A(Dual contact),1B(Dual contact)
Contact resistance ¹⁾	Typical value: ²⁾ $\leq 0.45\text{m}\Omega(60\text{A})$
Contact material	AgSnO ₂
Contact rating	See "electrical endurance"
Max. switching voltage	276VAC
Max. switching current	90A
Max. switching power	24840W
Mechanical endurance	1x10 ⁵ ops

Notes: 1) The data shown above are initial values.

2) Typical value: Sampling quantity for contact resistance shall not less than 20 pcs, take the average value from 5 continuous measurements for each sample.

CHARACTERISTICS

Insulation resistance	1000M Ω (500VDC)	
Dielectric strength	Between coil and contact	4000VAC 1min
	Between open contacts	2000VAC 1min
Creepage distance	8mm	
Set time (at nomi. volt.)	$\leq 20\text{ms}$	
Reset time (at nomi. volt.)	$\leq 20\text{ms}$	
Shock resistance	Functional	98m/s ²
	Destructive	980m/s ²
Vibration resistance	10Hz ~ 55Hz 1.5mm DA	
Humidity	5% ~ 85% RH	
Ambient temperature	-40°C ~ 85°C	
Termination	Coil termination	PCB&QC
	Load termination	QC
Unit weight	Approx. 100g	
Construction	Dust protected	

Notes: The data shown above are initial values.

COIL

Rated power	Single coil latching: Approx. 1.5W Double coils latching: Approx. 3W
-------------	---

COIL DATA

23°C

Single coil latching

Nominal Voltage VDC	Set / Reset Voltage VDC ^{1,2)}	Pulse Duration (Recommended) ms	Coil Resistance x (1 \pm 10%) Ω
6	≤ 4.2	50~100	24
9	≤ 6.3	50~100	54
12	≤ 8.4	50~100	96
24	≤ 16.8	50~100	384
48	≤ 33.6	50~100	1536

Double coils latching

Nominal Voltage VDC	Set / Reset Voltage VDC ^{1,2)}	Pulse Duration (Recommended) ms	Coil Resistance x (1 \pm 10%) Ω
6	≤ 4.2	50~100	12+12
9	≤ 6.3	50~100	27+27
12	≤ 8.4	50~100	48+48
24	≤ 16.8	50~100	192+192
48	≤ 33.6	50~100	768+768

Notes: 1) The data shown above are initial values.

2) The above values are used as incoming inspection standards, and the recommended driving voltage is 1~1.5 times of the rated voltage.

ELECTRICAL ENDURANCE

Voltage (Uc)	Current (Ic)	Power Factor	Close Open time (s)	Electrical endurance (ops)	
253VAC	60A	COS ϕ =1	10:20	5000	Total:10000
		COS ϕ =0.5		5000	

Notes: 1) Electrical endurance meet IEC62055-31 test requirement, do the inductive load test after the resistive load test.

2) Only some typical ratings of UC are listed above, if more special ratings required, please contact us.



HONGFA RELAY

ISO9001、IATF16949、ISO14001、ISO45001、IECQ QC 080000、ISO/EC 27001

2025 Rev.1.00

ORDERING INFORMATION

Type		HFE19 -90/ 12 SD T 2 1 -R (XXX)							
Contact rating	90: 90A								
Coil voltage	6, 9, 12, 24, 48VDC								
Contact arrangement	1) SD: 1 Form B (Dual contact) SH: 1 Form A (Dual contact)								
Contact material	T: AgSnO ₂								
Coil angle form	2: Distance 5mm; No bowleg 4: Distance 5mm; L-bowleg								
Coil type	1: Single coil latching 2: Double coils latching								
Polarity	R: Reverse polarity Nil: Standard polarity								
Special code	2) XXX: Customer special requirement								

Notes: 1) SH means that relay is on the "reset" status when delivery; SD means that relay is on the "set" status when delivery. If no special required by customer, we will keep the relay on the "set" status when delivery.
2) The customer special requirement express as special code after evaluating by Hongfa.

OUTLINE DIMENSIONS, WIRING DIAGRAM AND PCB LAYOUT

Unit: mm

Outline Dimensions

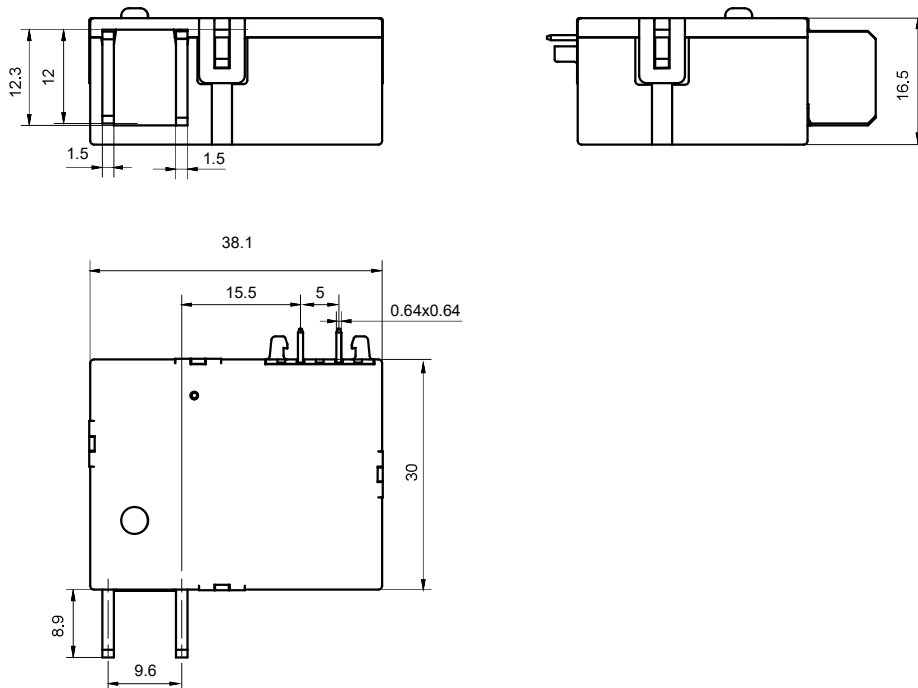

Wiring Diagram

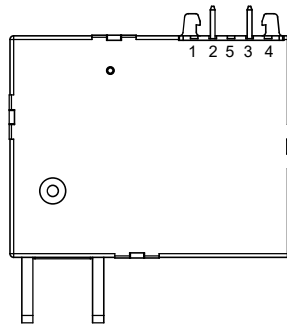

Standard polarity

Reverse polarity

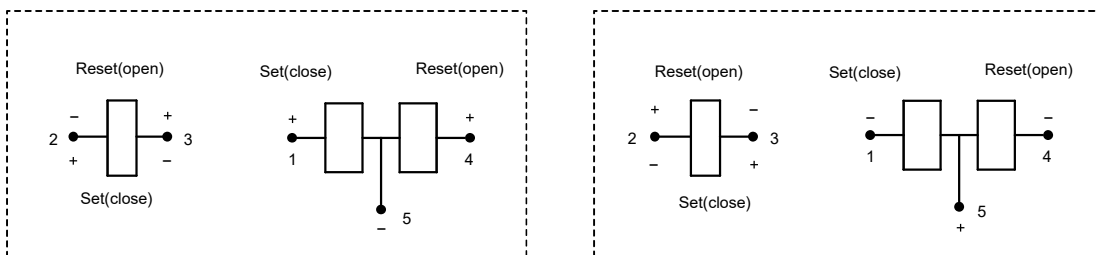

Typical Design

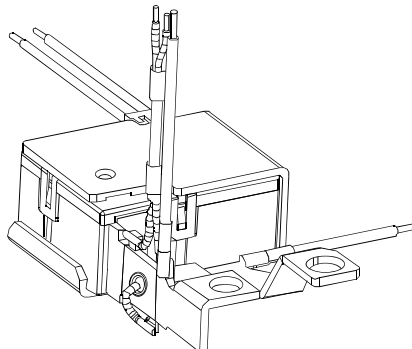

Remark: The drawing shown above are typical design, we can make special design according to customer's requirement. Please provide us with the drawing.

CAUTIONS

1. Relay is on the "reset" or "set" status when being released from stock, with the consideration of shock risen from transit and relay mounting, relay would be changed to "set" or "reset" status, therefore, when application (connecting the power supply), please reset the relay to "set" or "reset" status on request.
2. Do not energize voltage to "set" coil and "reset" coil simultaneously. And also long energized time (more than 1 min) should be avoided.
3. Normally the load terminals are not suitable for reflow solder, wave solder or tin solder, we suggest use spot welding. Load terminals shall be prevented from assembly stress, or freely move.
4. Relays used for metering measuring applications are usually made with dust proof structure, while most relays could be made specially per customer's specific requirements. No longer than 6 months' storage time is recommended for this kind of relay, and please pay attention to the storage environment. To ensure contact reliability, we will keep contact status be closed when delivery if no special required by customer.

Disclaimer

The specification is for reference only. Specifications subject to change without notice. We could not evaluate all the performance and all the parameters for every possible application. Thus the user should be in a right position to choose the suitable product for their own application. If there is any query, please contact Hongfa for the technical service. However, it is the user's responsibility to determine which product should be used only.

©Xiamen Hongfa Electroacoustic Co., Ltd. All rights of Hongfa are reserved.