

HF56F

MINIATURE HIGH POWER RELAY



File No.:E133481



File No.:R 50597724



File No.:CQC23002406643



Features

- 20A switching capability
- Small size, width only 7mm
- Meet IEC62368-1 requirements
- 8kV surge voltage (between coil and contact)
- Air gap/creepage distance > 8mm
- Meet the requirements for enhanced insulation
- Class F insulation system

RoHS compliant

CONTACT DATA

Contact arrangement	1A
Contact resistance	Max.100mΩ(1A 6VDC)
Contact material	AgSnO ₂
Contact rating (resistance)	Making 5A Carrying 20A Breaking 5A 277 VAC
Max.switching voltage	277VAC
Max.switching current	20A
Max.switching power	5540VA
Mechanical endurance	1×10 ⁶ ops
Electrical endurance	1×10 ⁵ ops (85°C, Making 5A carrying 20A breaking 5 A, 277VAC, Resistive load, 1s on 9s off) 1×10 ⁴ ops (85°C, 20A, 277VAC, Resistive load, 1s on 9s off)

Notes:1) The data shown above are initial values.
2) Sealed type electrical endurance test with open hole.

CHARACTERISTICS

Insulation resistance	1000MΩ(500VDC)	
Dielectric strength	Between open contacts	1000VAC 1min
	Between coil & contacts	4000VAC 1min
Surge Voltage(Between coil & contacts)	8kV(1.2/50μs)	
Operate time (at nomi. volt.)	10ms max.	
Release time (at nomi. volt.)	10ms max.	
Shock resistance	Functional	98m/s ²
	Destructive	980m/s ²
Vibration resistance	10Hz to 55Hz 1.5mm DA	
Humidity	5% to 85%RH	
Ambient temperature	-40°C to 85°C	
Termination	PCB	
Unit weight	Approx. 6g	
Construction	Plastic sealed,flux proofed	

Notes:The data shown above are initial values.

COIL

Coil power	Standard:Approx. 0.8W
Holding voltage	Applied voltage of coil 100% rated voltage for 100 ms holding voltage of coil 60% ~ 70% rated voltage, at 85°C

Notes:1) To avoid overheating and burning, the coil can not be consistently applied to with voltage larger than maximum holding voltage.

COIL DATA

23°C

Nominal Voltage VDC	Pick-up Voltage VDC max.	Drop-out Voltage VDC min.	Max. Allowable Voltage VDC ¹⁾	Coil Resistance Ω
6	4.50	0.30	7.8	45×(1±10%)
9	6.75	0.45	11.7	101×(1±10%)
12	9.00	0.60	15.6	180×(1±10%)
18	13.5	0.90	23.4	405×(1±10%)
24	18.0	1.20	31.2	720×(1±10%)

Notes:1) Maximum voltage refers to the maximum voltage which relay coil could endure in a short period of time.

SAFETY APPROVAL RATINGS

UL/CUL	Making 5 A carrying 20 A breaking 5 A, 277VAC, Resistive 85°C 20 A, 277VAC, Resistive 85°C
TÜV	Making 5 A carrying 20 A breaking 5 A, 277VAC, Resistive 85°C 20 A, 277VAC, Resistive 85°C

Notes:1) All values unspecified are at room temperature.
2)Only some typical rating are listed above.If more details are required,please contact us.



HONGFA RELAY

ISO9001, IATF16949, ISO14001, ISO45001, IECQ QC 080000, ISO/IEC 27001 CERTIFIED

2026 Rev. 1.00

ORDERING INFORMATION

Type	HF56F	12	-H	S	T	F	(XXX)
Coil voltage	6,9,12,18,24VDC						
Contact arrangement	H:1 Form A						
Construction	S: Plastic sealed Nil: Flux proofed						
Contact material	T: AgSnO ₂						
Insulation standard	F: Class F						
Special code	XXX: Customer special requiremen Nil: Standard						

Notes: 1) Flux-proofed relays can not be used in the environment with pollutants like H₂S, SO₂, NO₂, dust, etc..
 2) Water cleaning or surface process is not suggested after the flux-proofed relays are assembled on PCB.
 3) The customer special requirement express as special code after evaluating by Hongfa.e.g.

OUTLINE DIMENSIONS, WIRING DIAGRAM AND PC BOARD LAYOUT

Unit: mm

Outline Dimensions

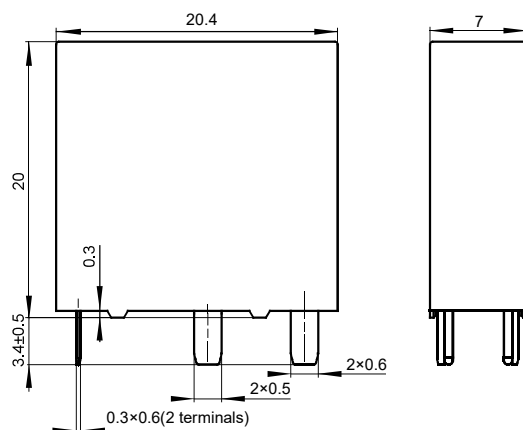

PCB Layout(Bottom view)

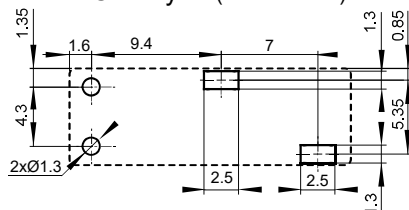

Wiring Diagram(Bottom view)

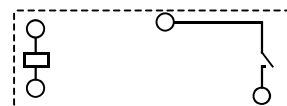

Notes: 1) The pin dimension of the product outline drawing is the size before tinning(it will become larger after tinning),and the mounting hole size is the recommended design size of the PCB board hole.The specific PCB board hole design size can be mapped and adjusted according to the actual product.
 2) In case of no tolerance shown in outline dimension: outline dimension ≤ 1 mm, tolerance should be ± 0.2 mm;
 outline dimension > 1 mm and ≤ 5 mm,tolerance should be ± 0.3 mm; outline dimension > 5 mm, tolerance should be ± 0.4 mm.
 3) The tolerance without indicating for PCB layout is always ± 0.1 mm.
 4) The cross section dimension of rectangular terminal is marked as "a×b", where "a" is the dimension of the side shown in the current view.

Disclaimer

The specification is for reference only. See to "Terminology and Guidelines" for more information. Specifications subject to change without notice. We could not evaluate all the performance and all the parameters for every possible application. Thus the user should be in a right position to choose the suitable product for their own application. If there is any query, please contact Hongfa for the technical service. However, it is the user's responsibility to determine which product should be used only.

© Xiamen Hongfa Electroacoustic Co., Ltd. All rights of Hongfa are reserved.