

HFE82V-150D(A10)

DIRECT CURRENT RELAY



File No.:E133481



File No.:R50581511



File No.:AN50581529



Features

- Hermetically sealed with ceramic brazing technology, without risk of arc leaking, no fire or explosion.
- Filled with hydrogen gas to prevent the oxidation and burnout of contacts; Low and stable contact resistance, with IP67 compliant.
- 150A continuous carry current capability at 85°C.
- Max. insulation resistance up to 1000MΩ (@1000 VDC), dielectric strength (coil-contact) up to 4kV, IEC 60664-1 compliant.

RoHS compliant

CONTACT DATA

Contact arrangement	1 Form A
Contact resistance 1)	≤0.3mΩ(150A)
Contact rating	150A
Mechanical endurance	2x10 ⁵ ops
Max. switching voltage	1000 VDC
Max. breaking current	1200A(300 VDC) 1 op
Max. switching power	225kW

	Type 450V	Type 750V
Electrical endurance 2)	Making:2.5x10 ⁴ ops (22.5VDC, τ =1ms, Inrush 400A, Steady150A)	Making:1x10 ⁴ ops (37.5 VDC, τ =1ms, Inrush 400A, Steady150A)
	Switching:1x10 ³ ops (450 VDC, 150A)	Switching:100 ops (750 VDC,150A)
	Switching:3x10 ³ ops (200 VDC, 120A)	
	Switching:1 ops (300 VDC, 1200A)	

Electrical endurance 2)	Type 1000V	
	Switching:100 ops(800V, 150A)	
	Switching:50 ops(1000V, 150A)	
	Breaking:100 ops(1000V, 150A)	

Current carrying 3) capacity	150A: Cont.
	180A: 2h
	225A: 15min
	320A: 2min
	400A: 60s
	600A: 20s
900A: 8s	

- Notes:** 1) The above values are the initial values.
 2) Unless otherwise specified, the temperature of electrical endurance is at 23°C and the on-off ratio is 0.6s:5.4s.
 The coil was not connected to the surge suppression device during the test. Please note that the use of a well-connected diode will greatly increase the release time of the relay, resulting in a reduced lifetime.
 3) Ambient temperature is at 85°C and cross section area of wire is 50mm² min. See Fig. Endurance Capacity Curve for more information.

COIL

23°C

Rated Voltage VDC	Pick-up Voltage VDC	Drop-out Voltage VDC	Coil power W
12	≤9	≥1	5.5
24	≤18	≥2	5.5

CHARACTERISTICS

Insulation resistance		1000MΩ(1000 VDC)
Dielectric strength	Between coil & contacts	4000 VAC 1min
	Between open contacts	3000 VAC 1min
Operate time (at rated volt.)		≤30ms
Release time (at rated volt.)		≤10ms
Shock resistance	Functional	196m/s ²
	Destructive	490m/s ²
Vibration resistance		10Hz ~ 500Hz 49m/s ²
Humidity		5% ~ 85% RH
Ambient temperature		-40°C ~ 85°C
Load terminal structure		Screw terminal female
Unit weight		Approx.260g
Outline Dimensions		78.7 x 36.0 x 72.0mm

Notes:The above values are the initial values measured at room temperature.

SAFETY APPROVAL RATINGS

UL/CUL	Resistive Marking:1500VDC/30A 11000 ops 40°C
	Resistive Breaking: 1000VDC/20A 6000 ops 40°C
	Resistive Switching: 1500VDC/5A 6000 ops 40°C
TÜV	DC-1: 1000VDC/5A 6000 ops 40°C
	Resistive Breaking: 1000VDC/20A 6000 ops 40°C
	Resistive Marking:1500VDC/30A 6000 ops 40°C
CE	DC-1: 1000VDC/5A 6000 ops 40°C
	Resistive Breaking: 1000VDC/20A 6000 ops 40°C
	Resistive Marking:1500VDC/30A 6000 ops 40°C

Notes:1) The load without temperature specified in the table refers to the ambient temperature being room temperature.

2) The above only lists some typical loads certified for this product. The electrical durability varies due to the different detailed testing conditions for each load. If you need more information, please contact us.



HONGFA RELAY

ISO9001, IATF16949, ISO14001, ISO45001, IECQ QC 080000, ISO/EC 27001 CERTIFIED

2025 Rev.1.00

ORDERING INFORMATION

Type	HFE82	V	-150	D/	750-	12-	H	C	5	(A10)
Application	V: Vehicle									
Contact rating	150: 150A									
Series breakdown	D: D series									
Load voltage	Nil: 450 VDC 750: 750 VDC 1000: 1000 VDC									
Coil voltage	12: 12 VDC 24: 24 VDC									
Contact arrangement	H: 1 Form A									
Coil terminal structure	C: Connector									
Load terminal structure	5: Screw terminal female									
Special code ¹⁾	(A10): Standard (A10)(XXX): XXX: Customer special requirement									

Notes: 1) The customer special requirement express as special code after evaluating by Hongfa.

OUTLINE DIMENSIONS, MOUNTING HOLE, TERMINAL ARRANGEMENT

Unit: mm

Outline Dimensions

HFE82V-150D/XXX-XX-HC5(A10)

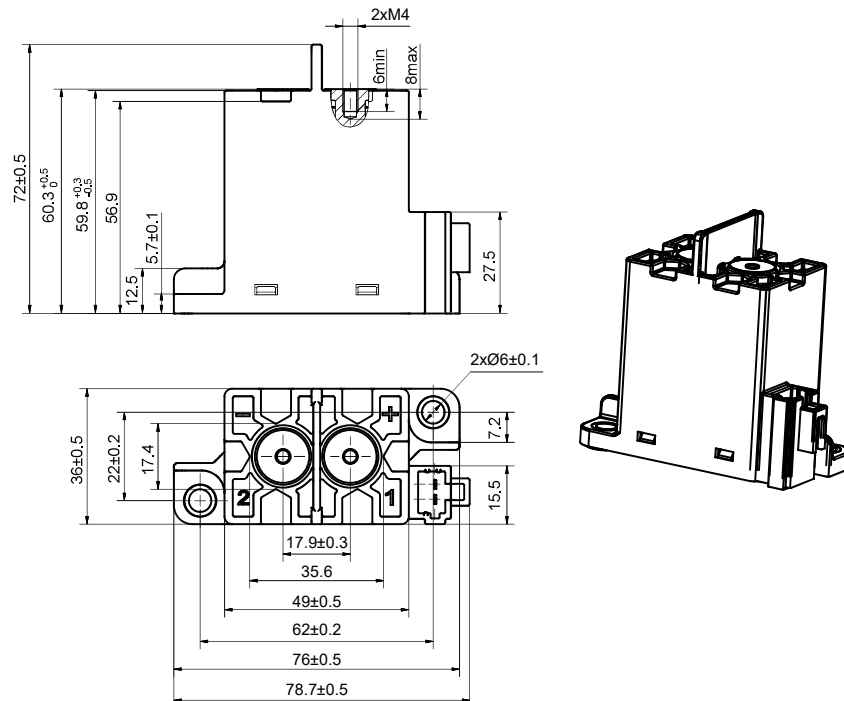

Notes: In case of no tolerance shown in outline dimension: outline dimension $\leq 10 \text{mm}$, tolerance should be $\pm 0.3 \text{mm}$; outline dimension $> 10 \text{mm}$ and $\leq 50 \text{mm}$, tolerance should be $\pm 0.5 \text{mm}$; outline dimension $> 50 \text{mm}$, tolerance should be $\pm 0.8 \text{mm}$.

OUTLINE DIMENSIONS, MOUNTING HOLE, TERMINAL ARRANGEMENT

Unit: mm

Outline Dimensions

HFE82V-150D/XXX-XX-HC5(A10)(A70)

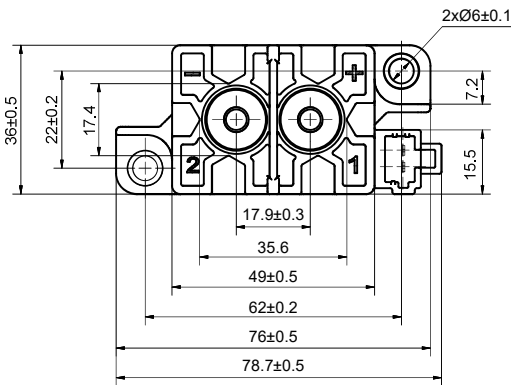
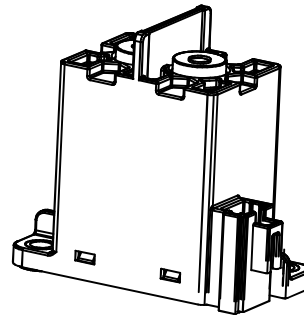
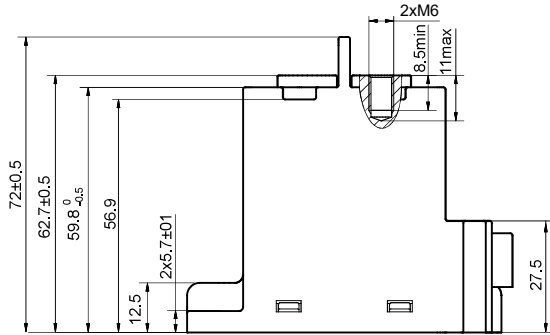

Mounting Hole

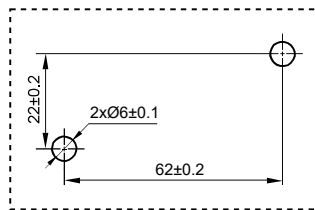

Terminal Arrangement

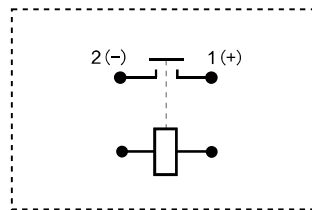

Notes: The load side has polarity.
No polarity on the coil side.

WIRING DIAGRAM

Unit: mm

C:Connector

(Configured by customers:THB 0435 series, Yazaki 7283-1020)

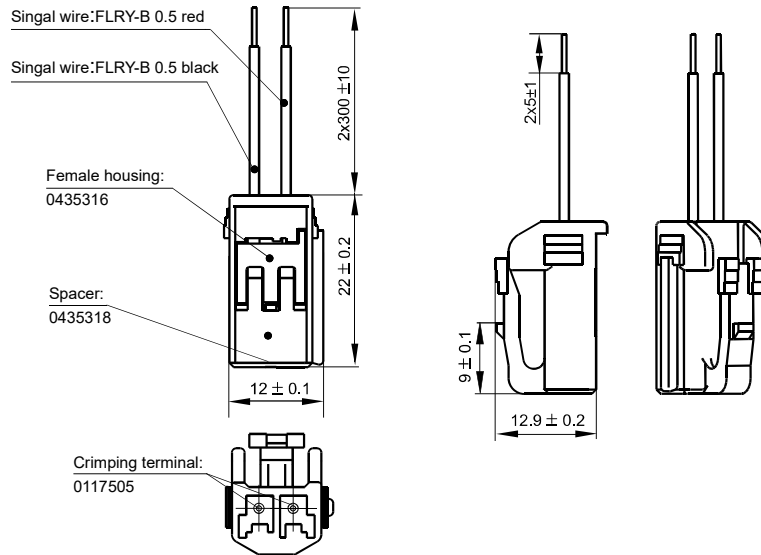

CHARACTERISTIC CURVES

Breaking Capability Curve (Resistive Load)

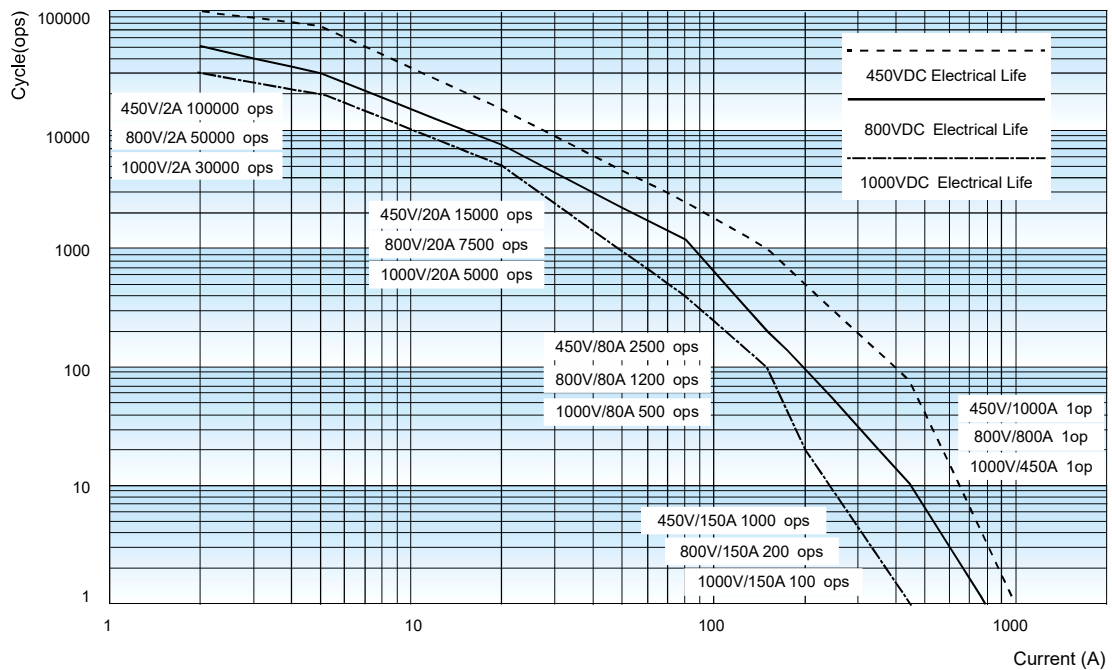

Notes:

- 1) The data is for reference only.
- 2) Cable cross section: $\geq 50\text{mm}^2$.
- 3) The data is measured under the resistive load ($L/R \leq 1\text{ms}$), the duty cycle: 0.6s on: 5.4s off, ambient temperature: 23°C ;
The values may change according to the load type, duty cycle, and environmental conditions. therefore, it is recommended to confirm the values under actual load.

CHARACTERISTIC CURVES

Endurance Capacity Curve

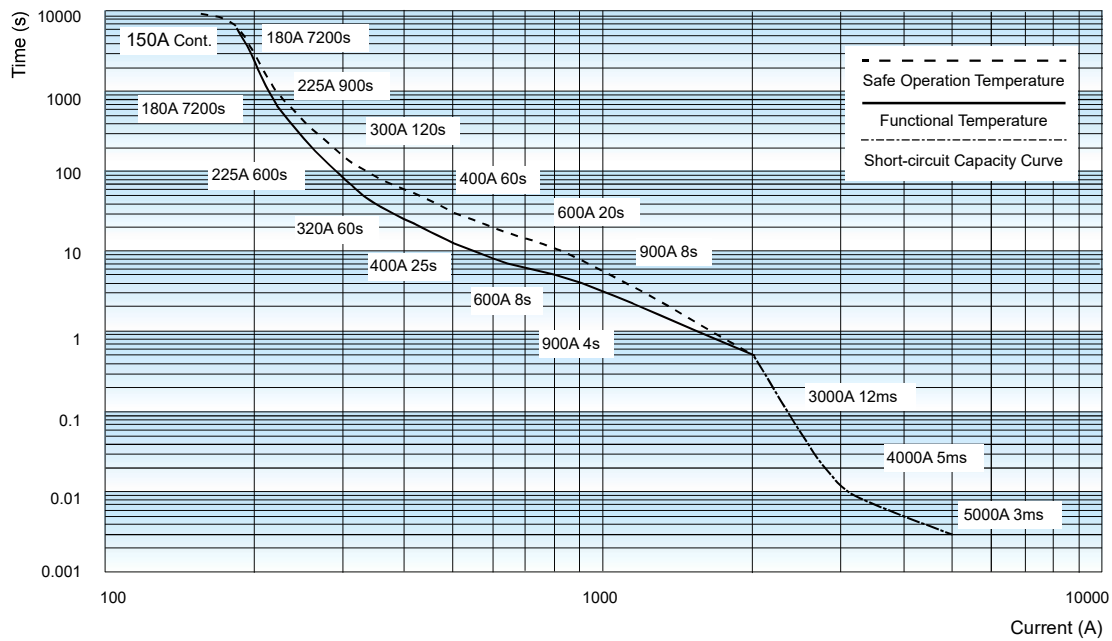

Notes:

- 1) The data is for design reference, it shall be verified as actual for model selection and fuse mating of short-circuit current test.
- 2) The upper temperature limit of safe operation and function are set for 180°C and 130°C respectively.
- 3) It is recommended that the upper temperature limit shall not exceed 130°C when long time operation. The relay may also fail, if the safe temperature limit of 180°C is exceeded.
- 4) Risks of fire and explosion may exist when the working condition beyond the safe circuit curve. in case of similar working condition, the relay shall be replaced in time.
- 5) The ambient temperature is 85°C for safe operation and function, and for current above 2000A, the temperature is room temperature with cross-sectional area $\geq 50\text{mm}^2$.
- 6) Even if it is below the safety curve when the current $\geq 2000\text{A}$, the relay is likely to be bonded during current carrying. If there is a break beyond the specification, fire and explosion may occur.
- 7) The contact is likely to bounce off when the current $\geq 3000\text{A}$. If the fuse cannot be fused in time, the relay may explode and may be ignited if the arc continues to burn after the explosion.
- 8) The contact will severely bounce off when the current $\geq 5000\text{A}$ which may cause the circuit current cannot continue to rise. If the fuse cannot be fused in time, the relay may explode and the arc may ignite the relay after the explosion.

Pick-up Voltage / Drop-out Voltage Curve

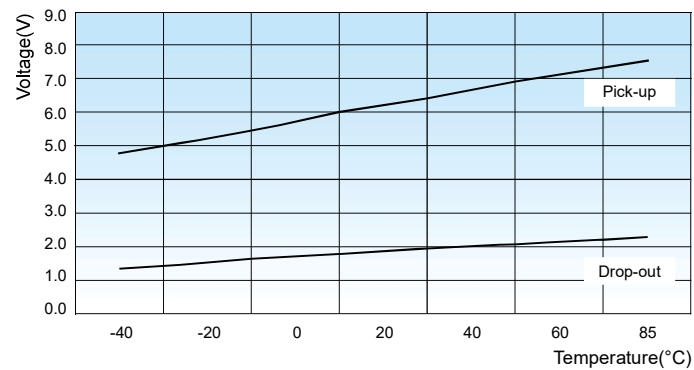

- Notes:**
- 1) The above values are sampling values for reference only;
 - 2) The rated voltage of the sample coil is 12VDC;
 - 3) The sampling ambient temperature is -40°C ~ 85°C.

CAUTIONS

- In case of looseness, please use washer when install the relay with M5 screw, and the torque within 3N·m to 4N·m, The torque beyond the range may cause damage.

Mounting for load terminal				Mounting for relay body	
Mounting way	Torque requirement	Hole dia. of copper bus bar	Thickness of copper bus bar	Mounting way	Torque requirement
M4 Screw	2N·m ~ 3N·m	Ø4.0mm ~ Ø4.5mm	2mm ~ 3mm	M5 Screw	3N·m ~ 4N·m
M6 Screw	6N·m ~ 8N·m	Ø6.0mm ~ Ø6.5mm	2mm ~ 3mm	M5 Screw	3N·m ~ 4N·m

- Please tighten the load terminal of relay vertically with preloading first when installing. Repeat locking is not recommended.
- If any special screws and nuts, such as nylok, are used when installing, it is recommended to contact and confirm with Hongfa.
- If any special installation requirements, such as downward direction, multi busbar connection, are involved, it is recommended to contact and confirm with Hongfa.
- Please avoid adhering to foreign matter such as grease on the terminal lead end and please use the conductor with min. cross section area of 50mm², otherwise it may cause the abnormal heating of the terminal part.
6. Cautions of mounting for relay body:

Unrecommended method

Large opening of mounting plate at customer-side.

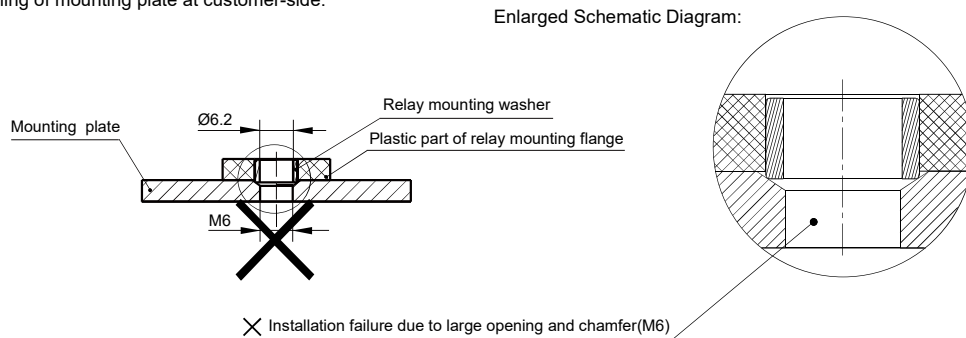

Recommended method

Appropriate opening (M5) of mounting plate at customer-side.

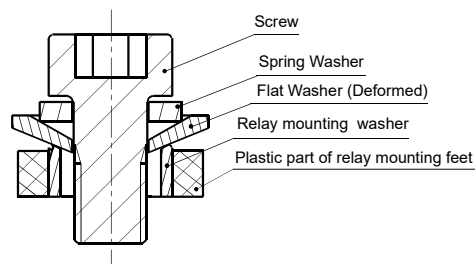
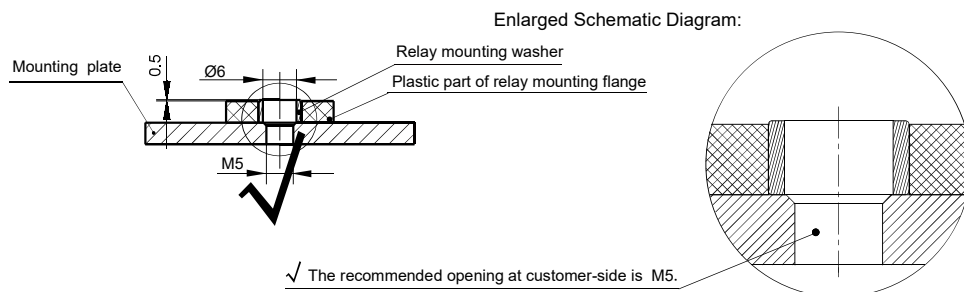

When use M5 screw, the thickness and strength of the washer needs to be guaranteed or it may deform and burst the cover.

Disclaimer

The specification is for reference only. See to "Terminology and Guidelines" for more information. Specifications subject to change without notice. We could not evaluate all the performance and all the parameters for every possible application. Thus the user should be in a right position to choose the suitable product for their own application. If there is any query, please contact Hongfa for the technical service. However, it is the user's responsibility to determine which product should be used only.

© Xiamen Hongfa Electroacoustic Co.,Ltd. All rights of Hongfa are reserved.