

HFE82V-300E

DIRECT CURRENT RELAY



RoHS compliant

Features

- Hermetically sealed with ceramic brazing technology, without risk of arc leaking, no fire or explosion.
- Filled with hydrogen gas to prevent the oxidation and burnout of contacts; Low and stable contact resistance, with IP67 compliant.
- 300A continuous carry current capability at 85°C.
- Max. insulation resistance up to 1000MΩ (@1000 VDC), dielectric strength (coil-contact) up to 3kV, IEC 60664-1 compliant.

CONTACT DATA

Contact arrangement	1 Form A	
Contact resistance ¹⁾	≤0.2mΩ(300A)	
Contact rating	300A	
Mechanical endurance	2 x 10 ⁶ ops	
Max. switching voltage	1000 VDC	
Max. breaking current	1400A (1000VDC) 1op	
Max. switching power	300kW	
	Type 450V	Type 750V
Electrical endurance ²⁾	Making: 7.5×10 ⁴ ops (20VDC 140A)	Breaking: 200 ops (750VDC 300A)
	Breaking: 500ops (450VDC 300A)	
	Breaking:1op (450VDC 3500A)	
	Type 1000V	
Electrical endurance ²⁾	Breaking:1 op(1000VDC 1400A)	
Current carrying ³⁾ capacity	300A:Cont.	
	450A 300s	
	600A 120s	
	900A 30s	
	1000A 25s	

Notes: 1) The above values are the initial values.

2) Unless otherwise specified, the temperature of electrical endurance is at 23°C and the on-off ratio is 0.6s:5.4s.

The coil was not connected to the surge suppression device during the test. Please note that the use of a well-connected diode will greatly increase the release time of the relay, resulting in a reduced lifetime.

3) Ambient temperature is at 85°C and cross section area of wire is 100mm² min. See Fig. Endurance Capacity Curve for more information.

COIL

23°C

Rated Voltage VDC	Pick-up Voltage VDC	Drop-out Voltage VDC	Coil power W
12	≤9	≥1	6
24	≤18	≥2	6

CHARACTERISTICS

Insulation resistance		1000MΩ(1000 VDC)
Dielectric strength	Between coil & contacts	3000 VAC 1min
	Between open contacts	3000 VAC 1min
Operate time (at rated volt.)		≤30ms
Release time (at rated volt.)		≤10ms
Shock resistance	Functional	Deenergized:147 m/s ² Energized:196 m/s ²
	Destructive	588m/s ²
Vibration resistance		10Hz ~ 500Hz 49m/s ²
Humidity		5% ~ 85% RH
Ambient temperature		-40°C ~ 85°C
Load terminal structure		M6 screw terminal female
Unit weight		Approx.385g
Outline Dimensions		88.3x42.5x74.5mm(HC5) 85.1x42.5x74.5mm(HC5Y)

Notes:The above values are the initial values measured at room temperature.



HONGFA RELAY

ISO9001、IATF16949、ISO14001、ISO45001、IECQ QC 080000、ISO/EC 27001

2024 Rev.1.00

ORDERING INFORMATION

	HFE82	V	-300	E/	750-	12-	H-	C	5	Y	-1	(XXX)
Type												
Application	V: Vehicle											
Contact rating	300: 300A											
Series breakdown	E: E series											
Load voltage	Nil:450VDC 750:750VDC 1000:1000VDC											
Coil voltage	12: 12 VDC 24: 24 VDC											
Contact arrangement	H: 1 Form A											
Coil terminal structure	C: Connector											
Load terminal structure	5: Screw terminal female											
Mounting	Nil: Vertical mounting Y: Horizontal mounting											
Coil characteristic	1: Single coil											
Special code¹⁾	XXX: Customer special requirement											

Notes: 1) The customer special requirement express as special code after evaluating by Hongfa.

OUTLINE DIMENSIONS, MOUNTING HOLE, TERMINAL ARRANGEMENT

Unit: mm

Outline Dimensions

HFE82V-300C/XXX-XX-H-C5-1

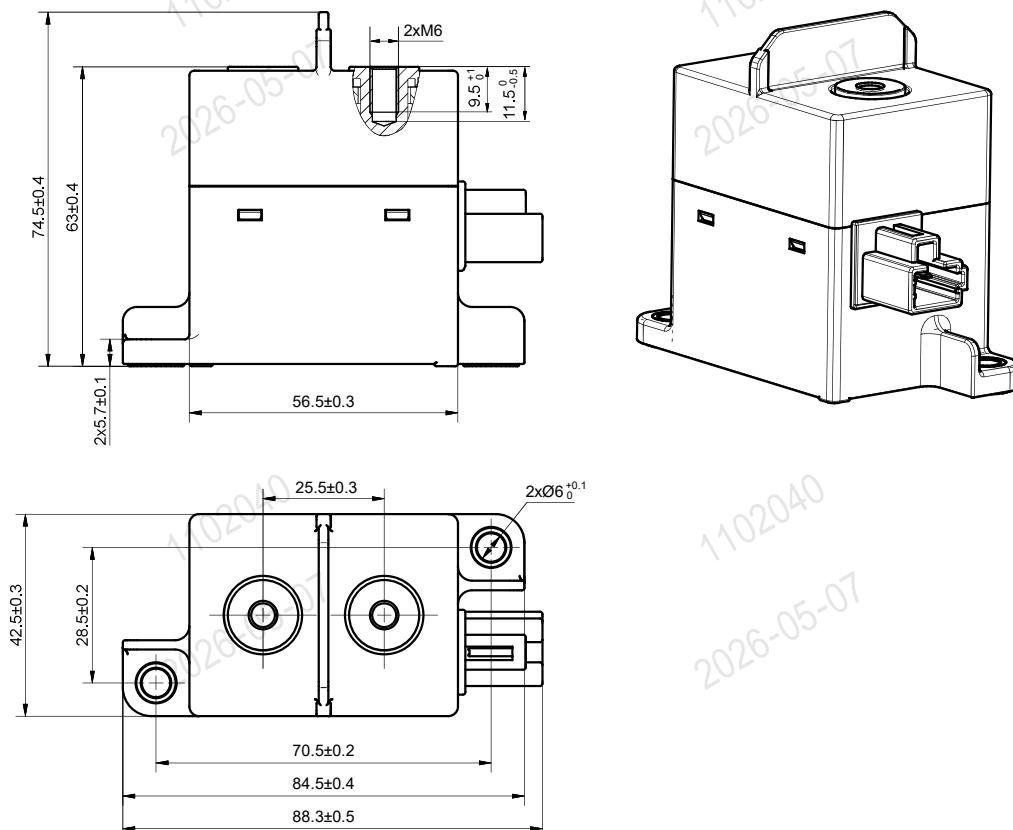

OUTLINE DIMENSIONS, MOUNTING HOLE, TERMINAL ARRANGEMENT

Unit: mm

Outline Dimensions

HFE82V-300C/XXX-XX-H-C5-1(917)

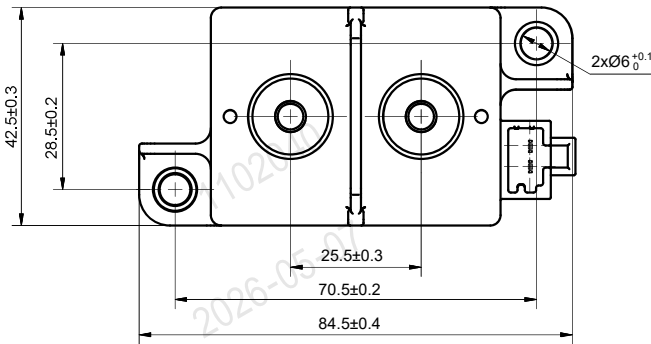
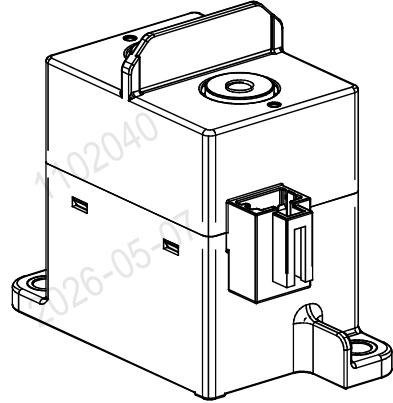
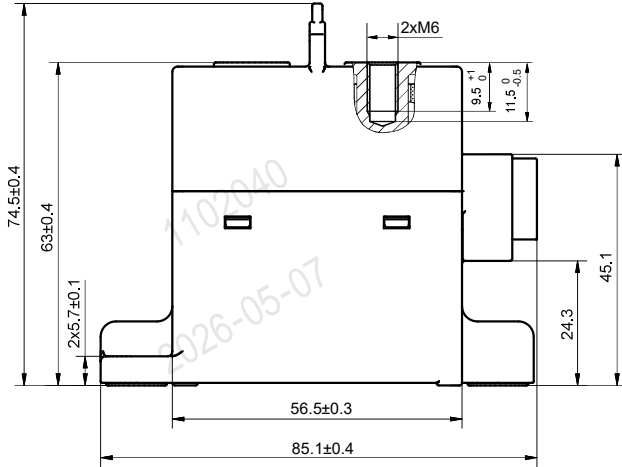

Mounting Hole

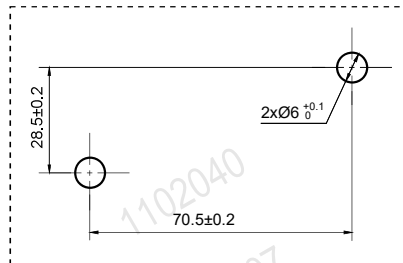

Terminal Arrangement

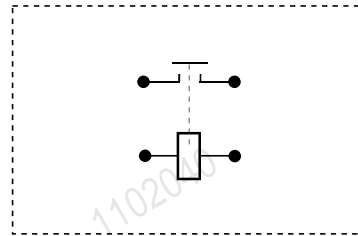

Notes: No polarity on the load and coil sides.

WIRING DIAGRAM

Unit: mm

C:Connector

(Configured by customers: THB 0435 series, Yazaki 7283-1020)

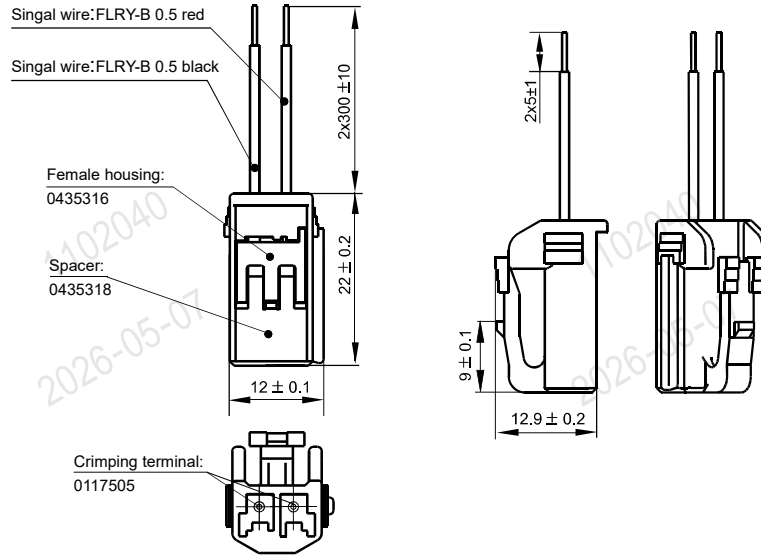

CHARACTERISTIC CURVES

Breaking Capability Curve (Resistive Load)

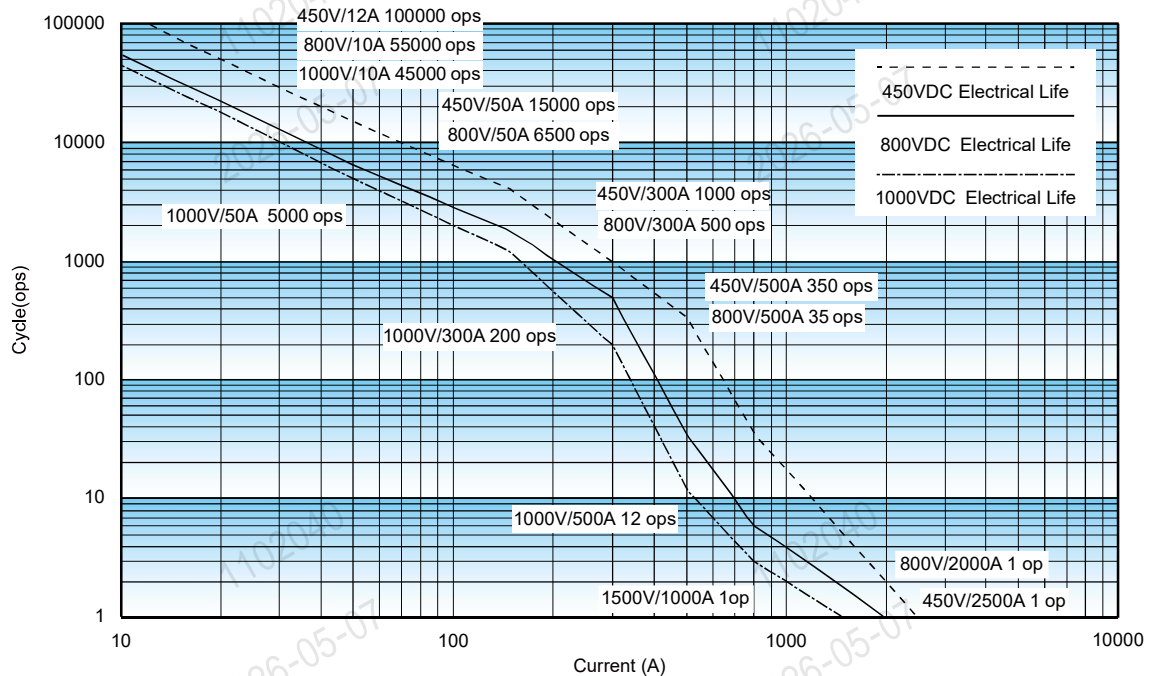

Notes:

- The data is for reference only.
- Cable cross section: $\geq 100 \text{mm}^2$.
- The data is measured under the resistive load ($L/R \leq 1 \text{ms}$), the duty cycle: 0.6s on: 5.4s off, ambient temperature: 23°C ;
The values may change according to the load type, duty cycle, and environmental conditions. therefore, it is recommended to confirm the values under actual load.

CHARACTERISTIC CURVES

Endurance Capacity Curve

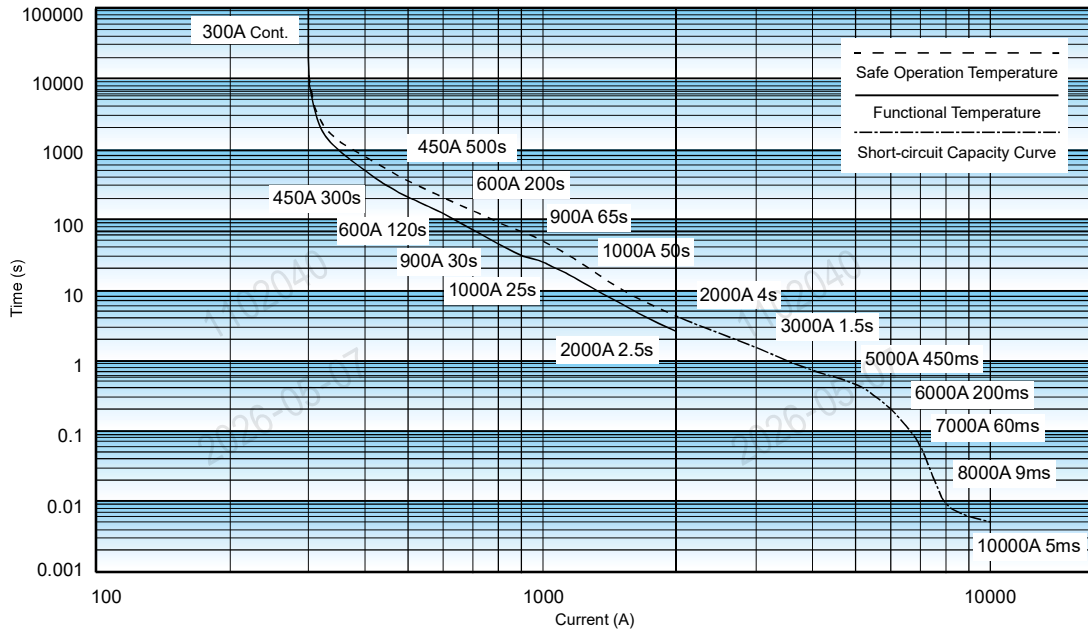

Notes:

1. The data is for design reference, it shall be verified as actual for model selection and fuse mating of short-circuit current test.
2. The upper temperature limit of safe operation and function are set for 180°C and 130°C respectively.
3. It is recommended that the upper temperature limit shall not exceed 130°C when long time operation. The relay may also fail, if the safe temperature limit of 180°C is exceeded.
4. Risks of fire and explosion may exist when the working condition beyond the safe circuit curve. In case of similar working condition, the relay shall be replaced in time.
5. The ambient temperature is 85°C for safe operation and function, and for current above 2000A, the temperature is room temperature with cross-sectional area $\geq 100\text{mm}^2$.
6. Even if it is below the safety curve when the current $\geq 2000\text{A}$, the relay is likely to be bonded during current carrying. If there is a break beyond the specification, fire and explosion may occur.
7. The contact is likely to bounce off when the current $\geq 8000\text{A}$. If the fuse cannot be fused in time, the relay may explode and may be ignited if the arc continues to burn after the explosion.
8. The contact will severely bounce off when the current $\geq 9000\text{A}$, which may cause the circuit current cannot continue to rise. If the fuse cannot be fused in time, the relay may explode and the arc may ignite the relay after the explosion.

Pick-up Voltage / Drop-out Voltage Curve

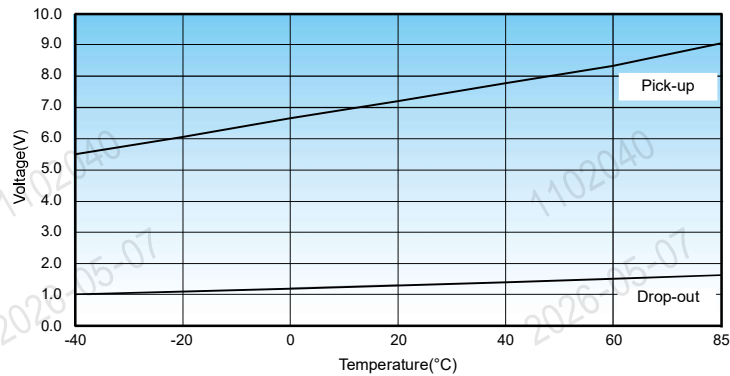

- Notes: 1) The above values are sampling values for reference only;
 2) The rated voltage of the sample coil is 12VDC;
 3) The sampling ambient temperature is -40°C~85°C.

CAUTIONS

1. In case of looseness, please use washer when install the relay with M5 screw, and the torque within 3N·m to 4N·m, The screw tightening torque at terminals shall be within 6N·m to 8N·m. The torque beyond the range may cause damage.

Mounting for load terminal				Mounting for relay body	
Mounting way	Torque requirement	Hole dia. of copper bus bar	Thickness of copper bus bar	Mounting way	Torque requirement
M6 Screw	6N·m ~ 8N·m	Ø6.0mm~Ø6.5mm	3mm	M5 Screw	3N·m ~ 4N·m

2. Please tighten the load terminal of relay vertically with preloading first when installing. Repeat locking is not recommended.
3. If any special screws and nuts, such as nylok, are used when installing, it is recommended to contact and confirm with Hongfa.
4. If any special installation requirements, such as downward direction, multi busbar connection, are involved, it is recommended to contact and confirm with Hongfa.
5. Please avoid adhering to foreign matter such as grease on the terminal lead end and please use the conductor with min. cross section area of 100mm², otherwise it may cause the abnormal heating of the terminal part.
6. The recommended thickness of copper bus-bar is 3mm, otherwise it may cause screw loose or can not guarantee a tight mounting.
7. Cautions of mounting for relay body:

Unrecommended method

Large opening of mounting plate at customer-side.

Enlarged Schematic Diagram:

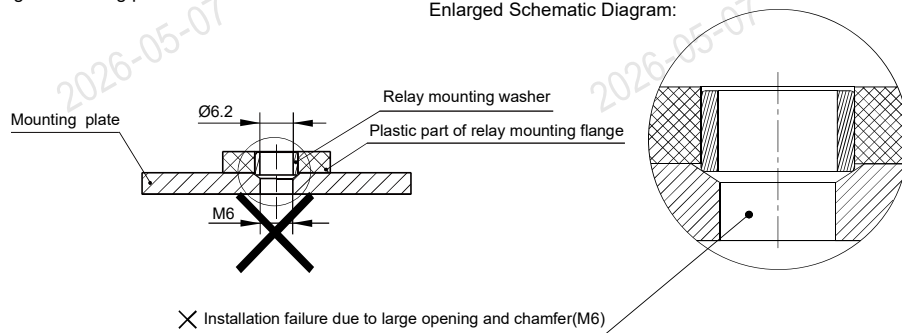

Recommended method

Appropriate opening (M5) of mounting plate at customer-side.

Enlarged Schematic Diagram:

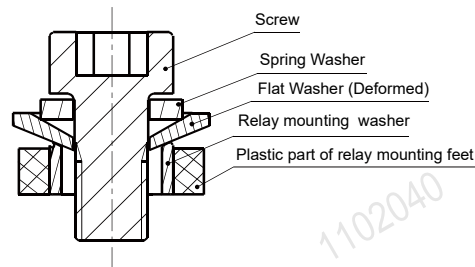
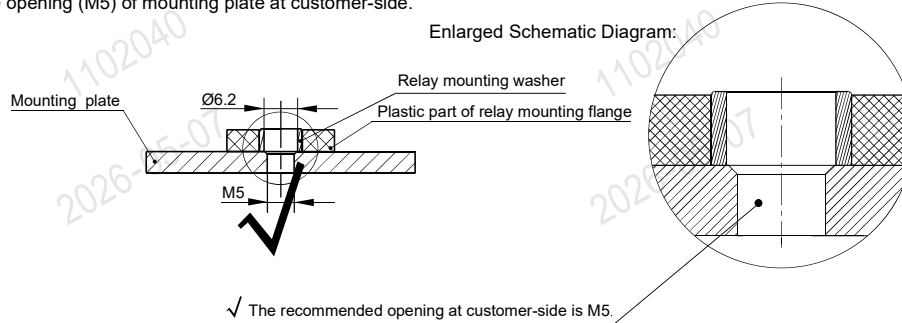

When use M5 screw, the thickness and strength of the washer needs to be guaranteed, or it may deform and burst the cover.

Disclaimer

The specification is for reference only. See to "Terminology and Guidelines" for more information. Specifications subject to change without notice. We could not evaluate all the performance and all the parameters for every possible application. Thus the user should be in a right position to choose the suitable product for their own application. If there is any query, please contact Hongfa for the technical service. However, it is the user's responsibility to determine which product should be used only.

© Xiamen Hongfa Electroacoustic Co.,Ltd. All rights of Hongfa are reserved.