

HR1-V

HIGH-VOLTAGE REED RELAY



File No.: R 50637175



File No.: E133481



Features

- High-voltage & High-insulation Reed Relay
- High insulation with 1500V reinforced insulation level
- Dielectric strength between open contacts $\geq 4000\text{VDC}$
- Dielectric strength between coil & contacts $\geq 7000\text{VDC}$
- High switching voltage at 1500VDC/1000VAC
- Combined injection molding structure for high vibration resistance
- SMT type available for convenient installation
- Meet the IEC 62477-1:2022 standard for energy storage systems

RoHS compliant

CONTACT DATA

Contact arrangement	1A
Contact resistance	100m Ω max.(10mA 30mVDC)
Contact material	Rhodium alloy
Contact rating(Res. load)	10mA 1500VDC 15mA 1000VDC 1mA 2000VDC 1A 30VDC
Max. switching voltage	2000VDC/1500VAC
Max. switching current	1.5A
Maximum making current	2.5A
Max. switching power	100W
Min. applicable load ³⁾	10mV 10 μ A
Mechanical endurance	1 $\times 10^8$ OPS
Electrical endurance	15mA 1000VDC (1 $\times 10^5$ OPS, 105 $^{\circ}$ C, 1s on/9s off) 10mA 1500VDC (1 $\times 10^5$ OPS, 105 $^{\circ}$ C, 1s on/9s off) 10mA 1000VAC (1 $\times 10^5$ OPS, 105 $^{\circ}$ C, 1s on/9s off) 1mA 2000VDC (1 $\times 10^5$ OPS, 85 $^{\circ}$ C, 1s on/9s off)

- Notes:** 1) The data shown above are initial values.
2) High voltage specification product characteristic number: AN3
3) Min. applicable load is reference value. Please perform the confirmation test with the actual load before production since reference value may change according to switching frequencies, environmental conditions and expected contact resistance and reliability.

COIL

Coil power	Approx. 300mW
Temperature rise	30K max.(1A Load, at 105 $^{\circ}$ C) 50K max.(2.5A Load, at 105 $^{\circ}$ C)

CHARACTERISTICS

Insulation resistance		10000M Ω (500VDC) 1T Ω max.(500VDC) (Typical values)
Dielectric strength	Between open contacts	Standard type: 3000VDC 1min High voltage ²⁾ : 4000VDC 1min
	Between coil & contacts	7000VDC 1min
Impulse voltage	Between open contacts	8000V(1.2/50 μ s)
	Between coil & contacts	8000V(1.2/50 μ s)
Operate time (Rated voltage, including bounce)		1.0ms max.
Release time (W/O freewheeling diode)		0.1ms max.
Vibration resistance		10Hz to 2000Hz, 20g
Shock resistance	Functional	490m/s ²
	Destructive	980m/s ²
Ambient temperature		-40 $^{\circ}$ C to 105 $^{\circ}$ C
Humidity		5% to 85%RH
Termination		THT, SMT
Moisture sensitivity levels (Only for SMT type, JEDEC-STD-020)		MSL-3
Unit weight		Approx. 5.0g
Construction		Plastic sealed

- Notes:** 1) The data shown above are initial values.
2) High voltage specification product characteristic number: AN3.

SAFETY APPROVAL RATINGS

UL/CUL	15mA 1000VDC(at 105 $^{\circ}$ C)
	10mA 1000VAC(at 105 $^{\circ}$ C)
	10mA 1500VDC(at 105 $^{\circ}$ C)
TÜV	15mA 1000VDC(at 105 $^{\circ}$ C)
	10mA 1500VDC(at 105 $^{\circ}$ C)

- Notes:** 1) Only typical loads are listed above. Other load specifications can be available upon request.



HONGFA RELAY

ISO9001, IATF16949, ISO14001, ISO45001, IECQ QC 080000, ISO/IEC 27001 CERTIFIED

2026 Rev. 1.00

COIL DATA

23°C

Coil Code	Nominal current VDC ¹⁾	Initial Pick-up Voltage VDC max.	Initial Drop-out Voltage VDC min.	Coil Resistance Ω	Nominal Power mW approx.	Max. Voltage VDC ³⁾
HR1-V/3	3	2.4	0.3	65 × (1±10%)	138	4.5
HR1-V/5	5	3.5	0.5	80 × (1±10%)	313	7.5
HR1-V/9	9	6.3	0.9	270 × (1±10%)	300	13.5
HR1-V/12	12	8.4	1.2	475 × (1±10%)	303	18.0
HR1-V/24	24	16.8	2.4	1800 × (1±10%)	320	36.0

Notes:1) The data shown above are initial values.

2) To supply rated step voltage to coil is the foundation of relay proper operation. Please make sure the applied voltage to the coil reach at rated values.

Please refer to the typical diagram below for single side stable relay. The "V_coil" is the rated voltage.:

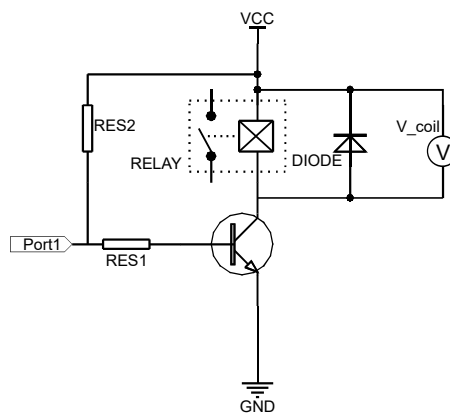

3) Maximum voltage refers to the maximum voltage which relay coil could endure in a short period of time.

4) When user's requirements can't be found in the above table, special order allowed.

5) During the relay pick-up or drop-out processes, there are stages of contact pressure change, contact vibration and unstable contact etc. When the voltage applied to coil is gradually changed, it will lengthen the unstable stage and affect relay endurance. To reduce this influence, please apply step voltage (switching circuit) to relay coil.

ORDERING INFORMATION

Type	HR1-V/	5	-H	S	R	(XXX)
Coil voltage	3, 5, 9, 12, 24					
Contact arrangement	H: 1 Form A					
Terminal type	S: SMT Nil: THT					
Packing style	R: Tape and reel packing (Only for SMT type) Nil: Tube packing (Only for DIP type)					
Special code	XXX: Customer special requirement Nil: Standard AN3: High voltage (Dielectric strength between open contacts ≥ 4000 VDC 1min) P01: Tape feeding direction reversed vs. standard. (Only for SMD types; see Tape Dimensions below.)					

Notes: 1) R type (tape and reel) packing is moisture-proof which meets requirement of MSL-3. Please choose R type packing for SMT products. For R type, the letter "R" will only be printed on packing tag but not on relay cover. Tube packing is normally not available for SMT products unless specially requested by customer. But please note that tube packing is not moisture-proof so please bake the products before use according to description of Notice 10 herewith. In addition, tube packaging will be adopted when the ordering quantity of R type is equal to or less than 100 pieces unless otherwise specified.

2) The customer special requirement express as special code after evaluating by Hongfa.

OUTLINE DIMENSIONS, WIRING DIAGRAM AND PC BOARD LAYOUT

Unit: mm

Outline Dimensions

PCB Layout(Top view)

DIP

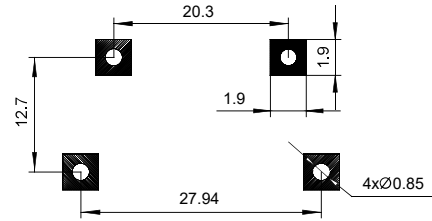
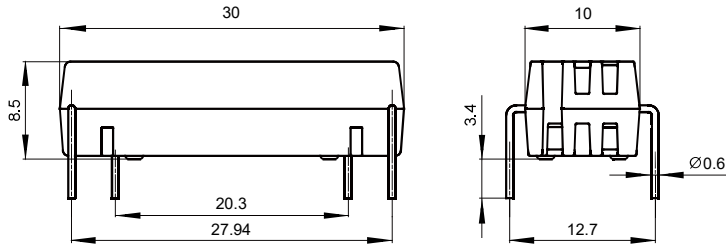

SMT

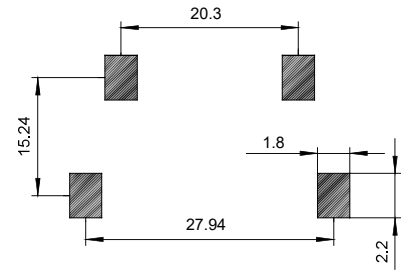
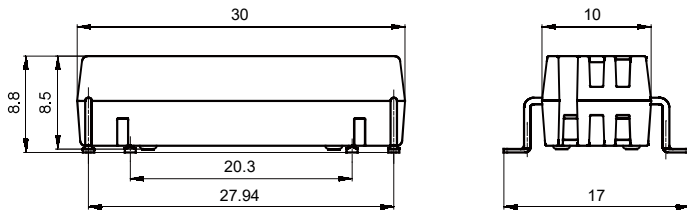

Wiring Diagram(Top view)

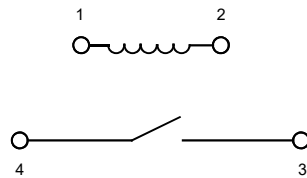

Remark: 1) In case of no tolerance shown in outline dimension: outline dimension ≤ 1 mm, tolerance should be ± 0.2 mm; outline dimension > 1 mm and ≤ 5 mm, tolerance should be ± 0.3 mm; outline dimension > 5 mm, tolerance should be ± 0.4 mm.
2) The tolerance without indicating for PCB layout is always ± 0.1 mm.

TAPE PACKING

Unit: mm

Direction of Relay Insertion

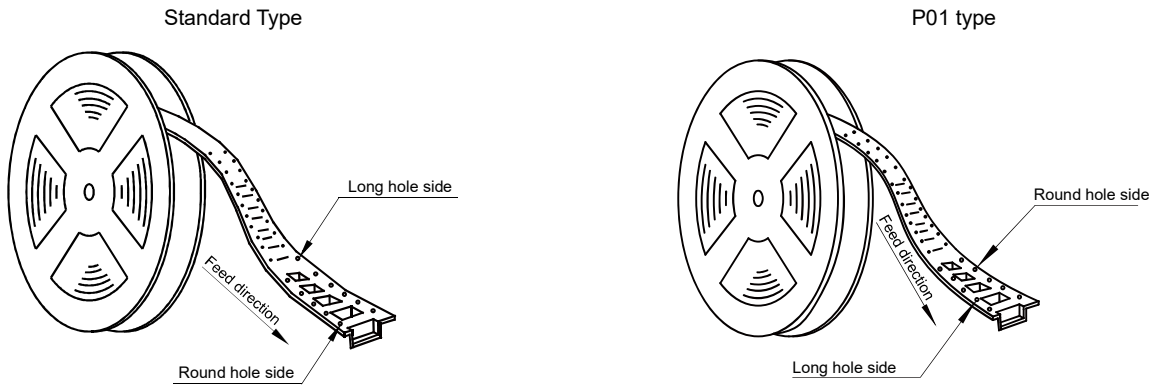

- Notes:** 1) Packing: 250pcs/reel, 3 reels/carton.
2) MOQ for reel packing is 250pcs.

Reel Dimensions

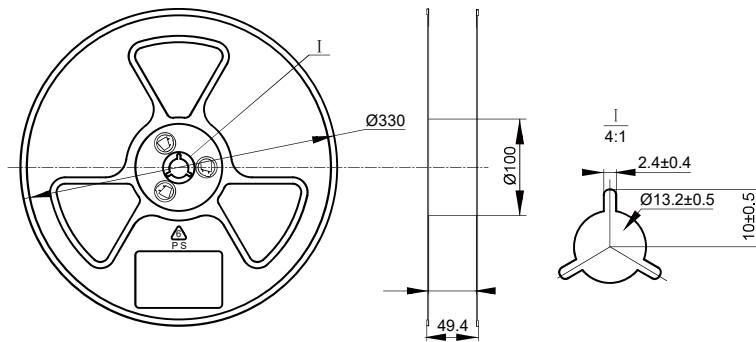

Tape Dimensions (Standard Type)

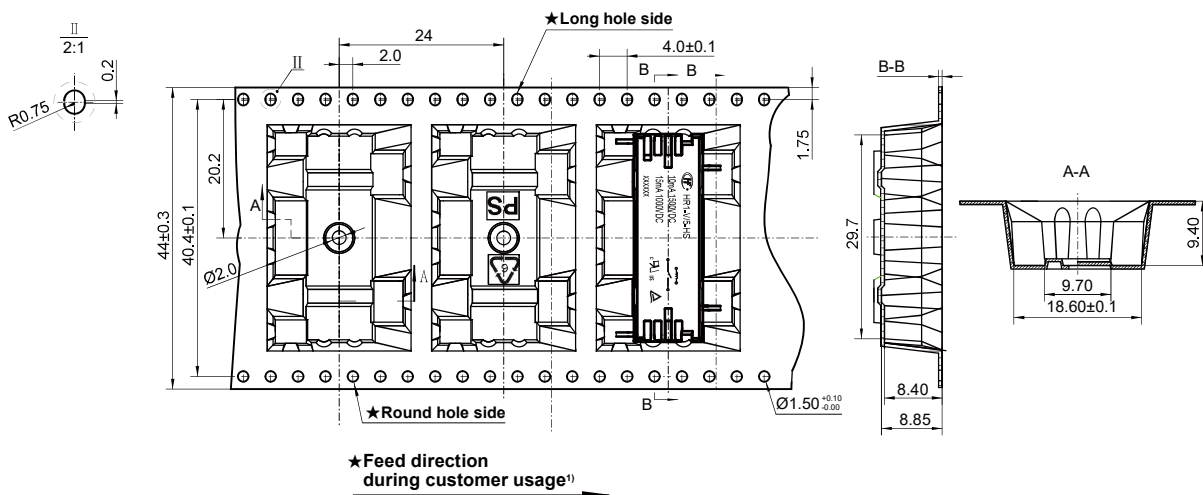

- Notes:** 1) Select the carrier tape feeding direction as indicated in the figure.

TAPE PACKING

Unit: mm

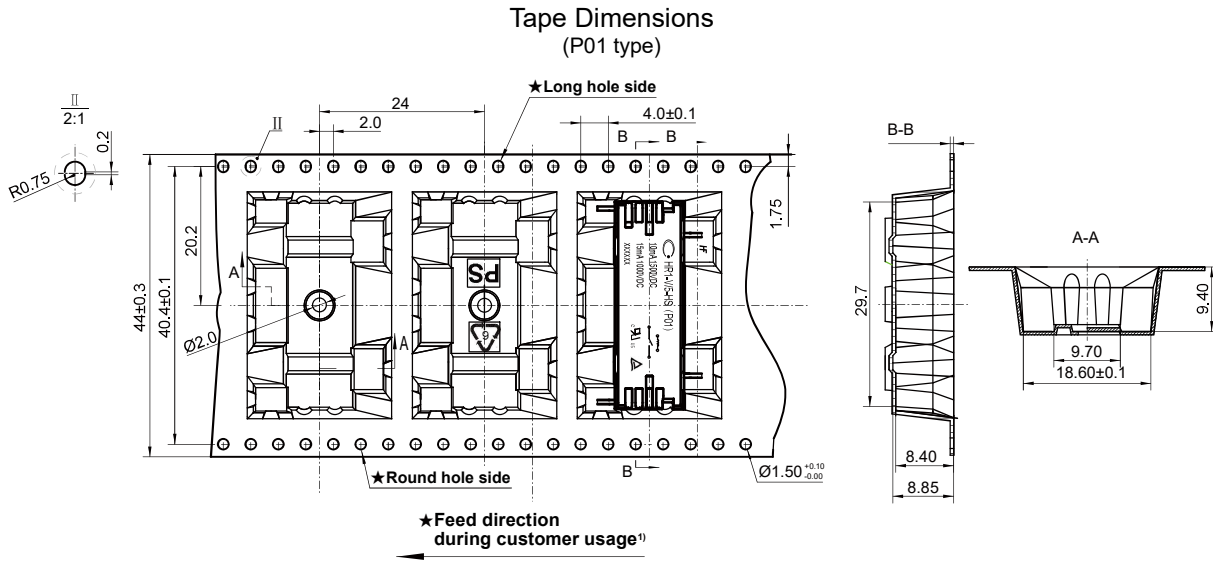

Notes: 1) Select the carrier tape feeding direction as indicated in the figure.

CHARACTERISTIC CURVES

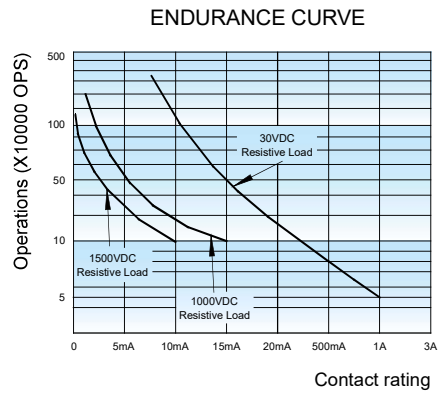
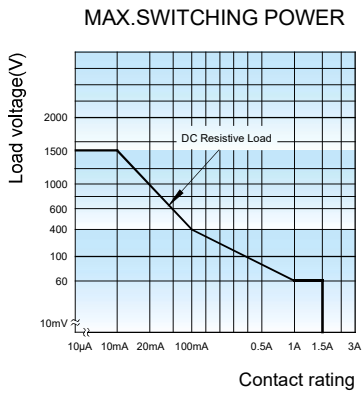

Test conditions: Resistive load, 1s on 9s off.

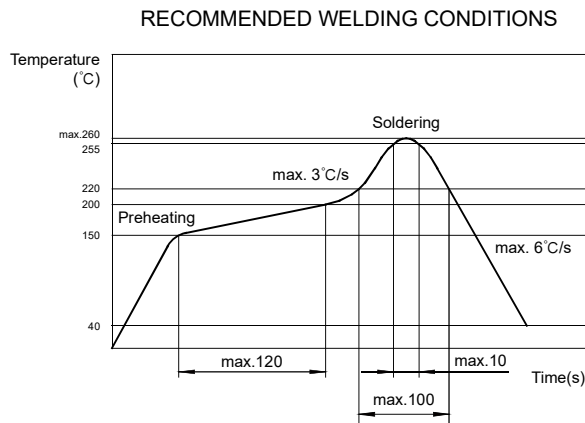

Notice

- 1) To avoid using relays under strong magnetic field which will change the parameters of relays such as pick-up voltage and drop-out voltage.
- 2) The relay action voltage and release/return voltage are the initial values tested under standard conditions (23°C). Applying rated voltage to both ends of the relay coil is the basis for normal operation of the relay. Considering the influence of environment temperature, coil temperature rise (such as hot start), voltage fluctuation, etc., in order to ensure the safety margin, make sure that the voltage applied to both ends of the relay coil reaches the rated voltage before use.
- 3) During the relay pick-up or drop-out processes, there are stages of contact pressure change, contact vibration and unstable contact etc. When the voltage applied to coil is gradually changed, it will lengthen the unstable stage and affect relay endurance. To reduce this influence, please apply step voltage (switching circuit) to relay coil.
- 4) For a monosteady state relay, after the relay is reliably operated, it is not recommended to use it for voltage reduction.
- 5) The relay may be damaged because of falling or when shocking conditions exceed the requirement.
- 6) For SMT products, validation with real application should be done before your series production, if the reflow-soldering temperature curve is out of our recommendation. Generally, two-time reflow-soldering is not recommended for the relay. However, if two-time reflow-soldering is required, a 60-min. interval should be guaranteed and a validation should be done before production.
- 7) Please use wave soldering or manual soldering for straight-in relay. If you need reflow welding, please confirm the feasibility with us.
- 8) Contact is recommended for suitable condition and specifications if water cleaning or surface process is involved in assembling relays on PCB.
- 9) Regarding the plastic sealed relay, we should leave it cooling naturally until below 40°C after welding, then clean it and deal with coating, remarkably the temperature of solvents should also be controlled below 40°C. Please avoid cleaning the relay by ultrasonic, avoid using the solvents like gasoline, Freon, and so on, which would affect the configuration of relay or influence the environment.
- 10) Relays packaged in moisture barrier bags meet MSL-3 requirements. The relays should be stored at ambient conditions of $\leq 30^{\circ}\text{C}$ and $\leq 60\%$ RH after they are removed from their packaging, and should be used within 168 hours. If the relays cannot be used within 168 hours, please repack them or store them in a drying oven at $25^{\circ}\text{C}\pm 5^{\circ}\text{C}$, $\leq 10\%$ RH. Otherwise, relays may be subjected to a soldering test to check their performance, or they may be used after keeping them in an oven for 72 hours at with $50^{\circ}\text{C}\pm 5^{\circ}\text{C}$, $\leq 30\%$ RH.
- 11) When applied with continuous current, the heat from relay coil will age its isolation. Thus, please do not ground connected the coil to reduce electrical erosion if possible. And please provide protection circuit to avoid broken wire and losses.
- 12) About preferable condition of operation, storage and transportation, please refer to "Explanation to terminology and guidelines of relay."

Disclaimer

The specification is for reference only. See to "Terminology and Guidelines" for more information. Specifications subject to change without notice. We could not evaluate all the performance and all the parameters for every possible application. Thus the user should be in a right position to choose the suitable product for their own application. If there is any query, please contact Hongfa for the technical service. However, it is the user's responsibility to determine which product should be used only.

© Xiamen Hongfa Electroacoustic Co., Ltd. All rights of Hongfa are reserved.