

HFD31

SUBMINIATURE SIGNAL RELAY

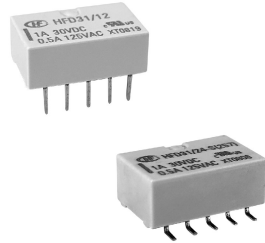

File No.:E133481



Features

- Offers excellent board space savings
- Surge withstand voltage up to 1500V, meets FCC Part 68
- High contact capacity 2A 30VDC
- Low power consumption
- Single side stable and latching type available
- Single or double coil winding type available

RoHS compliant

CONTACT DATA

Contact arrangement	2C
Contact resistance	100mΩ max. (at 10mA 30mVDC)
Contact material	AgNi + Au plated
Contact rating (Res. load)	1A 30VDC 2A 30VDC 0.5A 125VAC
Max. switching current	2A
Max. switching voltage	250VAC/220VDC
Max. switching power	62.5VA / 30W
Min. applicable load ¹⁾	10mV 10μA
Mechanical endurance	1 x 10 ⁸ OPS
Electrical endurance ²⁾	1 x 10 ⁵ OPS (0.5A 125VAC, Resistive load, AgNi + Au plated, at 70°C, 1s on 9s off)

- Notes:** 1) The data shown above are initial values.
 2) Min. applicable load is reference value. Please perform the confirmation test with the actual load before production since reference value may change according to switching frequencies, environmental conditions and expected contact resistance and reliability.
 3) Electrical endurance test is conducted with load being connected to NO or NC contacts.

COIL

Coil power	Single side stable	Approx. 140mW (24VDC: Approx. 200mW)
	1 coil latching	Approx. 100mW (24VDC: Approx. 150mW)
	2 coils latching	Approx. 200mW (24VDC: Approx. 300mW)

CHARACTERISTICS

Insulation resistance	1000MΩ (at 500VDC)	
Dielectric strength	Between coil & contacts	1500VAC 1min
	Between open contacts	750VAC 1min
	Between contact sets	1500VAC 1min
Surge withstand voltage Between open contacts (10/160μs)	1500VAC (FCC part 68)	
Operate time (Set time)	3ms max.	
Release time (Reset time)	3ms max.	
Ambient temperature	-40°C to 70°C	
Humidity	5% to 85% RH	
Vibration resistance	10Hz to 55Hz 3.0mm DA	
Shock resistance	Functional	735m/s ²
	Destructive	980m/s ²
Termination	THT, SMT	
Unit weight	Approx. 1.8g	
Moisture sensitivity levels (Only for SMT type, JEDEC-STD-020)	MSL-3	
Construction	Plastic sealed	

- Notes:** 1) The data shown above are initial values.
 2) UL insulation system: Class A.

SAFETY APPROVAL RATINGS

UL/CUL	AgNi + Au plated	1A 30VDC (70°C)
		2A 30VDC (40°C)
		0.5A 110VDC (70°C)
		0.5A 125VAC (70°C)

- Notes:** 1) All values unspecified are at room temperature.
 2) Only typical loads are listed above. Other load specifications can be available upon request.



HONGFA RELAY

ISO9001, IATF16949, ISO14001, OHSAS18001, IECQ QC 080000 CERTIFIED

2026 Rev. 1.00

COIL DATA

at 23°C

Single side stable

Coil Code	Nominal Voltage VDC ¹⁾	Initial Pick-up Voltage VDC ¹⁾ max.	Initial Drop-out Voltage VDC min.	Coil Resistance Ω	Nominal Power mW approx.	Max. Voltage VDC ⁴⁾
HFD31/1.5	1.5	1.13	0.15	16 x (1±10%)	140	3.0
HFD31/2.4	2.4	1.8	0.24	41.3 x (1±10%)	140	4.8
HFD31/3	3	2.25	0.3	64.3 x (1±10%)	140	6.0
HFD31/4.5	4.5	3.38	0.45	145 x (1±10%)	140	9.0
HFD31/5	5	3.75	0.5	178 x (1±10%)	140	10
HFD31/6	6	4.5	0.6	257 x (1±10%)	140	12
HFD31/9	9	6.75	0.9	579 x (1±10%)	140	18
HFD31/12	12	9	1.2	1028 x (1±10%)	140	24
HFD31/24	24	18	2.4	2880 x (1±10%)	200	48

1 coil latching

Coil Code	Nominal Voltage VDC ¹⁾	Initial Pick-up Voltage VDC ¹⁾ max.	Initial Drop-out Voltage VDC ¹⁾ min.	Coil Resistance Ω	Nominal Power mW approx.	Max. Voltage VDC ⁴⁾
HFD31/1.5-L1	1.5	1.13	1.13	22.5 x (1±10%)	100	3.0
HFD31/2.4-L1	2.4	1.8	1.8	58 x (1±10%)	100	4.8
HFD31/3-L1	3	2.25	2.25	90 x (1±10%)	100	6.0
HFD31/4.5-L1	4.5	3.38	3.38	203 x (1±10%)	100	9.0
HFD31/5-L1	5	3.75	3.75	250 x (1±10%)	100	10
HFD31/6-L1	6	4.5	4.5	360 x (1±10%)	100	12
HFD31/9-L1	9	6.75	6.75	810 x (1±10%)	100	18
HFD31/12-L1	12	9	9	1440 x (1±10%)	100	24
HFD31/24-L1	24	18	18	3840 x (1±10%)	150	48

2 coils latching

Coil Code	Nominal Voltage VDC ¹⁾	Initial Pick-up Voltage VDC ¹⁾ max.	Initial Drop-out Voltage VDC ¹⁾ min.	Coil Resistance Ω	Nominal Power mW approx.	Max. Voltage VDC ⁴⁾
HFD31/1.5-L2	1.5	1.13	1.13	11.3 x (1±10%)	200	3.0
HFD31/2.4-L2	2.4	1.8	1.8	29 x (1±10%)	200	4.8
HFD31/3-L2	3	2.25	2.25	45 x (1±10%)	200	6.0
HFD31/4.5-L2	4.5	3.38	3.38	101 x (1±10%)	200	9.0
HFD31/5-L2	5	3.75	3.75	125 x (1±10%)	200	10
HFD31/6-L2	6	4.5	4.5	180 x (1±10%)	200	12
HFD31/9-L2	9	6.75	6.75	405 x (1±10%)	200	18
HFD31/12-L2	12	9	9	720 x (1±10%)	200	24
HFD31/24-L2	24	18	18	1920 x (1±10%)	300	48

COIL DATA

at 23°C

Notes:1) The data shown above are initial values.

2) To supply rated step voltage to coil is the foundation of relay proper operation. Please make sure the applied voltage to the coil reach at rated values.

Please refer to the typical diagram below for single side stable relay. The "V_coil" is the rated voltage:

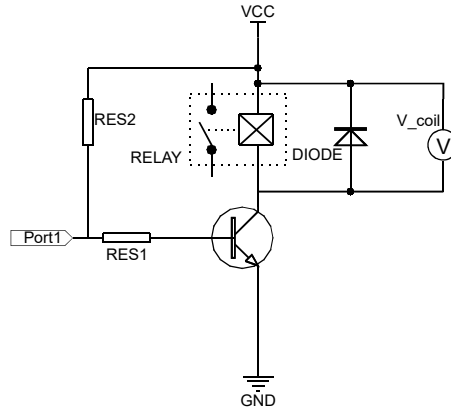

3) In case 5V of transistor drive circuit, it is recommended to use 4.5V type relay, and 3V to use 2.4V type relay.

4) For monostable relays, if you need to drop down voltage and hold mode after reliably operating, make sure that the effective value of holding voltage is not less than 60% of the rated voltage.

5) Maximum voltage refers to the maximum voltage which relay coil could endure in a short period of time.

6) When user's requirements can't be found in the above table, special order allowed.

7) During the relay pick-up or drop-out processes, there are stages of contact pressure change, contact vibration and unstable contact etc. When the voltage applied to coil is gradually changed, it will lengthen the unstable stage and affect relay endurance. To reduce this influence, please apply step voltage (switching circuit) to relay coil.

ORDERING INFORMATION

Type	HFD31 /	24	-L1	S	R	(XXX)
Coil voltage	1.5, 2.4, 3, 4.5, 5, 6, 9, 12, 24VDC					
Sort	L1: 1 coil latching		L2: 2 coils latching			
	Nil: Single side stable					
Terminal type	S: Standard SMT		S1: Short terminal SMT		Nil: THT ¹⁾	
Packing style	R: Tape and reel packing (Only for SMT type) ²⁾					
	Nil: Tube packing (Only for THT type)					
Special code ³⁾	XXX: Customer special requirement			Nil: Standard		

Notes: 1) THT relays: Use wave or manual soldering. Confirm reflow soldering feasibility with us first.

2) R type (tape and reel) packing is moisture-proof which meets requirement of MSL-3. Please choose R type packing for SMT products. For R type, the letter "R" will only be printed on packing tag but not on relay cover. Tube packing is normally not available for SMT products unless specially requested by customer. But please note that tube packing is not moisture-proof so please bake the products before use according to description of Notice 11 herewith. In addition, tube packaging will be adopted when the ordering quantity of R type is equal to or less than 100 pieces unless otherwise specified.

3) The customer special requirement express as special code after evaluating by Hongfa.

4) Standard tube packing length is 580mm. Any special requirement needed, please contact us for more details.

5) For products that should meet the explosion-proof requirements of "IEC 60079 series", please note [Ex] after the specification while placing orders. Not all products have explosion-proof certification, so please contact us if necessary, in order to select the suitable products.

OUTLINE DIMENSIONS, WIRING DIAGRAM AND PC BOARD LAYOUT

Unit: mm

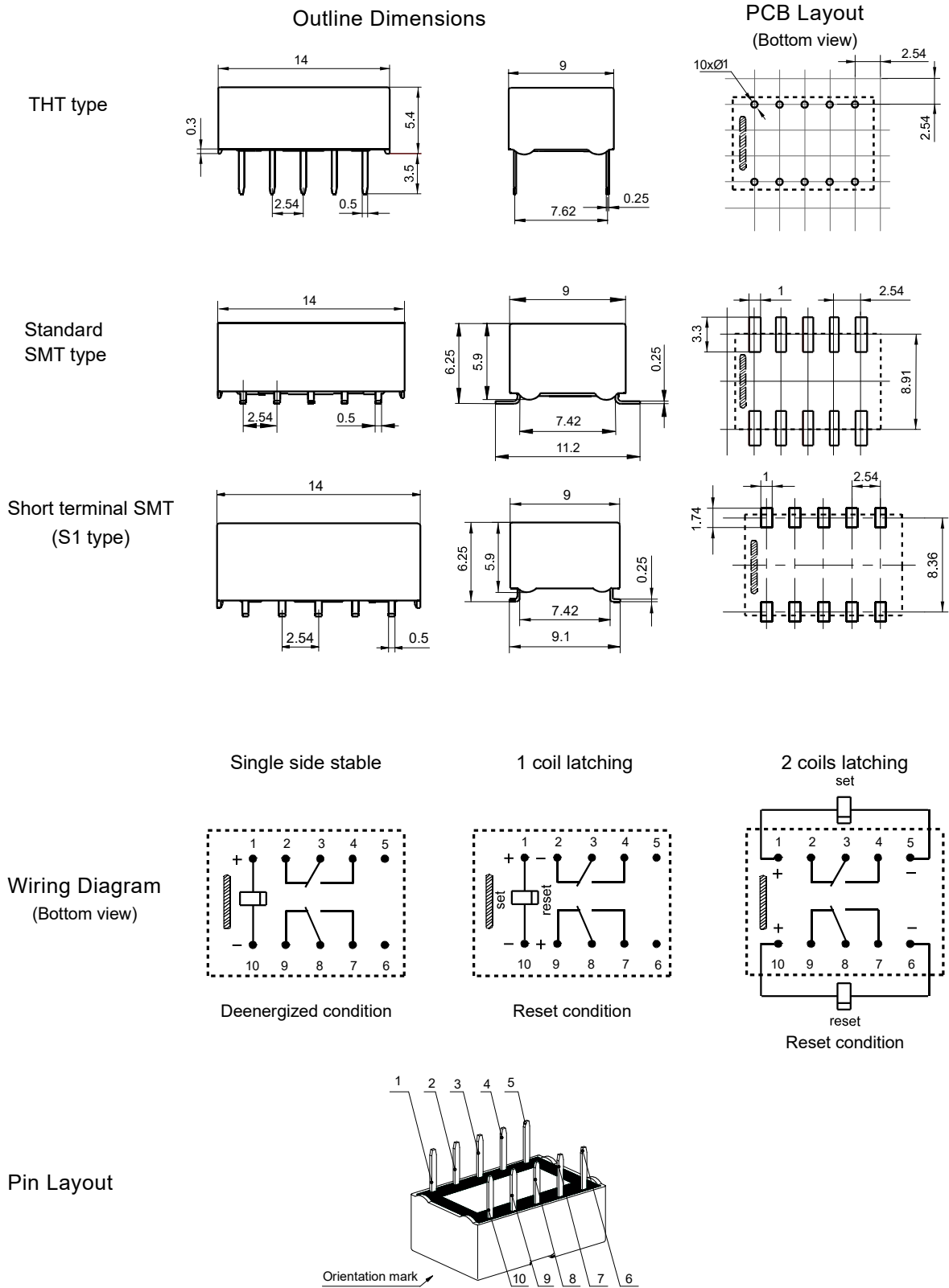

Remark: 1) The pin dimension of the product outline drawing is the size before tinning (it will become larger after tinning), and the mounting hole size is the recommended design size of the PCB board hole. The specific PCB board hole design size can be mapped and adjusted according to the actual product.
 2) In case of no tolerance shown in outline dimension: outline dimension ≤ 1 mm, tolerance should be ± 0.2 mm; outline dimension > 1 mm and ≤ 5 mm, tolerance should be ± 0.3 mm; outline dimension > 5 mm, tolerance should be ± 0.4 mm.
 3) The tolerance without indicating for PCB layout is always ± 0.1 mm.

TAPE & REEL PACKING CONSTRUCTION AND DIMENSION

Unit: mm

Reel Dimensions

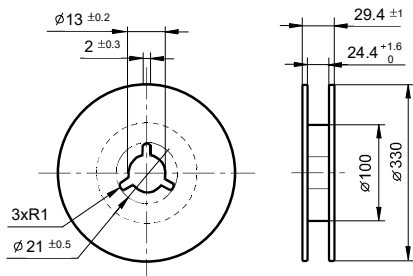

Direction of Relay Insertion

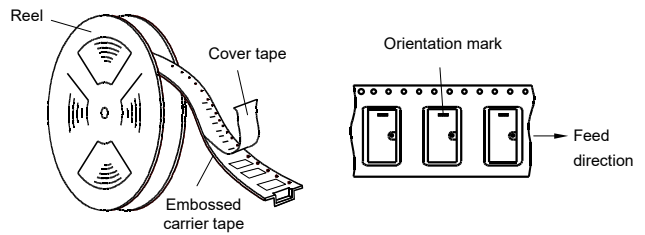

- Notes:** 1) Packing: 550pcs/reel, 4 reels/carton.
2) MOQ for reel packing is 550pcs.

Tape Dimensions (S type:Standard SMT type)

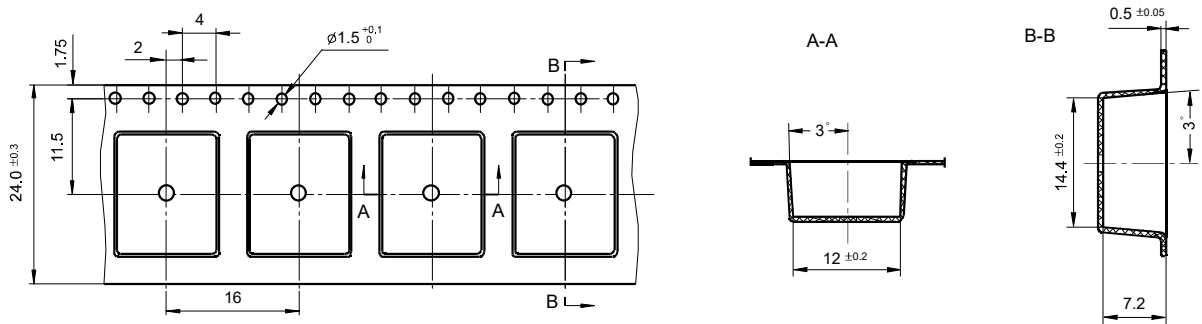

Tape Dimensions (Short terminal SMT)

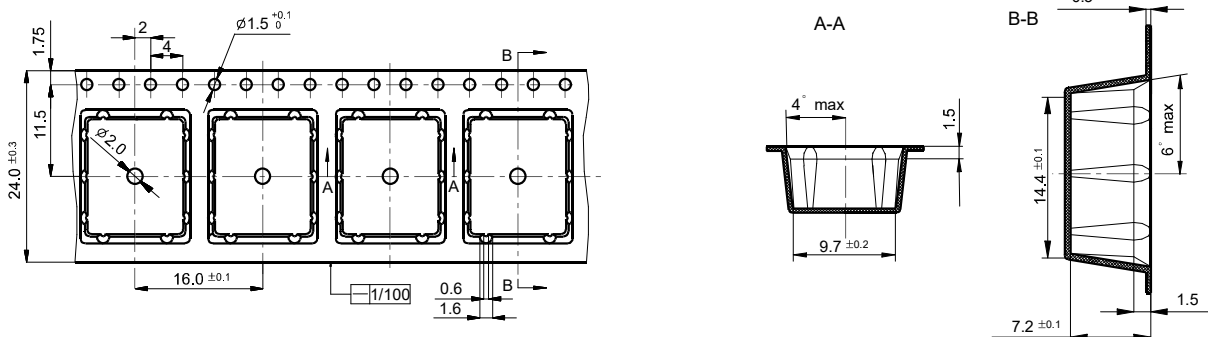

RECOMMENDED SOLDERING CONDITIONS

REFLOW WELDING, TEMPERATURE ON PCB BOARD

RECOMMENDED WELDING TEMPERATURE

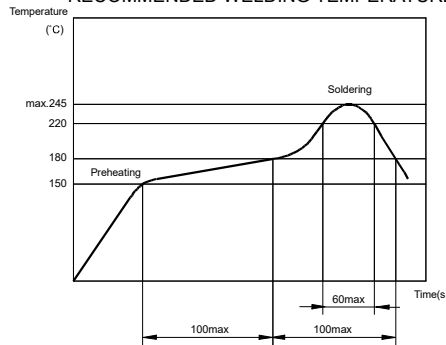

(Only for SMT type)

- Notes:** 1) Temperature profile shows Printed Circuit Board surface temperature on the relay terminal portion.
2) Please check the actual soldering condition to use other method except above mentioned temperature profiles.

CHARACTERISTIC CURVES

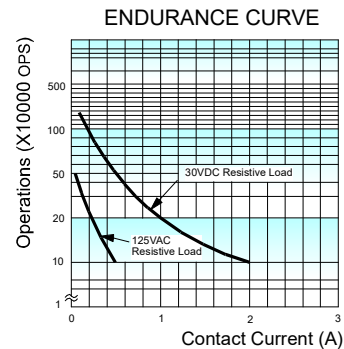
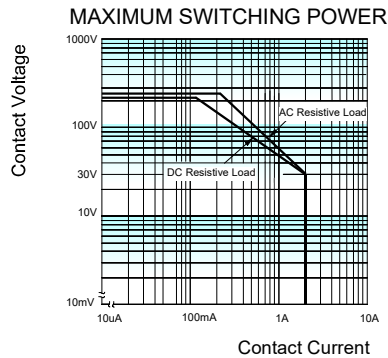

Test conditions:
Resistive load, at 40°C, 1s on 9s off.

Notice

- 1) This relay is highly sensitive polarized relay, if correct polarity is not applied to the coil terminals, the relay does not operate properly.
- 2) To avoid using relays under strong magnetic field which will change the parameters of relays such as pick-up voltage and drop-out voltage.
- 3) Relay is on the "reset" status when being released from stock, with the consideration of shock risen from transit and relay mounting, it should be changed to the "set" status when application(connecting to the power supply). Please reset the relay to "set" or "reset" status on request.
- 4) Energizing coil with rated voltage is basic for normal operation of a relay, please make sure the energized voltage to relay coil have reached the rated voltage. Regarding latching relay, in order to maintain the "set" or "reset" status, impulse width of the rated voltage applied to coil should be more than 5 times of "set" or "reset" time.
- 5) For a monosteady state relay, after the relay is reliably operated, if it needs to be kept under pressure, make sure that the effective value of the voltage is not less than 60 % of the rated voltage;
- 6) For 2 coil latching relay, do not energize voltage to "set" coil and "reset" coil simultaneously.
- 7) The relay may be damaged because of falling or when shocking conditions exceed the requirement.
- 8) For SMT products, validation with real application should be done before your series production, if the reflow-soldering temperature curve is out of our recommendation. Generally, two-time reflow-soldering is not recommended for the relay. However, if two-time reflow-soldering is required, a 60-min. interval should be guaranteed and a validation should be done before production.
- 9) Please use wave soldering or manual soldering for straight-in relay. If you need reflow welding, please confirm the feasibility with us.
- 10) Contact is recommended for suitable condition and specifications if water cleaning or surface process is involved in assembling relays on PCB.
- 11) Regarding the plastic sealed relay, we should leave it cooling naturally until below 40°C after welding, then clean it and deal with coating, remarkably the temperature of solvents should also be controlled below 40°C. Please avoid cleaning the relay by ultrasonic, avoid using the solvents like gasoline, Freon, and so on, which would affect the configuration of relay or influence the environment.
- 12) Relays packaged in moisture barrier bags meet MSL-3 requirements. The relays should be stored at ambient conditions of $\leq 30^{\circ}\text{C}$ and $\leq 60\%$ RH after they are removed from their packaging, and should be used within 168 hours. If the relays cannot be used within 168 hours, please repack them or store them in a drying oven at $25^{\circ}\text{C} \pm 5^{\circ}\text{C}$, $\leq 10\%$ RH. Otherwise, relays may be subjected to a soldering test to check their performance, or they may be used after keeping them in an oven for 72 hours at with $50^{\circ}\text{C} \pm 5^{\circ}\text{C}$, $\leq 30\%$ RH.
- 13) When applied with continuous current, the heat from relay coil will age its isolation. Thus, please do not ground connected the coil to reduce electrical erosion if possible. And please provide protection circuit to avoid broken wire and losses.
- 14) Please make sure that there are no silicon-based substances (such as silicon rubber, silicone oil, silicon-based coating agents, silicon fillers, etc.) around the relay, because it will generate silicon-containing volatile gas, which may cause poor contact in case of silicon-containing volatile gas sticking on contact
- 15) About preferable condition of operation, storage and transportation, please refer to "Explanation to terminology and guidelines of relay"
- 16) During the relay pick-up or drop-out processes, there are stages of contact pressure change, contact vibration and unstable contact etc. When the voltage applied to coil is gradually changed, it will lengthen the unstable stage and affect relay endurance. To reduce this influence, please apply step voltage (switching circuit) to relay coil.

Disclaimer

The specification is for reference only. See to "Terminology and Guidelines" for more information. Specifications subject to change without notice. We could not evaluate all the performance and all the parameters for every possible application. Thus the user should be in a right position to choose the suitable product for their own application. If there is any query, please contact Hongfa for the technical service. However, it is the user's responsibility to determine which product should be used only.

© Xiamen Hongfa Electroacoustic Co., Ltd. All rights of Hongfa are reserved.