

HFV9

AUTOMOTIVE RELAY



Typical Applications

Headlight control, Fuel pump control, Horn control, A/C compressor clutch

Features

- Extended temp. range up to 125°C
- 1 Form A & 1 Form C contact arrangement
- 2.8mm QC terminals
- RoHS & ELV compliant

CHARACTERISTICS

Contact arrangement	1A, 1C
Voltage drop (initial)	NO:Typ.20mV,250mV max.(at 10A) NC:Typ.25mV,250mV max.(at 10A)
Max.continuous current ^{1) 8)}	NO:30A(at 23°C), 25A(at 85°C),13A(at 125°C) NC:20A(at 23°C), 15A(at 85°C),10A(at 125°C)
Max.switching current ⁸⁾	Make(NO): 100A ²⁾ Break(NO): 30A (Resistive, 13.5VDC)
Min. contact load	1A 12VDC
Electrical endurance	See "CONTACT DATA"
Mechanical endurance	1x10 ⁷ OPS 300OPS/min
Initial insulation resistance	100MΩ (at 500VDC)
Withstand voltage ³⁾	between contacts: 500VAC between coil & contacts: 500VAC
Operate time ⁸⁾	Typ.: 5ms (at nomi. vol.) Max.: 10ms (at nomi. vol.)
Release time ^{4) 8)}	Typ.: 3ms Max.: 10ms
Ambient temperature	-40°C to 125°C
Vibration resistance ^{5) 8)}	10Hz to 2000Hz 31.5m/s ²

Shock resistance ^{5) 8)}	196m/s ²
Flammability ⁶⁾	UL94-HB or better (meets FMVSS 302)
Termination	2.8mm QC ⁹⁾
Construction	Plastic sealed, Dust protected
Unit weight	Approx. 20g
Mechanical data	cover retention (pull & push): 200N min. terminal retention (pull & push): 100N min. terminal resistance to bending (front & side): 10N min. ⁷⁾

- 1) For NO contacts, measured when applying 100% rated voltage on coil.
- 2) Inrush peak current under lamp load, at 13.5VDC.
- 3) 1min, leakage current less than 1mA.
- 4) The value is measured when voltage drops suddenly from nominal voltage to 0 VDC and coil is not paralleled with suppression circuit.
- 5) When energized, opening time of NO contacts shall not exceed 1ms, when non-energized, opening time of NC contacts shall not exceed 1ms, meantime, NO contacts shall not be closed.
- 6) FMVSS: Federal Motor Vehicle Safety Standard.
- 7) Test point is at 2mm away from terminal end, and after removing testing force, the terminal transfiguration shall not exceed 0.5mm.
- 8) Only for the 12VDC coil voltage type.
- 9) Do NOT knock on relays with hard objects such as rubber rod and rubber hammer during mounting, which might lead to relay damage.

CONTACT DATA ²⁾³⁾

Load voltage	Load type		Load current A			On/Off ratio		Electrical endurance OPS	Contact material	Load wiring diagram ¹⁾	Ambient temp.
			1C		1A	On s	Off s				
			NO	NC							
13.5VDC	Resistive	Make	20	10	30	2	2	1×10 ⁵	AgSnO ₂	See diagram 1	See Ambient Temp. Curve
		Break	20	10	30						
	Lamp	Make	100	—	100	2	2	1×10 ⁵	AgSnO ₂	See diagram 2	
		Break	20	—	20						
	Inductive	Make	40	20	40	2	4	1×10 ⁵	AgSnO ₂	See diagram 3	
		Break	20	10	20						
27VDC	Resistive	Make	20	10	20	2	2	1×10 ⁵	AgSnO ₂	See diagram 1	
		Break	20	10	20						



HONGFA RELAY

ISO9001, IATF16949, ISO14001, ISO45001, IECQ QC 080000, ISO/IEC 27001 CERTIFIED

2026 Rev. 1.00

1) The load wiring diagrams are listed below (Ratings of NO, NC are tested based on different samples separately) :

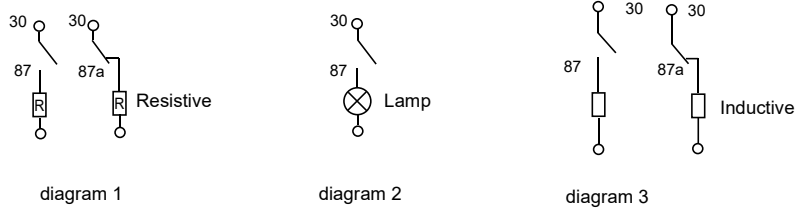

- 2) Loads mentioned in this chart is for relays with no parallel diode or Zener Diode. For those with parallel diode, Zener Diode or other components, please contact Hongfa for more technical supports.
Please also contact Hongfa if the actual application load is different from what mentioned above.
- 3) The 24V motor control for wipers, windows and door locks is a special application with highly dynamic inductive loads. To ensure reliability, please confirm key details with our technical support before product selection.

COIL DATA

at 23°C

Nominal voltage VDC	Pick-up voltage VDC max.	Drop-out voltage VDC min.	Coil resistance $\times(1\pm 10\%)\Omega$	Parallel resistance $\times(1\pm 5\%)\Omega$	Equivalent resistance Ω	Power consumption W	Max. allowable overdrive voltage ¹⁾ VDC	
							at 23°C	at 85°C
12	8	1	109	—	—	1.3	20.4	14.9
12	8	1	109	680	93.9	1.5	20.4	14.9
24	16	2	360	—	—	1.6	36	28
24	16	2	360	2700	317.6	1.8	36	28

1) Max. allowable overdrive voltage is stated with no load applied.

ORDERING INFORMATION

	HFV9 / 012 -1H S R (XXX)
Type	
Coil voltage	012: 12VDC 024: 24VDC
Contact arrangement	1H: 1 Form A 1Z: 1 Form C
Construction	S: Plastic sealed ¹⁾ Nil: Dust protected
Parallel coil components²⁾	R: Parallel transient suppression resistors D: Parallel transient suppression diode, with anode connected to terminal#85 D1: Parallel transient suppression diode, with anode connected to terminal#86 Nil: Without parallel components
Special code³⁾	XXX: Customer special requirement Nil: Standard

- Notes:** 1) In environments with high humidity, moisture, or even condensation, and dust, such as relays used in engineering, mining, agriculture and other fields, or relays with mounting brackets installed outside of electrical boxes, it is recommended to use plastic-encapsulated products; in environments containing phosphorus, H₂S, SO₂, NO₂ and other harmful gases, plastic-encapsulated types must be used and tested and confirmed in actual use; in environments containing organic silicon, please avoid using dust-proof covers ;
- 2) If parallel diode, Zener Diode or other components are required, please contact Hongfa for more technical supports.
- 3) The customer special requirement express as special code after evaluating by Hongfa. e.g. (170) stands for flasher load. The performance parameters of products with characteristic numbers shall be subject to the specific specifications provided by Hongfa.

OUTLINE DIMENSIONS, WIRING DIAGRAM AND PC BOARD LAYOUT

Unit: mm

Outline Dimensions

HFV9/□□□-1H□□(XXX)

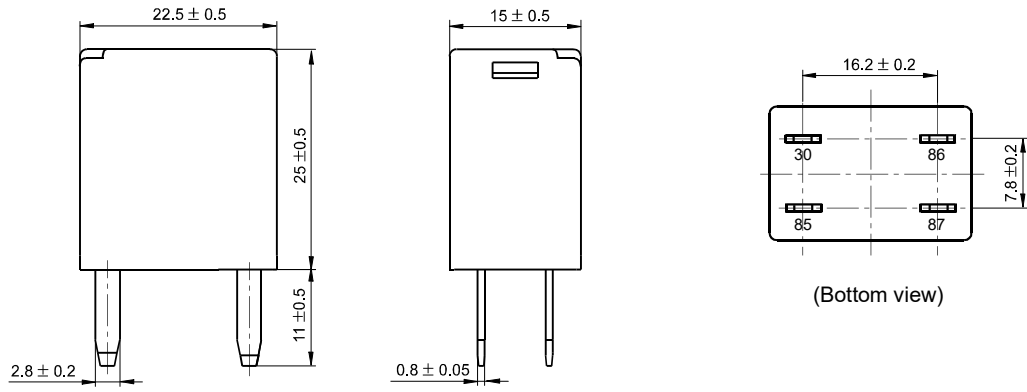

HFV9/□□□-1Z□□(XXX)

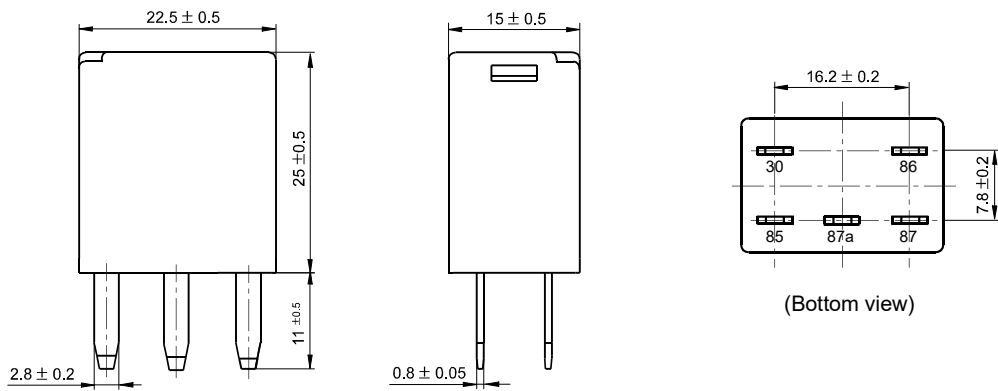

Remark: Terminal vertical deviation tolerance is 0.3mm.

Wiring Diagram

HFV9/□□□-1H□□(XXX)

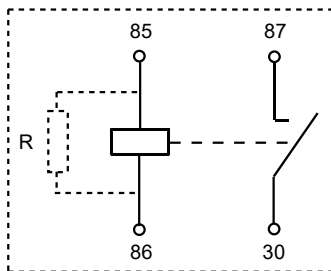

HFV9/□□□-1Z□□(XXX)

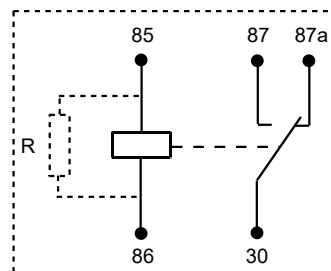

CHARACTERISTIC CURVES

1. Coil operating voltage range

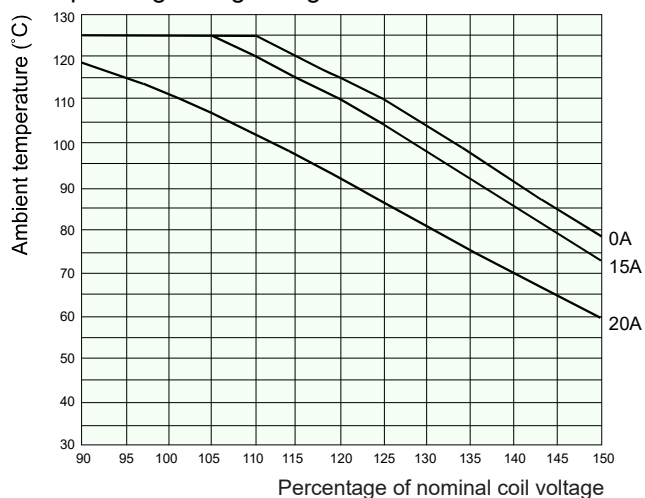

- 1) There should be no contact load applied when maximum continuous operation voltage is applied on coil.
- 2) This chart takes 12VDC coil voltage version as example.
- 3) The maximum allowable coil temperature is 180°C. For the coil temperature rise which is measured by resistance is average value, we recommend the coil temperature should be below 170°C under the different application ambient, different coil voltage and different load etc.
- 4) If the actual operating coil voltage is out of the specified range, please contact Hongfa for further details.

2. Ambient temperature curve of the electrical endurance test

Ambient temp. curve (one cycle)

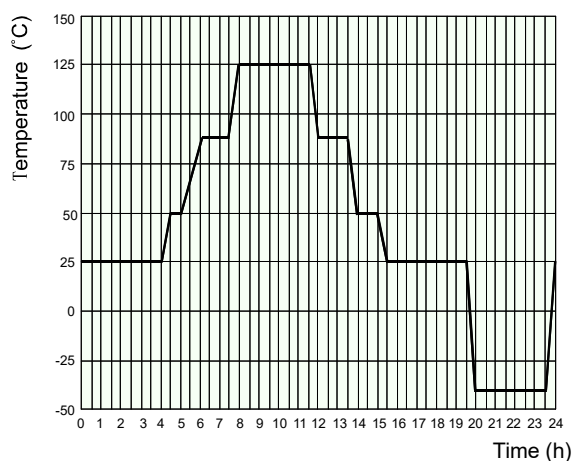

- 1) The minimum temperature is -40°C.
- 2) The maximum temperature is 125°C.

Disclaimer

The specification is for reference only. See to "Terminology and Guidelines" for more information. Specifications subject to change without notice. In case there is specific criterion (such as mission profile, technical specification, PPAP etc.) checked and agreed by and between customer and Hongfa, this specific criterion should be taken as standard regarding any requirement on Hongfa product. We could not evaluate all the performance and all the parameters for every possible application. Thus the user should be in a right position to choose the suitable product for their own application. If there is any query, please contact Hongfa for the technical service. However, it is the user's responsibility to determine which product should be used only.

© Xiamen Hongfa Electroacoustic Co., Ltd. All rights of Hongfa are reserved.