

# HF165F-50

# MINIATURE HIGH POWER RELAY



File No:E134517



File No:R 50463438



File No:CQC18002189685



## Features

- 50A switching capability
- 4kV dielectric strength(between coil and contacts)
- Contact category :CC2
- UL insulation system: class F available
- Products compliant with IEC 60079 available
- Products compliant with IEC 60335 available

**RoHS compliant**

## CONTACT DATA

Contact arrangement	1A
Voltage drop <sup>1)</sup>	100mV max.(at 10A 13.5VDC)
Contact material	AgSnO <sub>2</sub> /AgNi
Contact rating (Res. load)	50A 250VAC
Max. switching voltage	250VAC
Max. switching current <sup>2)</sup>	50A
Max. switching power	12500VA
Mechanical endurance	1 x 10 <sup>6</sup> OPS
Electrical endurance	1x10 <sup>4</sup> OPS(50A 250VAC, Resistive load, at 65°C, 1s on 9s off,AgNi/AgSnO <sub>2</sub> ) 3x10 <sup>4</sup> OPS(40A 250VAC, Resistive load, at 85°C, 1s on 9s off,AgSnO <sub>2</sub> )

**Notes:** 1)The data shown above are initial values.  
2)The relay connections and wiring have to be designed with an adequate cross sections to ensure the current flow and heat dissipation.

## CHARACTERISTICS

Insulation resistance	1000MΩ (at 500VDC)
Dielectric strength	Between coil & contacts 4000VAC 1min
	Between open contacts 1500VAC 1min
Surge voltage (between coil & contacts)	6kV (1.2/50μs)
Operate time (at rated. volt.)	15ms max.
Release time (at rated. volt.)	10ms max.
Temperature rise	90K max.(Contact load current 50A, rated voltage excitation, at 65°C)
Shock resistance	Functional 98m/s <sup>2</sup>
	Destructive 980m/s <sup>2</sup>
Vibration resistance	10Hz to 55Hz 1.5mm DA
Ambient temperature	-40°C to 105°C
Humidity	5% to 85% RH
Termination	PCB
Unit weight	Approx.36g
Construction	Flux proofed

**Notes:** The data shown above are initial values.

## COIL

Coil power	Standard type: Approx.1.2W Sensitive type: Approx.0.9W
------------	---

## COIL DATA

at 23°C

### Standard type

Nominal Voltage VDC <sup>1)</sup>	Pick-up Voltage VDC max <sup>1)</sup>	Drop-out Voltage VDC min <sup>1)</sup>	Max. Voltage VDC * <sup>2)</sup>	Coil Resistance Ω
5	3.75	0.5	6.5	20.8 x (1±10%)
6	4.5	0.6	7.8	30 x (1±10%)
12	9	1.2	15.6	120 x (1±10%)
24	18	2.4	31.2	480 x (1±10%)
48	36	4.8	62.4	1920 x (1±10%)

### Sensitive type

Nominal Voltage VDC <sup>1)</sup>	Pick-up Voltage VDC max <sup>1)</sup>	Drop-out Voltage VDC min <sup>1)</sup>	Max. Voltage VDC * <sup>2)</sup>	Coil Resistance Ω
5	3.75	0.5	6.5	27.8 x (1±10%)
6	4.5	0.6	7.8	40 x (1±10%)
12	9	1.2	15.6	160 x (1±10%)
24	18	2.4	31.2	640 x (1±10%)
48	36	4.8	62.4	2560 x (1±10%)

**Notes:** 1)The data shown above are initial values.

2)\*Maximum voltage refers to the maximum voltage which relay coil could endure in a short period of time.



HONGFA RELAY

ISO9001, IATF16949, ISO14001, ISO45001, IECQ QC 080000, ISO/IEC 27001 CERTIFIED

2026 Rev. 1.00

## SAFETY APPROVAL RATINGS

UL/CUL TÜV	Standard type	Resistance load 50A 250VAC 65°C (AgNi/AgSnO <sub>2</sub> ) Resistance load 40A 250VAC 85°C (AgSnO <sub>2</sub> ) Resistance load 32A 250VAC 105°C (AgSnO <sub>2</sub> ) Resistance load Making 20A Carrying 60A Breaking 20A 277VAC 60°C (AgSnO <sub>2</sub> ) Resistance load 24VDC 30A 85°C (AgSnO <sub>2</sub> ) Resistance load Making 50A Breaking 10A 277VAC 85°C (Plastic sealed AgSnO <sub>2</sub> )
	Sensitive type	Resistance load Making 60A Breaking 20A 400VAC 85°C (AgSnO <sub>2</sub> )
CQC	Standard type	32A 277VAC 105°C (AgNi/AgSnO <sub>2</sub> ) 50A 277VAC 65°C (AgSnO <sub>2</sub> ) Resistance load Making 50A Breaking 10A 277VAC 85°C (Plastic sealed AgSnO <sub>2</sub> )
	Sensitive type	Resistance load Making 60A Breaking 20A 400VAC 85°C (AgSnO <sub>2</sub> )

Notes: 1) All values unspecified are at room temperature.

2) Only typical loads are listed above. Other load specifications can be available upon request.

## ORDERING INFORMATION

Type	HF165F-50 /	12	-H	L	T	(XXX)
Coil voltage	5, 6, 12, 24, 48VDC					
Contact arrangement	H: 1 Form A					
Coil power	L: Sensitive		Nil: Standard			
Contact material <sup>2)</sup>	T: AgSnO <sub>2</sub>		3: AgNi			
Special code <sup>3)</sup>	XXX: Customer special requirement		Nil: Standard		310: Plastic sealed	

Notes: 1) Please avoid using the relay in an environment containing organic silicon, otherwise the entry of organic silicon into the relay may accelerate contact failure. If there are harmful substances and elements such as water vapor, H<sub>2</sub>S, SO<sub>2</sub>, NO<sub>2</sub>, Cl, P, etc. in the use of environmental gases, it may lead to increased contact resistance and poor contact during the use of relays. In the above situations, please control the materials or use plastic sealed type and arrange relevant tests to confirm..

2) When there is surge current in the load, it is recommended to use AgSnO<sub>2</sub> contact material and confirm it in actual use.

3) The customer special requirement express as special code after evaluating by Hongfa. (A21) indicates that the maximum current carrying capacity of the product is 60A, (335) stands for product in accordance to IEC 60335-1(GWT).

4) Water cleaning or surface process is not suggested after the flux-proofed relays are assembled on PCB.

## OUTLINE DIMENSIONS, WIRING DIAGRAM AND PC BOARD LAYOUT

Unit: mm

### Outline Dimensions

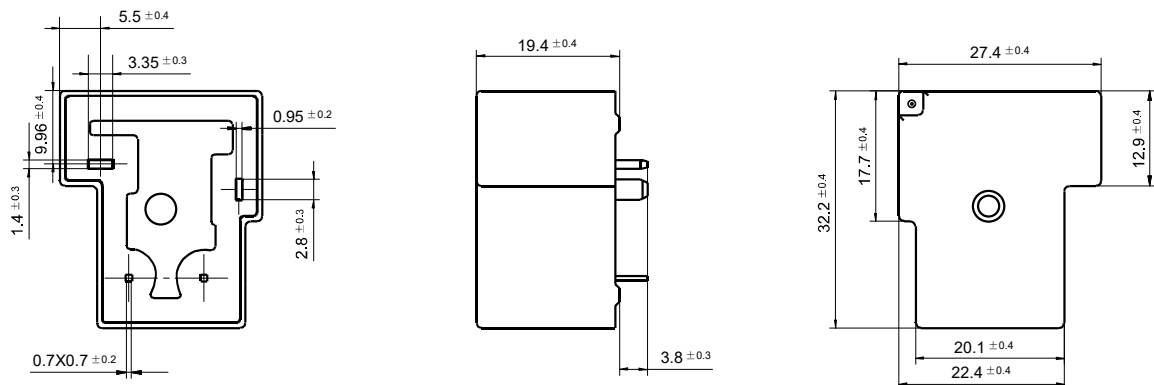

# OUTLINE DIMENSIONS, WIRING DIAGRAM AND PC BOARD LAYOUT

Unit: mm

PCB Layout (Bottom view)

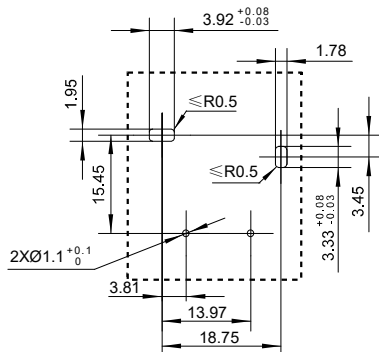

Wiring Diagram

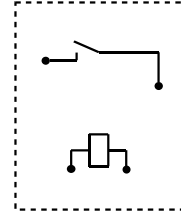

- Notes:** 1) In case of no tolerance shown in outline dimension: outline dimension  $\leq 1$ mm, tolerance should be  $\pm 0.2$ mm; outline dimension  $> 1$ mm and  $\leq 5$ mm, tolerance should be  $\pm 0.3$ mm; outline dimension  $> 5$ mm, tolerance should be  $\pm 0.4$ mm.  
2) The tolerance without indicating for PCB layout is always  $\pm 0.1$ mm.

## Disclaimer

The specification is for reference only. See to "Terminology and Guidelines" for more information. Specifications subject to change without notice. We could not evaluate all the performance and all the parameters for every possible application. Thus the user should be in a right position to choose the suitable product for their own application. If there is any query, please contact Hongfa for the technical service. However, it is the user's responsibility to determine which product should be used only.

© Xiamen Hongfa Electroacoustic Co., Ltd. All rights of Hongfa are reserved.