

Motor Control and Protection Components

HFUC3-06N...38N AC Contactors



INTRODUCTION

Hongfa, (Shanghai Stock Exchange: 600885), founded in 1984, has been adhering to the enterprise spirit of “persevere for progress, strive for excellence”, and has built a complete industry system with complete categories and supporting facilities. At present, Hongfa has more than 30 subsidiaries and has established three districts of R & D and production bases. Its products cover various categories, such as medium and low voltage products, relays, high and low voltage switchgear, capacitors, precision parts and automation equipment.

Xiamen Hongfa Electrical Safety & Controls Co., Ltd. is a wholly-owned subsidiary of Hongfa, which specializes in R & D, design and manufacture medium and low voltage products. Its distribution apparatus, terminal apparatus, control apparatus and other products are widely used in real estate, electric power, new energy, industry, HVAC, transportation, information and other fields.

In the United States, Europe, Southeast Asia and other regions, Hongfa has established localized marketing and service networks with global market operation and technical service. Relying on professional and rigorous technical support, fast response and all-round service, safe and reliable product quality and high cost performance, Hongfa has reached business cooperation relationship with many global top 500 enterprises and other well-known enterprises, such as Enel, GE, Honeywell, Carrier, Trane, Johnson Controls, Danfoss, State Grid, China Southern Power Grid, CRRC, China Mobile, China Unicom, etc.



Sunban Industrial Park



Donglin Industrial Park



Haicang Industrial Park



Zhongjiang Industrial Park



Zhangzhou Industrial Park



Zhoushan Industrial Park



Xi'an Factory

In terms of technology R & D and manufacturing, taking the national enterprise technology center as the platform, Hongfa has set up postdoctoral research workstation, academician and expert workstation. Now it has developed into a leading scientific research and production base in the industry. From product development, mold manufacturing, parts manufacturing, automated product assembly and online testing, Hongfa has successfully built an integrated whole industry chain of medium and low voltage products. In terms of product testing, Hongfa testing center has passed the certification of VDE, UL, CNAS and other international organizations, and has complete testing and analysis equipment for low-voltage products, such as 50kA ultimate short circuit test, 8kA electrical life test, 80kA characteristic test, mechanical simulation and testing system, electro-magnetic simulation and testing system.

Hongfa always adheres to the policy of "focused on the market, winning through quality", and has a completed quality assurance system. Its products have passed UL / CUL, VDE, CQC, CCC and other international safety certification. In the process of quality management, Hongfa actively implements the advanced quality concept, constantly improves the quality management system, continuously promotes the product process quality control and testing, strengthens the supply chain management, and is committed to providing each customer with high-quality products and creating greater value.

Advanced technology and strict quality control have created Hongfa's brand strength. Hongfa is willing to work hand in hand with global customers to share the convenience and well-being brought by science and technology.

CONTENT

HFUC3-06N...38N AC Contactors

01

Product Overview

05

02

Ordering Information

06

03

Technical Data

08

04

Accessories

13

05

Dimensions

15

06

Circuit Diagram

17

07

Reference Selection Table

18

08

Information for Use

21

NOTE:

The contents and data in this catalogue are not binding. We reserve the right to modify the contents of this document on the basis of technical development of the products, without prior notice. Starting from May 2025, we will initiate the transition from old to new product models (old model: UEC3..., new model: HFUC3...). Please order the new model HFUC3... according to the sample. The real order requirements and technical agreements shall prevail.

HFUC3 series

HFUC3-06N...38N AC Contactors

Product Overview

The HFUC3-06N...38N AC contactors range to a rated current of 6A...38A under the utilization category AC-3 and can be driven by both 50Hz and 60Hz. They can be combined with a thermal overload protection.

Product Features

- The product adopts high-performance silver alloy contacts, with a long electrical life.
- Wide range of operating voltage and reliable operation though there' s grid voltage fluctuation.
- H-grade high-temperature resistant enameled wire, with more durable coils.
- The coil supports up and down wire entry, meeting various wiring needs of customers.
- Buffer optimization, less noise of electromagnetic system.
- By installing the top dust cover and side dust stickers, the dust prevention is better.
- Product miniaturization design, smaller volume.





Design Features

- Modular accessories like auxiliary contact block, thermal overload relay, etc., can be equipped to meet different applications.
- The main contacts and auxiliary contacts are designed in the same layer to reduce the structure height and save installation space.
- The coil wiring can be either on the same side or on the opposite side, which is convenient for maintenance.
- The installation method can be 35mm DIN rail installation or screw installation, and the installation dimension is compatible with the products of the same category.

Typical Applications

Machinery, manufacturing control, elevator, chemical industry, power management, air conditioning compressor, water pump, conveyor belt, lighting control, heater, and electric vehicles.

Approval Certificate

	CCC	GB/T 14048.4, GB/T 14048.5
	CE	EN 60947-4-1, EN 60947-5-1
	UKCA	BS EN 60947-4-1, BS EN 60947-5-1
	TÜV	EN 60947-4-1, EN 60947-5-1
	UL (cULus LISTED)	UL 60947-4-1, UL 60947-5-1 CSA C22.2 No. 60947-4-1, CSA C22.2 No. 60947-5-1

Ordering Information

HFUC3 Contactors				
	HFUC	3	- 06	N 10 M7
Contactor series				
Design series number				
Rated operational current at rated operational voltage 400V under AC-3 category 06: 6A 09: 9A 12: 12A 18: 18A 32: 32A 38: 38A				
Product structure N: N type				
Number of built-in auxiliary NO contacts/NC contacts 10: 1NO 01: 1NC				
Coil control voltage (AC supply - 50/60Hz) B7: 24V F7: 110V CC7: 36V M7: 220-230 V E7: 48V Q7: 380V				
* Other coil versions on request				
Special product code No code (Blank): Standard type -098: Dustproof contactor				

CA1 Auxiliary Contact Blocks				
	CA	1	R	22
Auxiliary contact block				
Design series number				
Mounting type R: Top mounting S: Side mounting				
Number of auxiliary NO contacts/NC contacts 1) CA1R (2P) and CA1S: 11: 1NO+1NC 20: 2NO 02: 2NC 2) CA1R(4P): 22: 2NO+2NC 40: 4NO 31: 3NO+1NC 13: 1NO+3NC 04: 4NC				

Ordering Information

CA1M Mechanical Interlock Block

	CA	1	M	38
Contactory accessory				
Design series number				
Module type				
M: Mechanical interlock without integral electrical interlocking				
Suitable for contactor current range				
38: Suitable for 6A...38A				

CA1U Suppressor Module

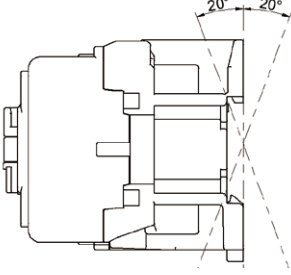

	CA	1	U	RC	2	G	AC
Contactory accessory							
Design series number							
Module type							
U: Suppressor module							
Protection type							
RC: RC circuits (Resistor-Capacitor) V: Varistors (Peak limiting)							
Installation type							
2: Fix with screw							
Suitable for coil voltage range							
E: 24-48 V G: 50-127 V U: 110-250 V N: 380-440 V							
Coil voltage type							
AC: AC supply (Just for RC circuits) AD: AC or DC supply (Just for Varistors)							

Technical Data

Parameters		Model	HFUC3-06N	HFUC3-09N	HFUC3-12N	HFUC3-18N	HFUC3-32N	HFUC3-38N
Operating environment								
Rated insulation voltage U_i		V	690					
Rated impulse withstand voltage U_{imp}		kV	6					
Conforming to standards			GB/T 14048.4, GB/T 14048.5, IEC/EN 60947-4-1, IEC/EN 60947-5-1, BS EN 60947-4-1, BS EN 60947-5-1, UL 60947-4-1, UL 60947-5-1, CSA C22.2 No. 60947-4-1, CSA C22.2 No. 60947-5-1					
Certifications			CCC, CE, UKCA, TÜV, UL (cULus LISTED)					
Degree of protection (front only)			Against direct finger contact: IP20					
Ambient air temperature	Storage	°C	-60...+80					
	Operation	°C	-40...+60 (+60...+70, for operation at 1.0Us...1.1Us)					
Max. operating altitude without derating		m	3000					
Pollution degree			3					
Mounting category			III					
Mounting type			Screw or 35mm DIN rail					
Flame resistance			Current-carrying part: 850°C					
Operating position ⁽¹⁾			Vertical mounting ($\pm 20^\circ$) 					

Notes: ⁽¹⁾ The products should be installed in a place without strong shaking or vibration.









Technical Data

										
Model				HFUC3-06N	HFUC3-09N	HFUC3-12N	HFUC3-18N	HFUC3-32N	HFUC3-38N	
Parameters										
Power circuit, 3-pole contactors										
IEC	AC-3	I_e	400V	A	6	9	12	18	32	38
		Rated operational power	220V/230 V	kW	1.5	2.2	3	4	7.5	9
			380V/400 V	kW	2.2	4	5.5	7.5	15	18.5
			660V/690 V	kW	3	5.5	7.5	10	18.5	18.5
	AC-1	I_e	≤690V	A	20	20	25	32	50	50
Conventional thermal current I_{th}				A	20	20	25	32	50	50
UL CSA	1-phase motor rating	110–120 V	hp	1/2	1/2	3/4	1	2	3	
		200–208 V	hp	3/4	1	2	2	5	5	
		220–240 V	hp	1	1	2	3	5	5	
	3-phase motor rating	200–208 V	hp	2	2	3	5	10	10	
		220–240 V	hp	2	3	3	5	10	10	
		440–480 V	hp	5	5	7-1/2	10	20	20	
		550–600 V	hp	5	7-1/2	10	15	25	25	
	AC general use rating AC resistance rating		600 V	A	20	20	25	30	50	50
Built-in auxiliary contacts standard type				1NO or 1NC						
Max. electrical operating frequency AC-3/400V				cycles/h	1200				600	
Mechanical durability				10 ⁶ cycles	10				10	
Max. mechanical operating frequency				cycles/h	3600				3600	
Auxiliary contact blocks ⁽¹⁾				CA1R, CA1S						
Outline dimension W x H x D			mm	45×74×80				56×80×85.5		
Net weight				kg	0.31				0.38	

Note: ⁽¹⁾The max. total number of add-on NO and NC auxiliary contact is 4 besides the build-in auxiliary contact; if more add-on auxiliary contacts are required, please contact us for evaluation.

Parameters		Model	HFUC3-06N...18N				HFUC3-32N...38N				
Coil control circuit, a.c. supply											
Rated control voltage U_s 50Hz/60Hz		V	24V, 36V, 48V, 110V, 220-230V, 380V								
Control voltage range (+60°C)	Operating voltage		0.85 U_s ...1.1 U_s								
	Drop-out voltage		0.2 U_s ...0.75 U_s								
Average power consumption at 25°C (for reference)	Inrush	VA	70				75				
	Sealed	VA	9				10.5				
Operating time Between coil energization and	main NO contact	ms	12...22								
	auxiliary NO	ms	15...26								
	auxiliary NC	ms	4...19								
Operating time Between coil de-energization and	main NO contact	ms	4...22								
	auxiliary NO	ms	4...22								
	auxiliary NC	ms	12...32								
Built-in auxiliary contacts											
Max. rated operational voltage U_e		V	690								
Max. insulation voltage U_i		V	690								
Min. switching capacity	U_{min}	V	24								
	I_{min}	A	0.1								
A600 AC-15	Conventional enclosed thermal current I_{the}		A								
	Rated operational voltage U_e		V	120	240	380	480	500	600		
	Rated operational current I_e		A	6	3	1.9	1.5	1.4	1.2		
	Make apparent power VA rating		VA	7200							
	Break apparent power VA rating		VA	720							
P600 DC-13	Conventional enclosed thermal current I_{the}		A								
	Rated operational voltage U_e		V	125	250	-	400	500	600		
	Rated operational current I_e		A	1.1	0.55	-	0.31	0.27	0.2		
	Make apparent power VA rating		VA	138							
	Break apparent power VA rating		VA	138							

Technical Data

Parameters		Model	HFUC3-06N...18N	HFUC3-32N...38N
Power circuit connections				
Solid cable without cable end 	1 conductor	mm ²	1...4	1.5...10
	2 conductors	mm ²	1...4	2.5...10
Flexible cable without cable end 	1 conductor	mm ²	1...4	2.5...10
	2 conductors	mm ²	1...4	2.5...10
Flexible cable with cable end 	1 conductor	mm ²	1...4	1.5...10
	2 conductors	mm ²	1...2.5	1.5...6
Lugs 	L ≤	mm	8.1	12
	l >	mm	3.7	4.2
Connection capacity acc. to UL/CSA	1 conductor	AWG	18...10	16...8
	2 conductors	AWG	18...12	14...8
Screwdriver	Phillips screwdriver		N°2	
	Φ Slotted screwdriver		Φ 6	
Tightening torque		Nm	1.2	2.0
		lb.in	10.7	18
Coil circuit connections and Built-in auxiliary circuit connections				
Solid cable without cable end 	1 conductor	mm ²	1...4	
	2 conductors	mm ²	1...4	
Flexible cable without cable end 	1 conductor	mm ²	1...4	
	2 conductors	mm ²	1...4	
Flexible cable with cable end 	1 conductor	mm ²	1...4	
	2 conductors	mm ²	1...2.5	
Lugs 	L ≤	mm	8.1	
	l >	mm	3.7	
Connection capacity acc. to UL/CSA	1 conductor	AWG	18...12	
	2 conductors	AWG	18...12	
Screwdriver	Phillips screwdriver		N°2	
	Φ Slotted screwdriver		Φ 6	
Tightening torque		Nm	1.2	
		lb.in	10.7	

Technical Data

Electrical Durability

Selection table according to endurance

The breaking current (I_c) of AC-3 utilization catalogue is equal to the rated operational current of motor. The characteristic curve in the figure below shows the endurance of the main contact when the contactor is used for making and breaking three-phase (AC-3 $U_e \leq 400V$) inductive load.

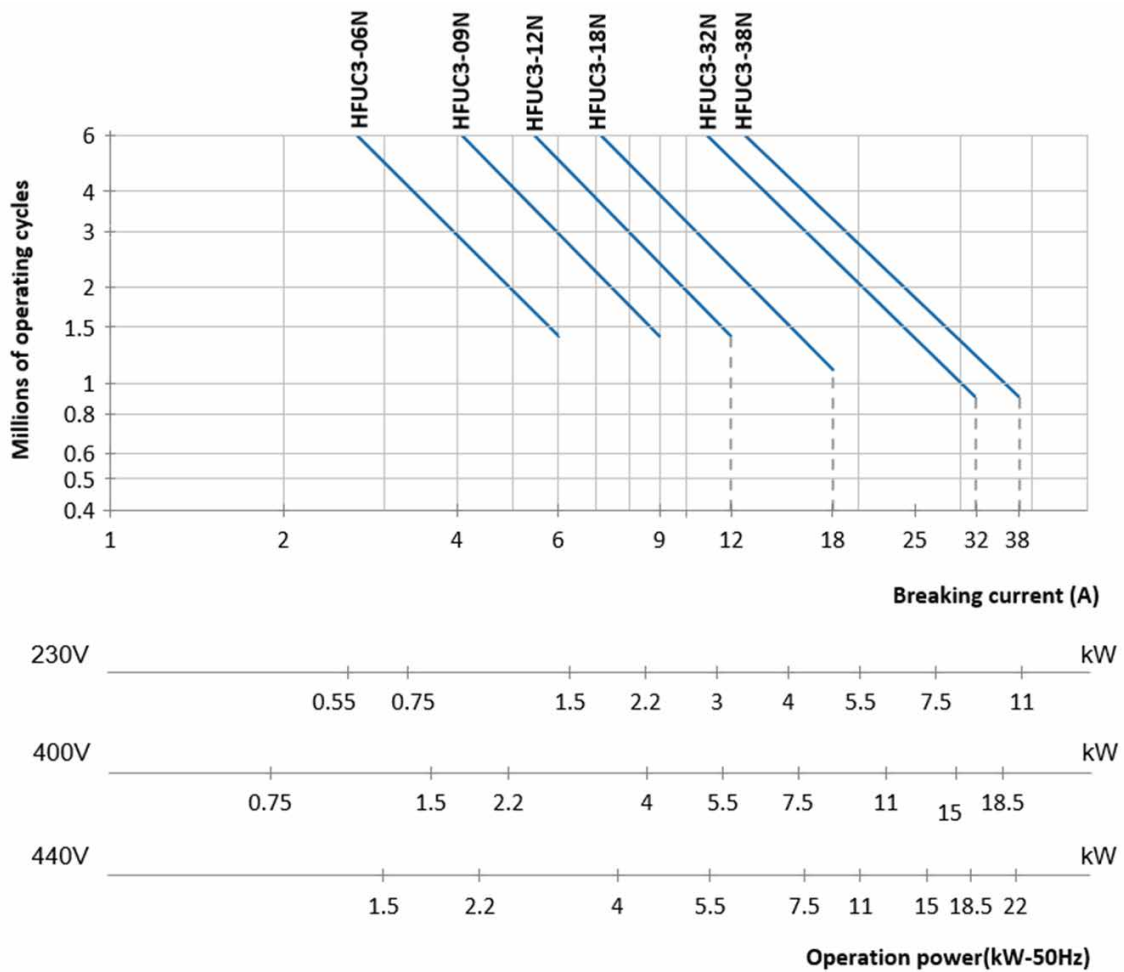

Example: Asynchronous motor: $P = 4kW$, $U_e = 400 V$, $I_e = 8.5 A$, $I_c = I_e = 8.5 A$

Or asynchronous motor: $P = 4kW$, $U_e = 415 V$, $I_e = 8.5 A$, $I_c = I_e = 8.5 A$

Need electrical endurance of 1.5 million cycles.



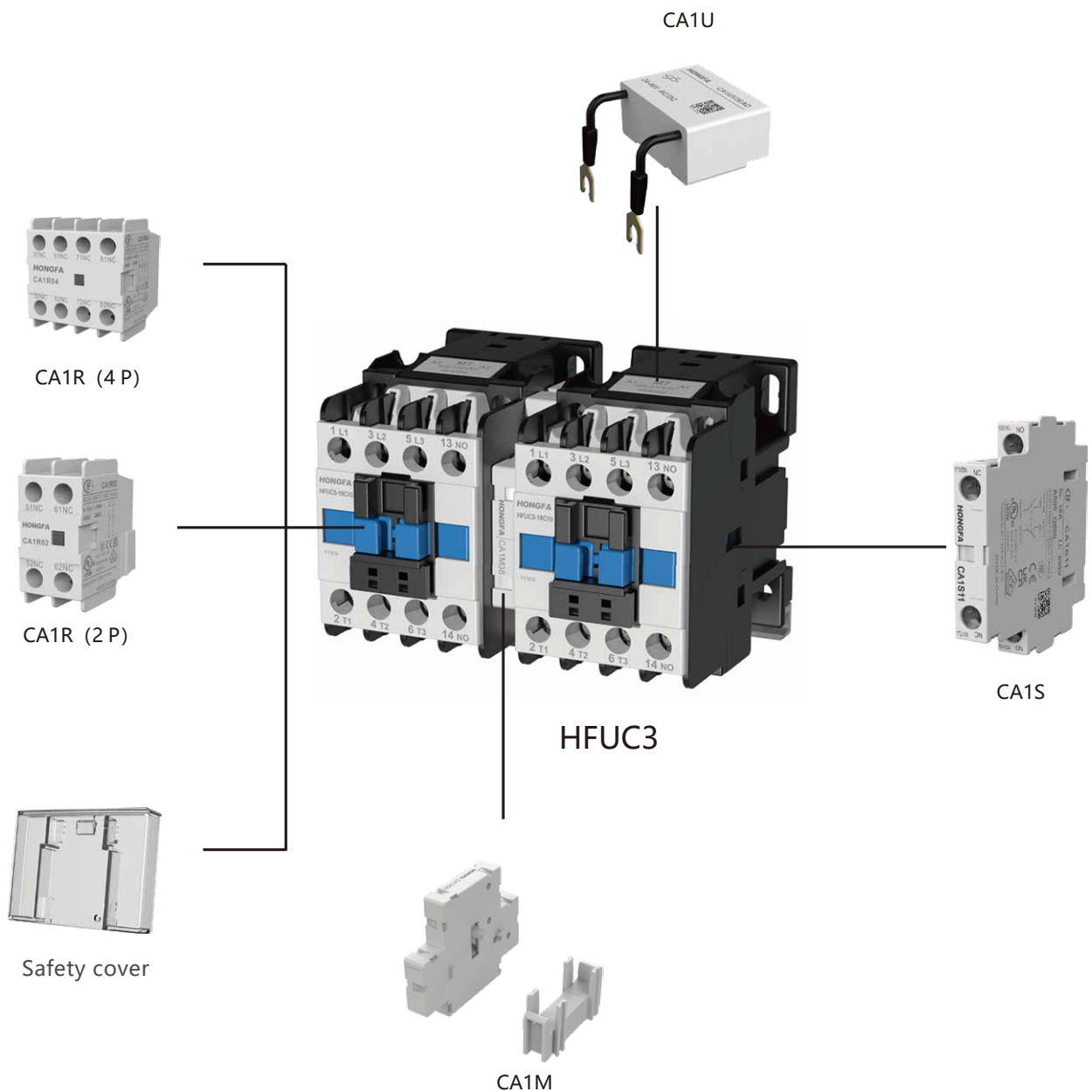

Above selective curve shows that the contactor part number is HFUC3-09N.

Accessories



Note: Safety cover is not sold separately, please contact the manufacturer for details.

Suppressor Module				
Parameters		Model	Varistors	RC circuits
			CA1UV2...	CA1URC2...
Ambient air temperature	Storage	°C	-60...+80	
	Operation	°C	-40...+70	
Max. operating altitude (without derating)		m	3000	
Suitable for coil voltage	50Hz/60Hz	V	24...440	
Increase in contactor operating time			delay 1.1 to 1.5 times	delay 1.2 to 2 times
For use with contactors			HFUC3-06...38	

Auxiliary Contact Blocks								
Parameters		Model	CA1R, CA1S					
Standards		GB/T 14048.5, IEC/EN 60947-5-1, BS EN 60947-5-1, UL 60947-5-1(CSA C22.2 No. 60947-5-1)						
Certifications		CCC, CE, UKCA, VDE, UL (cULus LISTED)						
Degree of protection		IP20						
Ambient air temperature	Storage	°C	-60...+80					
	Operation	°C	-40...+70					
Max. operating altitude without derating		m	3000					
Solid cable without cable end 	1 conductor	mm ²	1...4					
	2 conductors	mm ²	1...4					
Flexible cable without cable end 	1 conductor	mm ²	1...4					
	2 conductors	mm ²	1...4					
Flexible cable with cable end 	1 conductor	mm ²	1...4					
	2 conductors	mm ²	1...2.5					
Lugs 	L ≤	mm	8.1					
	L >	mm	3.7					
Connection capacity acc. to UL/CSA	1 conductor	AWG	18...12					
	2 conductors	AWG	18...12					
Screwdriver	Phillips screwdriver		N°2					
	Φ Slotted screwdriver		Φ6					
Tightening torque		Nm	1.2					
			lb.in					
Max. rated operating voltage U _e		V	690					
Max. insulation voltage U _i		V	690					
Min. switching capacity	U _{min}	V	24					
	I _{min}	A	0.1					
A600 AC-15	Conventional enclosed thermal current I _{the}	A	10					
	Rated operational voltage U _e	V	120	240	380	480	500	600
	Rated operational current I _e	A	6	3	1.9	1.5	1.4	1.2
	Make apparent power VA rating	VA	7200					
	Break apparent power VA rating	VA	720					
Q600 DC-13	Conventional enclosed thermal current I _{the}	A	2.5					
	Rated operational voltage U _e	V	125	250	-	400	500	600
	Rated operational current I _e	A	0.55	0.27	-	0.15	0.13	0.1
	Make apparent power VA rating	VA	69					
	Break apparent power VA rating	VA	69					
For use on contactors		HFUC3-06...38						

Dimensions

AC contactors:

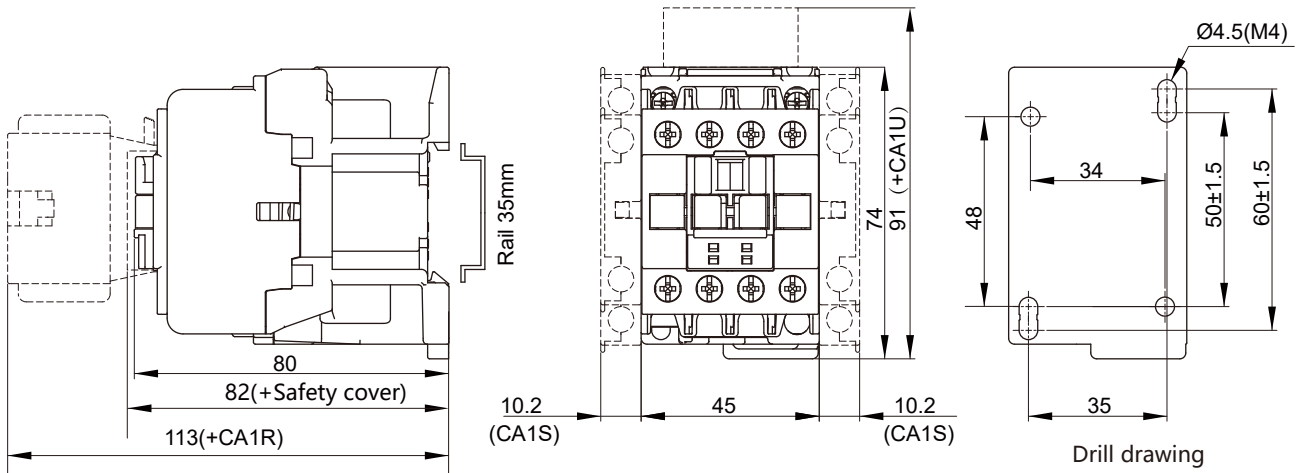

HFUC3-06N, HFUC3-09N, HFUC3-12N, HFUC3-18N

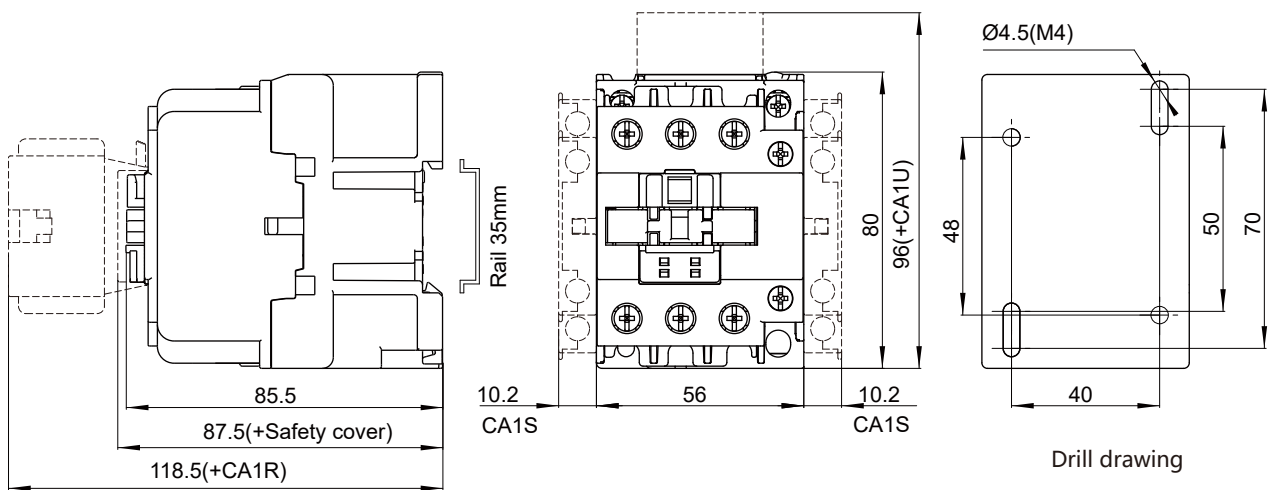

HFUC3-32N, HFUC3-38N

Interlock contactors:

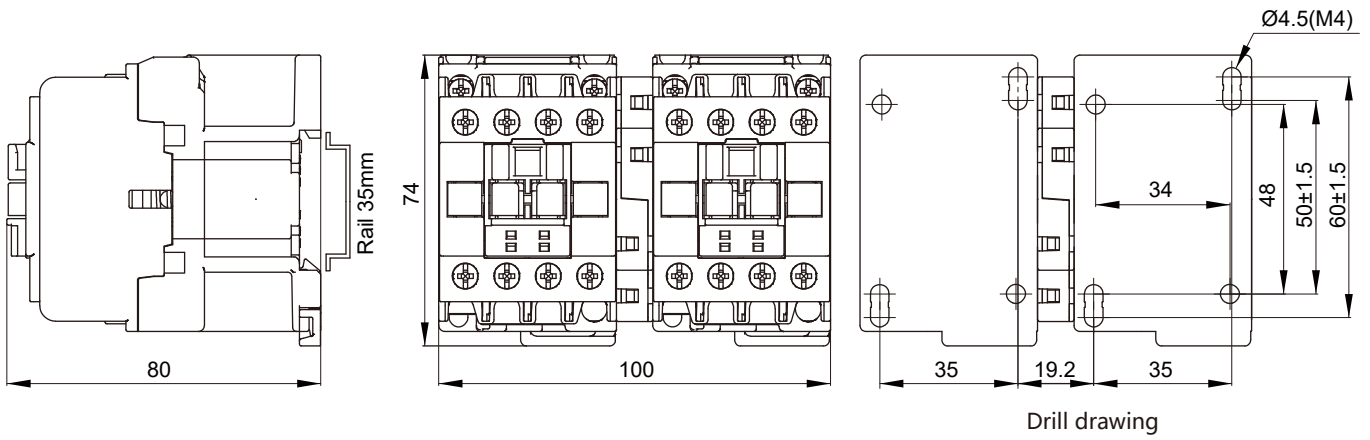

HFUC3-06N, HFUC3-09N, HFUC3-12N, HFUC3-18N + CA1M38

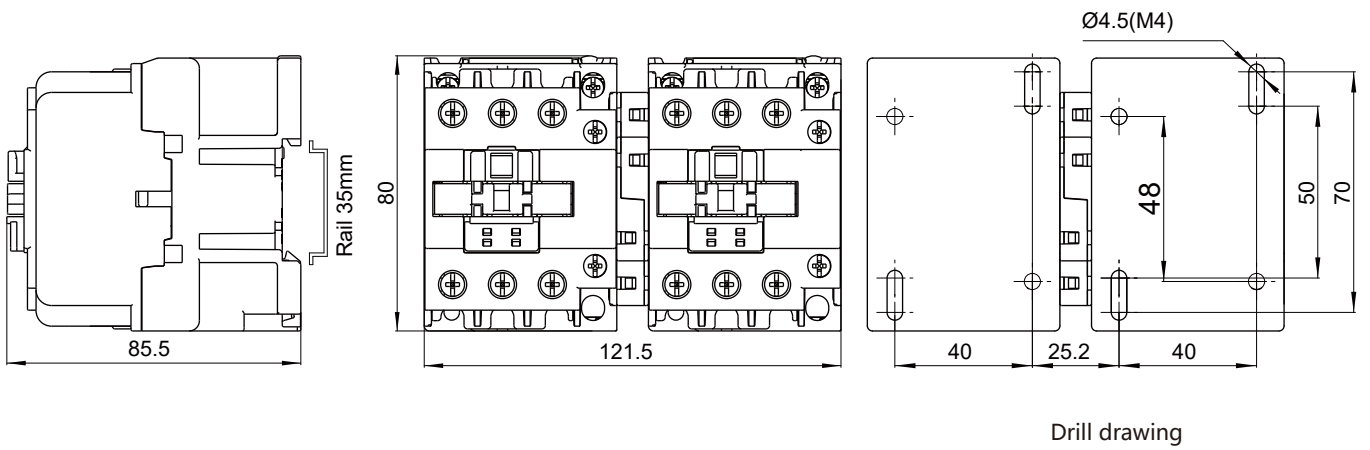

HFUC3-32N, HFUC3-38N + CA1M38

Note: The unit is mm. The tolerance for mounting holes: ±0.5; for other external dimensions: ± 1.5, unless otherwise specified.



Circuit Diagram

AC Contactor	
HFUC3-06N10 HFUC3-09N10 HFUC3-12N10 HFUC3-18N10 HFUC3-32N10 HFUC3-38N10	
HFUC3-06N01 HFUC3-09N01 HFUC3-12N01 HFUC3-18N01 HFUC3-32N01 HFUC3-38N01	



Top mounting CA1R		
CA1R11 (1NO1NC)	CA1R20 (2NO)	CA1R02 (2NC)
CA1R22 (2NO2NC)	CA1R31 (3NO1NC)	CA1R13 (1NO3NC)
CA1R40 (4NO)	CA1R04 (4NC)	

Side mounting CA1S		
CA1S11 (1NO1NC)	CA1S20 (2NO)	CA1S02 (2NC)

Reference Selection Table



AC Contactor											
IEC			UL/CSA			Number of poles	Built-in auxiliary contacts ⁽¹⁾		Coil control voltage ⁽²⁾	Type ⁽³⁾	Net weight (1 pc)
Standard power ratings of 3-phase motors 50Hz/60Hz in category AC-3 (θ≤60°C)		Rated operational current AC-3	3-phase motor rating		General use rating						
220 V 230 V	380 V 400 V	400 V	220 V 240 V	440 V 480 V	600 V				50Hz/60Hz		kg
kW	kW	A	hp	hp	A				V		
1.5	2.2	6	2	5	20	3	0	1	24	HFUC3-06N01B7	0.31
									110	HFUC3-06N01F7	
									220-230	HFUC3-06N01M7	
									380	HFUC3-06N01Q7	
									24	HFUC3-06N10B7	
									110	HFUC3-06N10F7	
									220-230	HFUC3-06N10M7	
									380	HFUC3-06N10Q7	
2.2	4	9	3	5	20	3	0	1	24	HFUC3-09N01B7	0.31
									110	HFUC3-09N01F7	
									220-230	HFUC3-09N01M7	
									380	HFUC3-09N01Q7	
									24	HFUC3-09N10B7	
									110	HFUC3-09N10F7	
									220-230	HFUC3-09N10M7	
									380	HFUC3-09N10Q7	
3	5.5	12	3	7-1/2	25	3	0	1	24	HFUC3-12N01B7	0.31
									110	HFUC3-12N01F7	
									220-230	HFUC3-12N01M7	
									380	HFUC3-12N01Q7	
									24	HFUC3-12N10B7	
									110	HFUC3-12N10F7	
									220-230	HFUC3-12N10M7	
									380	HFUC3-12N10Q7	
4	7.5	18	5	10	30	3	0	1	24	HFUC3-18N01B7	0.31
									110	HFUC3-18N01F7	
									220-230	HFUC3-18N01M7	
									380	HFUC3-18N01Q7	
									24	HFUC3-18N10B7	
									110	HFUC3-18N10F7	
									220-230	HFUC3-18N10M7	
									380	HFUC3-18N10Q7	

Reference Selection Table

AC Contactor											
IEC		UL/CSA				Number of poles	Built-in auxiliary contacts ⁽¹⁾		Coil control voltage ⁽²⁾	Type ⁽³⁾	Net weight (1 pc)
Standard power ratings of 3-phase motors 50Hz/60Hz in category AC-3 (θ≤60°C)		3-phase motor rating		General use rating							
220V 230V	380V 400V	400V	220 V 240 V	440 V 480 V	600 V				50Hz/60Hz		
kW	kW	A	hp	hp	A				V		kg
7.5	15	32	10	20	50	3	0	1	24	HFUC3-32N01B7	0.38
									110	HFUC3-32N01F7	
									220-230	HFUC3-32N01M7	
									380	HFUC3-32N01Q7	
							1	0	24	HFUC3-32N10B7	
									110	HFUC3-32N10F7	
									220-230	HFUC3-32N10M7	
									380	HFUC3-32N10Q7	
9	18.5	38	10	20	50	3	0	1	24	HFUC3-38N01B7	0.38
									110	HFUC3-38N01F7	
									220-230	HFUC3-38N01M7	
									380	HFUC3-38N01Q7	
							1	0	24	HFUC3-38N10B7	
									110	HFUC3-38N10F7	
									220-230	HFUC3-38N10M7	
									380	HFUC3-38N10Q7	

Coil control voltage (V) (50Hz/60Hz)	24	36	48	110	220-230	380
Coil control voltage code	B7	CC7	E7	F7	M7	Q7

Note: Coil control voltage codes are shown in the table above (other coil versions on request).

CA1 Auxiliary Contact Blocks						
Mounting type	Switching capacity	Auxiliary contacts ⁽¹⁾		Type ⁽³⁾	Net weight (1 pc)	
					kg	
Top mounting	A600 Q600	0	2	CA1R02	0.035	
		1	1	CA1R11		
		2	0	CA1R20		
		0	4	CA1R04		
		1	3	CA1R13		
		2	2	CA1R22		
		3	1	CA1R31		
4	0	CA1R40				
Side mounting		1	1	CA1S11	0.040	

CA1M Mechanical Interlock Block				
Mounting type	For use with contactors	Type	Net weight (1 pc) kg	
Side mounting	HFUC3-06...38	CA1M38	0.021	

CA1U Suppressor Module				
Mounting type	Protection type	Coil voltage range ⁽²⁾	Type ⁽³⁾	Net weight (1 pc) kg
Top mounting	Varistors	24-48V	CA1UV2EAD	0.016
		110-250V	CA1UV2UAD	
	RC circuits	24-48V	CA1URC2EAC	
		110-250V	CA1URC2UAC	

Notes: (1) All the above auxiliary contacts are all instantaneous auxiliary contacts.
(2) Please contact the sales company for specific coil voltage specifications.
(3) For other types, please refer to the details in page 06...07.

Information for Use

Altitude dependent compensation factor

- The rarefied atmosphere at high altitude reduces the dielectric strength of the air and hence the rated operational voltage of the contactor. It also reduces the cooling effect of the air and hence the rated operational current of the contactor (unless the temperature drops at the same time).
- At an altitude of less than 3000m, no significant effect on the performance of the product. When the altitude is above 3000m, conditions of air cooling and decrease of rated impulse withstand voltage must be considered, so the design and application need to be further communicated with manufacturer.

Correction coefficients of operational voltage and operational current when the altitude is above 3000m are described as below.

Altitude(m)	Rated operational voltage	Rated operational current
≤3500	0.90	0.92
≤4000	0.80	0.90
≤4500	0.70	0.88
≤5000	0.60	0.86

Technical parameter explanation

- Parameters contained in this catalogue such as electrical durability and mechanical durability are based on standard samples' test results, and the actual use may differ from these due to the difference of environment, operating frequency, devices etc.

Xiamen Hongfa Electroacoustic Co. Ltd

ADD: No.560-578, Donglin Rd., Jimei North Ind. Dist., Xiamen, China

TEL: +86-592-6106688

FAX: +86-592-6106678

E-mail: marketing@hongfa.com

Marketing & Sales Network

Hongfa Europe GmbH

ADD: Marie-Curie-Ring 26, D-63477
Maintal, Germany

TEL: +49-6181-4306-0

E-mail: info@hongfa-europe.com

Hongfa America, Inc.

ADD: 20381 Hermana Circle, Lake
Forest, CA92630, USA

TEL: +1-714-669-2888

E-mail: sales@hongfaamerica.com

KG Technologies, Inc.

ADD: 6028 Stat Farm Drive
Rohnert Park, CA 94928, USA

TEL: +1-888-513-1874

E-mail: info@kgtechnologies.com

Hongfa Electroacoustic (Hongkong) Co., Ltd.

ADD: Rm 1810-12, 18/F., Shatin Galleria,
18-24 Shan Mei St., Fotan, N.T, HongKong

TEL: +852-2947-7889

E-mail: hongkong@hongfa.com

Shanghai Hongfa Electroacoustic Co., Ltd.

ADD: NO.51.341, Jiuxin Rd., Jiuting
Town, Songjiang Dist., Shanghai

TEL: +86-21-37693111

E-mail: shanghai@hongfa.com

Beijing Hongfa Electroacoustic Relay Co., Ltd.

ADD: 111Bldg, Phase IV Westside of Lian
-dong U Valley, Tongzhou Dist., Beijing

TEL: +86-10-56495556

E-mail: beijing@hongfa.com

Sichuan Hongfa Relay Co., Ltd.

ADD: 12F, Hongfa Building, No.6 Wuxing 4th
Road, Wuhou District, Chengdu

TEL: +86-28-86627550

E-mail: sichuan@hongfa.com

Hongfa India Branch

TEL: +86-592-6196714

E-mail: power-sa@hongfa.com

TEL: +91-9971187792

E-mail: rohit@hongfa.com

Hongfa Philippine Branch

TEL: +63-9177189352

E-mail: nia-videna@hongfa.com

Hongfa Korea Branch

ADD: Sanggadong 203, 24, Cheonghak-ro
68beon-gil, Byeollae-myeon,
Namyangju-si, Gyeonggi-do,
Republic of Korea

TEL: +82-10-8704-4706

E-mail: khlee@hongfa.com

Hongfa Brazil Branch

Non-automotive relay project

TEL: +86-592-6196714

E-mail: southamerica@hongfa.com

Automotive relay project

TEL: +86-592-6196751

E-mail: auto-asia3@hongfa.com

Hongfa Turkey Branch

TEL: +90-535-0221881

E-mail: info-turkey@hongfa.com

The relevant information on the products contained is for reference only.
For details, please consult our business staff.

August 2025

Headquarter's Marketing & Sales Center

ADD: No.566-578, Donglin Rd., Jimei North Ind. Dist., Xiamen

E-mail: marketing@hongfa.com

SALES SERVICE HOTLINE

400-600-1502



HONGFA GROUP



HONGFA ELECTRIC