

Specifications



DP Contactor ,XMC0-323A, 2P (2NO), AC Coil

Main

Product Series	XMC0	
Product or Component Type	Definite Purpose Contactors	
Device Short Name	XMC0-323A	
Contact Application	HVAC, refrigeration, heating, data processing, welding, elevators, hoist & cranes, pool, commercial spa, and food service equipment industries, etc.	
Poles Description	2P (3P Frame)	
Rated Operational Voltage [Ue]	Power circuit: ≤ 600 V AC 50/60Hz	
Full Load Ampere [FLA]	32 A	
Locked Rotor Ampere [LRA]	180 A @ 240/277 V AC; 150 A @ 480 V AC; 120 A @ 600 V AC	
Resistive Ampere [RES]	40 A	
Control Circuit Voltage [Us]	Code	Voltage
	E	24 V AC 50/60Hz
	F	110-120 V AC 50/60Hz
	I	208-220 V AC 50Hz 208-240 V AC 60Hz
	L	277 V AC 60Hz
	N	380-415 V AC 50Hz 440-480 V AC 60Hz
Main Contact Terminals	C type: Slotted & Hex head washer w/ quick connect D type: Box Lug w/ quick connect E type: Box lug w/ quick connect (Line side) Slotted & Hex head washer w/ quick connect (Load side) F type: Slotted & Hex head washer w/ quick connect (Line side) Box lug w/ quick connect (Load side)	



C type on 25-40A FLA
#10-32 combination
Phillips, slotted & 5/16 hex head
with #8 washer

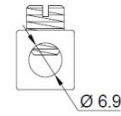

D type on 25-40A FLA
#14-4 AWG Cu/Al

Coil Terminals

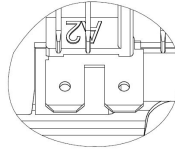

Dual QC

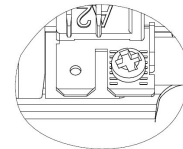

Single QC w/ screw

Complementary

Maximum Horse Power Rating	5 hp 240/277 V AC, 1phase
Pole Contact Composition	2 NO
Pollution Degree	3
Control Circuit Voltage Limits @ 25°C (Cold state)	0.8...1.1 Us: operational AC 50/60 Hz 0.2...0.75 Us: drop-out AC 50/60 Hz
Nominal Inrushed VA @ 25°C (Cold state)	E: 55 VA @ 24V 50 Hz, 50 VA @ 24V 60Hz F: 65 VA @ 120V 50 Hz, 60 VA @ 120V 60Hz I: 45 VA @ 220V 50 Hz, 50 VA @ 240V 60Hz L: 50 VA @ 277V 60Hz N: 45 VA @ 415V 50 Hz, 60 VA @ 480V 60Hz
Nominal Sealed VA @ 25°C (Cold state)	E: 10 VA @ 24V 50 Hz, 8 VA @ 24V 60Hz F: 13.5 VA @ 120V 50 Hz, 10 VA @ 120V 60Hz I: 9.5 VA @ 220V 50 Hz, 9.5 VA @ 240V 60Hz L: 10.5 VA @ 277V 60Hz N: 12 VA @ 415V 50 Hz, 13 VA @ 480V 60Hz
Maximum Operating Rate	Electrical: 360 cycs/h Mechanical: 3600 cycs/h
Tightening Torque	Power circuit: 25 lb-in - on screw terminals Power circuit: 25 lb-in - on box lug terminals Control circuit: 8 lb-in
Auxiliary Contact Composition	W/o built-in auxiliary contacts. Additional auxiliary contact modules can be installed if needed.
Mounting Support	Screw
A2L application:	Suffix w/ "W": Flame Arrest-protected Components for Use in Refrigeration and Air-conditioning Equipment Employing A2L Refrigerants.
Minimum Switching Load	110 VAC, 1A

Environment

Standards	UL 60947-4-1, GB/T 14048.4, IEC 60947-4-1, EN 60947-4-1
-----------	---

Product Certifications	UL, CCC, TÜV
------------------------	--------------

Permissible Ambient Air	-40 °C...70 °C (-40 °F...158 °F) for normal operating
-------------------------	---

Temperature Around the Device	-40 °C...70 °C (-40 °F...158 °F) for storage
-------------------------------	--

Height	95 mm
--------	-------

Width	60.2 mm
-------	---------

Depth	75 mm
-------	-------

Net Weight	0.415 kg
------------	----------

Packing Units

Unit Type of Package (bulk package)	1 carton
-------------------------------------	----------

Number of Units in Package	30 pcs
----------------------------	--------

Package Height	215 mm
----------------	--------

Package Width	340 mm
---------------	--------

Package Length	360 mm
----------------	--------

Package Weight	13.45 kg
----------------	----------

Offer Sustainability

REACH Regulation	Conforming
------------------	------------

EU RoHS Directive	Conforming
-------------------	------------

Mercury Free	Yes
--------------	-----

China RoHS Regulation	Conforming
-----------------------	------------

RoHS Exemption Information	Yes
----------------------------	-----

Contractual Warranty

Warranty	18 months
----------	-----------

Dimensions

XMC0 2P (3P Frame) 25-40A (2NO)

AC Contactor:

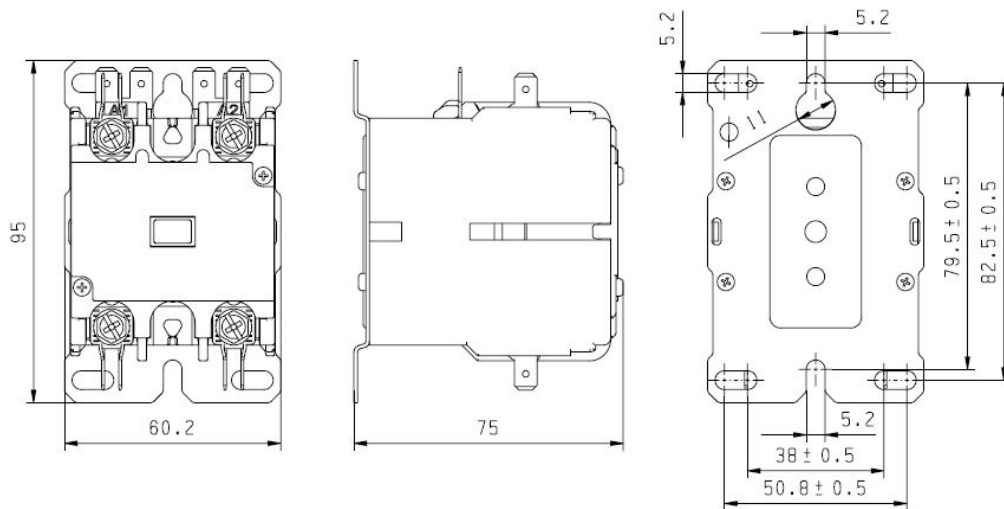

Note: The unit is mm. The tolerance for mounting holes: ± 0.5 ; for other external dimensions: ± 1.5 , unless otherwise specified.

Wiring Diagram

