

Thermal Overload Relays

UER1 series



INTRODUCTION

Hongfa, (Shanghai Stock Exchange: 600885), founded in 1984, has been adhering to the enterprise spirit of “persevere for progress, strive for excellence”, and has built a complete industry system with complete categories and supporting facilities. At present, Hongfa has more than 30 subsidiaries and has established three districts of R & D and production bases. Its products cover various categories, such as medium and low voltage products, relays, high and low voltage switchgear, capacitors, precision parts and automation equipment.

Xiamen Hongfa Electrical Safety & Controls Co., Ltd. is a wholly-owned subsidiary of Hongfa, which specializes in R & D, design and manufacture medium and low voltage products. Its distribution apparatus, terminal apparatus, control apparatus and other products are widely used in real estate, electric power, new energy, industry, HVAC, transportation, information and other fields.

In the United States, Europe, Southeast Asia and other regions, Hongfa has established localized marketing and service networks with global market operation and technical service. Relying on professional and rigorous technical support, fast response and all-round service, safe and reliable product quality and high cost performance, Hongfa has reached business cooperation relationship with many global top 500 enterprises and other well-known enterprises, such as Enel, GE, Honeywell, Carrier, Trane, Johnson Controls, Danfoss, State Grid, China Southern Power Grid, CRRC, China Mobile, China Unicom, etc.



Sunban Industrial Park



Donglin Industrial Park



Haicang Industrial Park

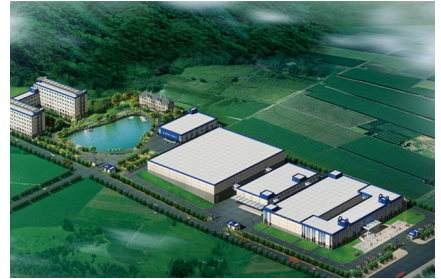

Zhongjiang Industrial Park



Zhangzhou Industrial Park



Zhoushan Industrial Park



Xi'an Factory

In terms of technology R & D and manufacturing, taking the national enterprise technology center as the platform, Hongfa has set up postdoctoral research workstation, academician and expert workstation. Now it has developed into a leading scientific research and production base in the industry. From product development, mold manufacturing, parts manufacturing, automated product assembly and online testing, Hongfa has successfully built an integrated whole industry chain of medium and low voltage products. In terms of product testing, Hongfa testing center has passed the certification of VDE, UL, CNAS and other international organizations, and has complete testing and analysis equipment for low-voltage products, such as 50kA ultimate short circuit test, 8kA electrical life test, 80kA characteristic test, mechanical simulation and testing system, electro-magnetic simulation and testing system.

Hongfa always adheres to the policy of "focused on the market, winning through quality", and has a completed quality assurance system. Its products have passed UL / CUL, VDE, CQC, CCC and other international safety certification. In the process of quality management, Hongfa actively implements the advanced quality concept, constantly improves the quality management system, continuously promotes the product process quality control and testing, strengthens the supply chain management, and is committed to providing each customer with high-quality products and creating greater value.

Advanced technology and strict quality control have created Hongfa's brand strength. Hongfa is willing to work hand in hand with global customers to share the convenience and well-being brought by science and technology.

CONTENT

UER1 Thermal Overload Relays

01	Product Overview	05
02	Ordering Information	06
03	Technical Data	07
04	Dimensions	09
05	Circuit Diagram	12
06	Tripping Curve	13
07	Reference Selection Table	15

UER1 Thermal Overload Relays



Product Overview

The UER1 thermal overload relays range up to an insulation voltage of 690V and an operational voltage of 690V, and can be driven by both 50Hz and 60Hz. They can provide current overload protection and phase loss protection, and the setting current is adjustable(0.1...336A). They are also with the function of temperature compensation, action indication, automatic and manual reset and stop, etc.

Product Features

- Temperature self-compensation design can adjust the compensation to improve the reliability of products.
- Auxiliary contact design of 1NO + 1NC can be used for the control of two different power sources.
- With manual reset and automatic reset switching button, easy for switching.

Approval Certificate

	CCC	GB/T 14048.4, GB/T 14048.5
	CE	EN 60947-4-1, EN 60947-5-1
	UKCA	BS EN 60947-4-1, BS EN 60947-5-1

Product Appearance

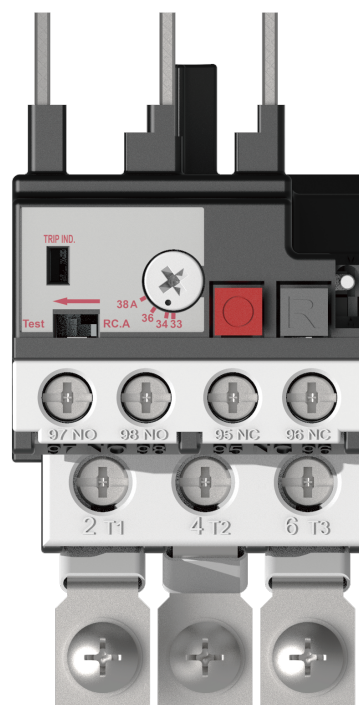

Ordering Information





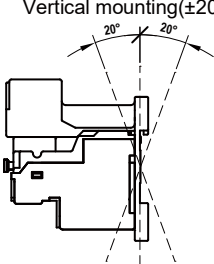

UER	1	- 40	/ 0.16	A	Z
Thermal overload relays					
Design number					
Reference code					
40: Setting current 0.1...38A					
90: Setting current 17...97A					
330: Setting current 87...336A					
Code for the current setting range: See Table 1					
Function					
A: Three phase overload protection and phase loss protection					
B: Three phase overload protection					
Mounting method					
Z: Combined mounting (Direct mounting on contactor) (Except for UER1-330)					
D: Independent mounting					

Table 1

UER1 Reference	Code for the current setting range			UER1 Reference	Code for the current setting range			
	Code	Current setting range A	Coordinate with contactors		Code	Current setting range A	Coordinate with contactors	
UER1-40	0.16	0.1...0.16	UEC1-09...38	UER1-40	20	15...20	UEC1-18...38	
	0.25	0.16...0.25			21.5	17.5...21.5	UEC1-25...38	
	0.4	0.25...0.4			25	21...25		
	0.5	0.35...0.5			30	24.5...30	UEC1-32...38	
	0.63	0.45...0.63			36	29...36	UEC1-38	
	0.8	0.55...0.8			38	33...38		
	1.0	0.75...1.0		UER1-90	25	17...25	UEC1-40...95	
	1.3	0.9...1.3			36	24.5...36		
	1.6	1.1...1.6			47	35...47	UEC1-50...95	
	2.0	1.4...2.0			60	45...60	UEC1-65...95	
	2.5	1.8...2.5			75	58...75	UEC1-80...95	
	3.2	2.3...3.2			90	72...90	UEC1-95	
	4.0	2.9...4.0			97	77...97		
	4.8	3.5...4.8			UER1-330	120	87...120	Independent mounting
	6.3	4.5...6.3				144	105...144	
	7.5	5.5...7.5				200	145...200	
10	7.2...10	240	175...240					
12.5	9...12.5	UEC1-12...38	280	203...280				
16	11.3...16	UEC1-18...38	336	245...336				

Technical Data

Parameters		Type	UER1-40		UER1-90			UER1-330
			Code<30	Code≥30	Code<60	Code≥60		
Operating environment								
Rated insulation voltage U		V	690		690			690
Rated impulse withstand voltage U _{im}		kV	6		6			6
Tripping class			10A					
Degree of protection (front only)			IP20	IP20 (except for external terminals)	IP20	IP20 (except for external terminals)		IP20
Ambient air temperature	Storage	°C	-40...+70					
	Operation	°C	-5...+60					
Pollution degree			3					
Mounting type	Combined mounting		Plug connect with AC contactor					
	Independent mounting		Screw or 35mm DIN rail					
Max. operating altitude (No derating) (m)			2000					
Flame resistance			Current-carrying part: 850°C					
Operating position			Vertical mounting(±20°) 					
Built-in auxiliary contacts								
Number of auxiliary contacts			1NO+1NC					
Highest rated operation voltage U _e		V	690					
Rated insulation voltage U _i		V	690					
Min. switching capacity	U _{min}	V	17					
	I _{min}	mA	5					
Conventional enclosed thermal current I _{the}		A	10					
A600	Rated operational voltage U _e	V	120	240	380	480	500	600
	Rated operational current	A	6	3	1.9	1.5	1.4	1.2
AC-15	Make apparent power VA rating	VA	7200					
	Break apparent power VA rating	VA	720					
Conventional enclosed thermal current I _{the}		A	2.5					
Q300	Rated operational voltage U _e	V	120	240	-	-	-	-
	Rated operational current	A	0.55	0.27	-	-	-	-
DC-13	Make apparent power VA rating	VA	69					
	Break apparent power VA rating	VA	69					

Parameters	Type	UER1-40		UER1-90		UER1-330
		Code<30	Code≥30	Code<60	Code≥60	
Power circuit connections						
Solid cable without cable end 	1 conductor	mm ²	1...6	—	2.5...16	—
	2 conductors	mm ²				
Flexible cable without cable end 	1 conductor	mm ²	1...6	—	2.5...16	—
	2 conductors	mm ²				
Flexible cable with cable end 	1 conductor	mm ²	1...6	1...6	2.5...16	10...35
	2 conductors	mm ²				6...16
Screwdriver	Philips screwdriver		N° 2		N° 2	
	Φ Slotted screwdriver		Φ6		Φ6	Φ10
Tightening torque	Nm	2.2	2.5	4.5	7	15...21 ⁽¹⁾
Built-in auxiliary circuit connections						
Solid cable without cable end 	1 conductor	mm ²	1...2.5		1...2.5	1...2.5
	2 conductors	mm ²				
Flexible cable without cable end 	1 conductor	mm ²				
	2 conductors	mm ²				
Flexible cable with cable end 	1 conductor	mm ²				
	2 conductors	mm ²				
Lugs 	l mm≤		8.1		8.1	8.1
	l mm>		3.7		3.7	3.7
Screwdriver	Philip screwdriver		N° 2		N° 2	
	Φ Slotted screwdriver		Φ6		Φ6	Φ6
Tightening torque	Nm	1.2		1.2		1.2

Note: ⁽¹⁾ The power circuit of UER1-330 is connected with copper bars, and the specification of copper bars and fasteners and tightening torque above are reference values.

Dimensions

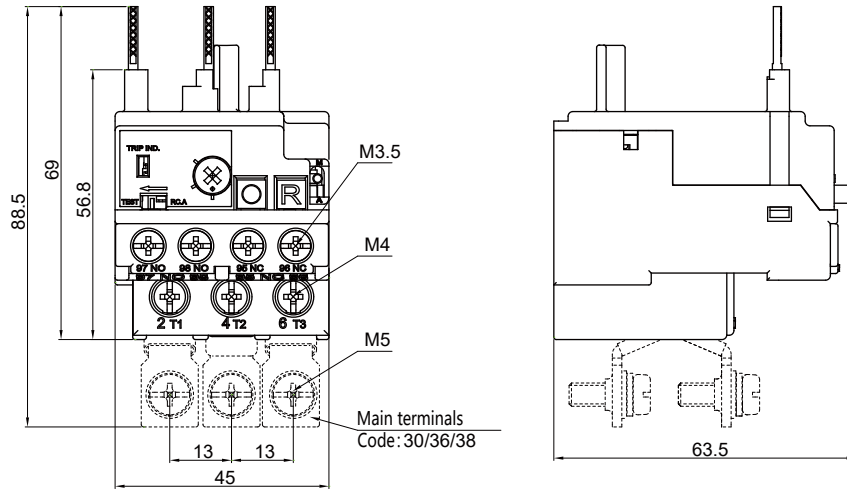

UER1-40/□□Z

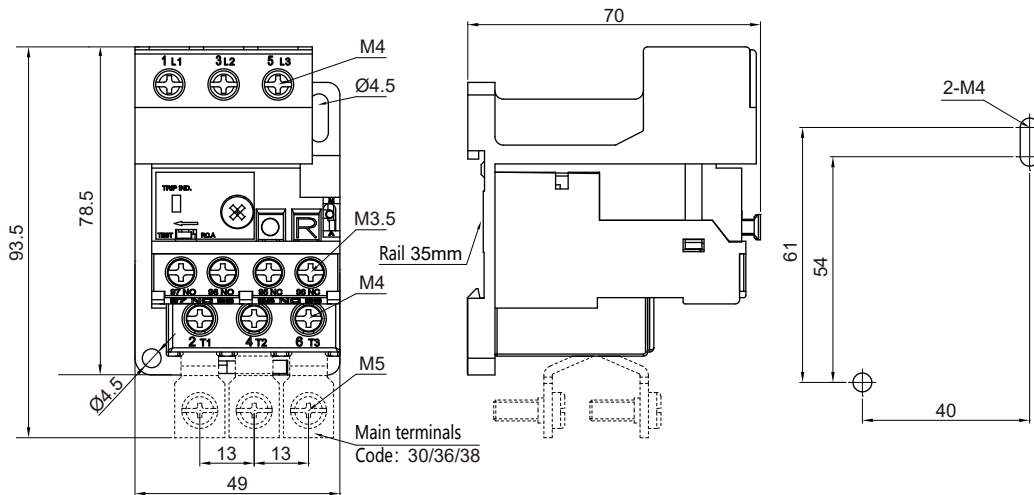

UER1-40/□□D

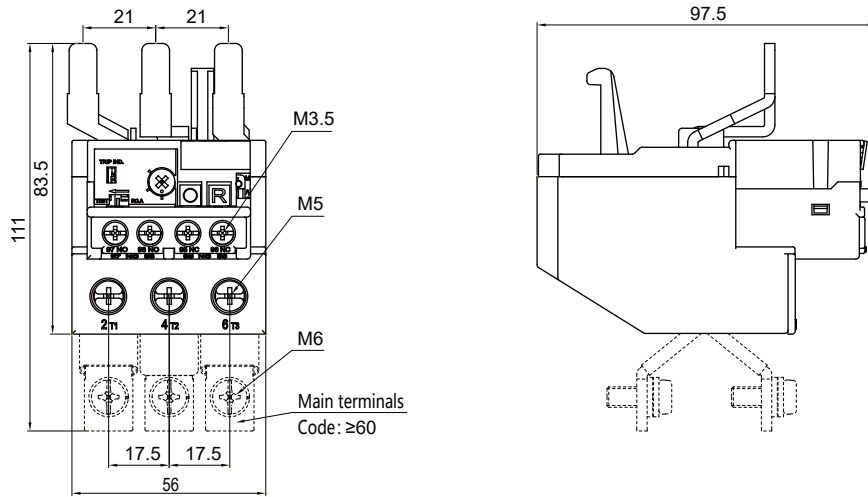

UER1-90/□□Z

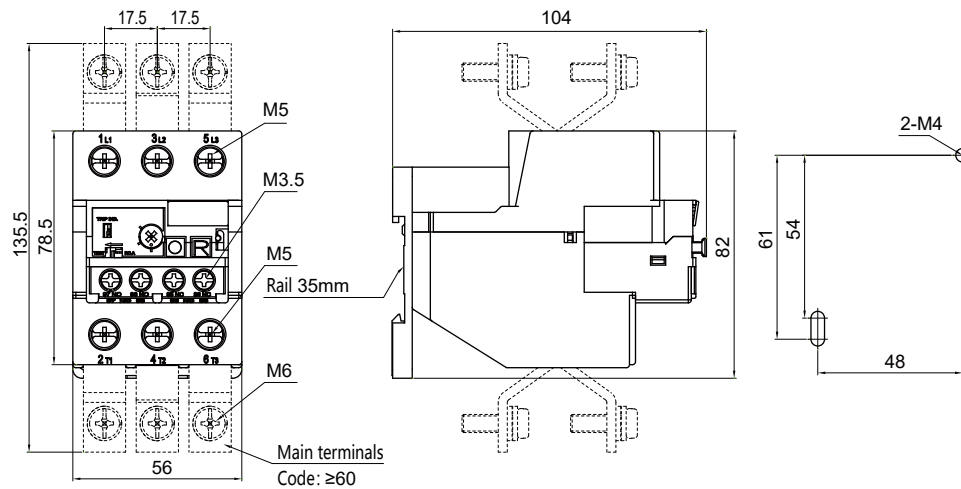

UER1-90/□□D

Note: The Unit is mm. The tolerance for mounting holes: ± 0.5 ; for other external dimensions: ± 2 , unless otherwise specified.

Dimensions

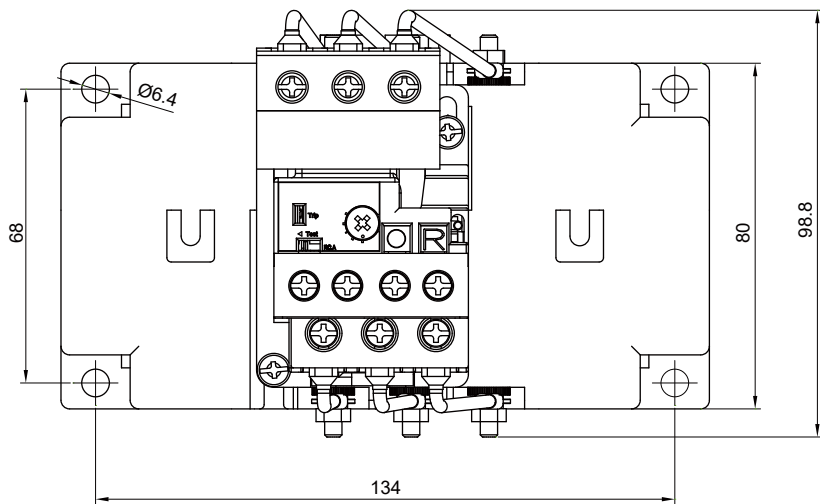
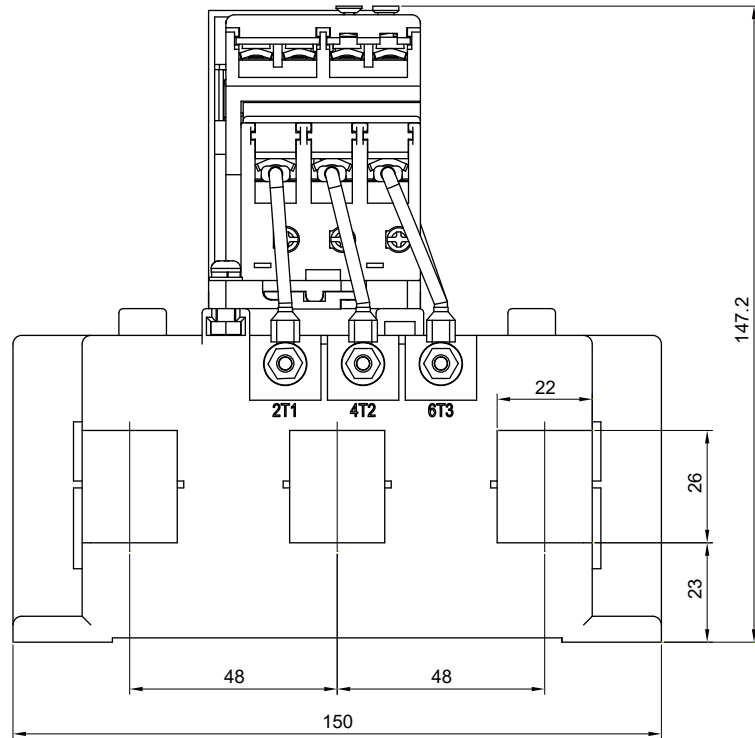

UER1-330/□□D

Note: The Unit is mm. The tolerance for mounting holes: ± 0.5 ; for other external dimensions: ± 2 , unless otherwise specified.

Circuit Diagram

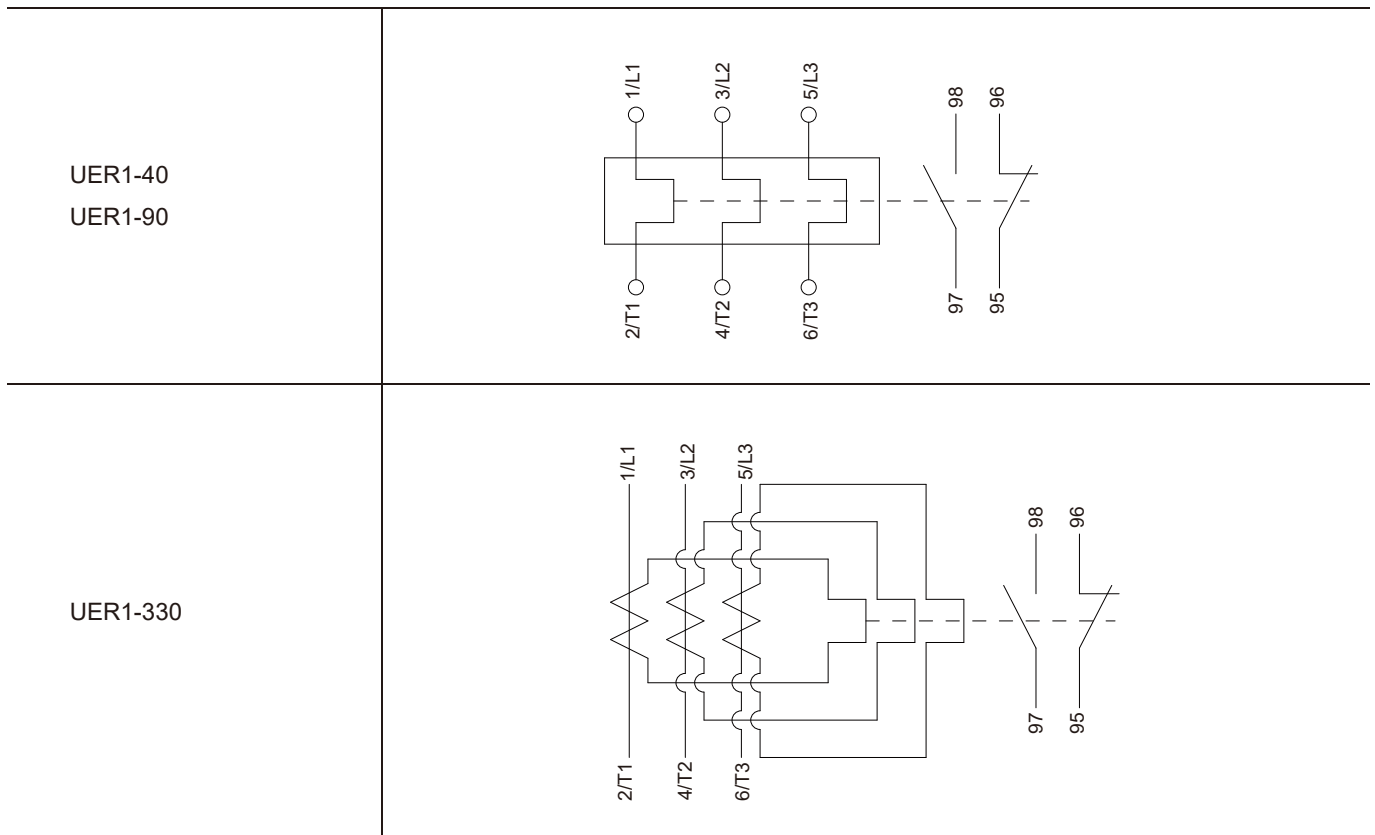

Tripping Curve

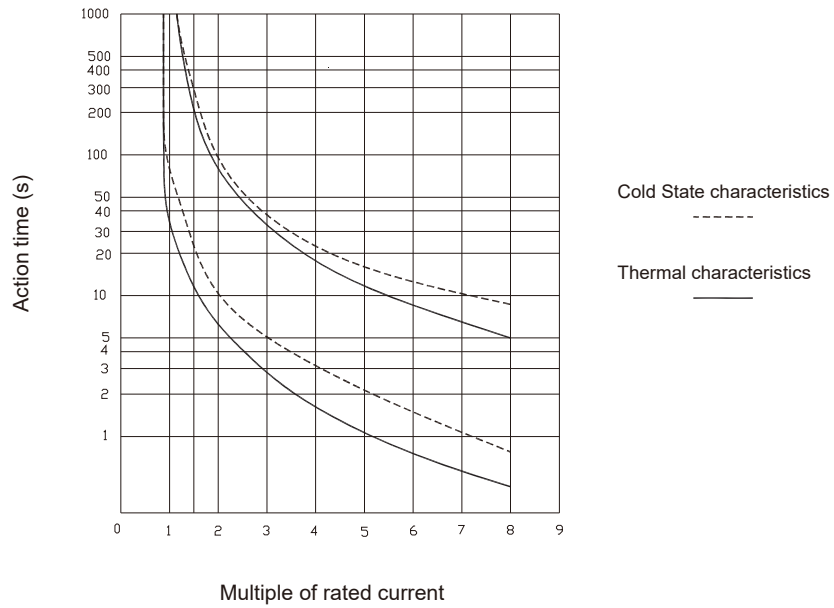

Action time characteristics of UER1-40 phase loss

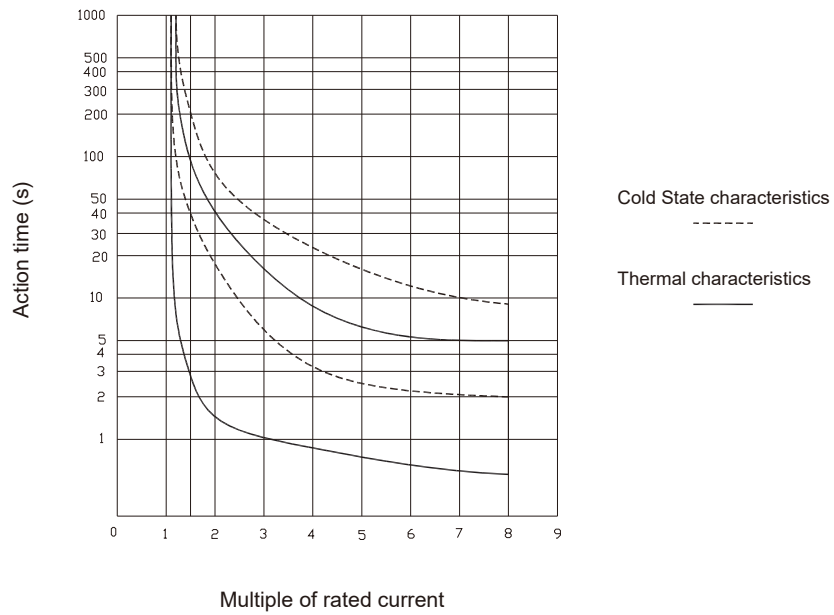

Action time characteristics of UER1-40 three phase overload

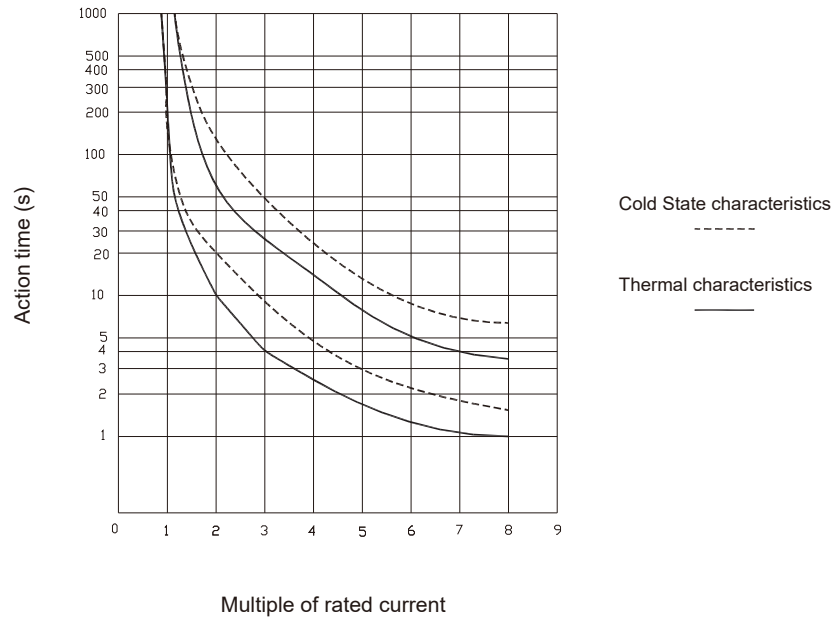

Action time characteristics of UER1-90 phase loss

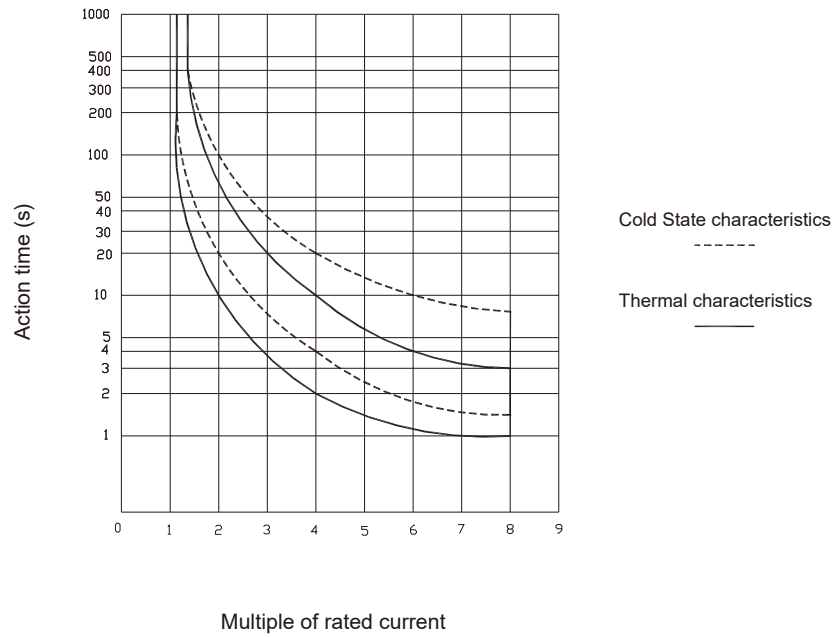

Action time characteristics of UER1-90 three phase overload

Reference Selection Table

Reference ⁽¹⁾		Current setting range	Coordinate with fuse		Coordinate with contactors (Combined mounting)	Net weight kg	
Combined mounting	Independent mounting		A	aM A		gG A	Combined mounting
UER1-40/0.16AZ	UER1-40/0.16AD	0.1...0.16	0.25	2	UEC1-09...38	0.114	0.170
UER1-40/0.25AZ	UER1-40/0.25AD	0.16...0.25	0.5	2		0.114	0.170
UER1-40/0.4AZ	UER1-40/0.4AD	0.25...0.4	1	2		0.114	0.170
UER1-40/0.5AZ	UER1-40/0.5AD	0.35...0.5	1	2		0.114	0.170
UER1-40/0.63AZ	UER1-40/0.63AD	0.45...0.63	1	2		0.114	0.170
UER1-40/0.8AZ	UER1-40/0.8AD	0.55...0.8	1	2		0.114	0.170
UER1-40/1.0AZ	UER1-40/1.0AD	0.75...1.0	2	4		0.114	0.170
UER1-40/1.3AZ	UER1-40/1.3AD	0.9...1.3	2	4		0.114	0.170
UER1-40/1.6AZ	UER1-40/1.6AD	1.1...1.6	2	4		0.114	0.170
UER1-40/2.0AZ	UER1-40/2.0AD	1.4...2.0	4	6		0.114	0.170
UER1-40/2.5AZ	UER1-40/2.5AD	1.8...2.5	4	6		0.114	0.170
UER1-40/3.2AZ	UER1-40/3.2AD	2.3...3.2	4	6		0.114	0.170
UER1-40/4.0AZ	UER1-40/4.0AD	2.9...4.0	6	10		0.114	0.170
UER1-40/4.8AZ	UER1-40/4.8AD	3.5...4.8	6	10		0.114	0.170
UER1-40/6.3AZ	UER1-40/6.3AD	4.5...6.3	8	16	0.114	0.170	
UER1-40/7.5AZ	UER1-40/7.5AD	5.5...7.5	12	20	0.114	0.170	
UER1-40/10AZ	UER1-40/10AD	7.2...10	12	20	0.114	0.170	
UER1-40/12.5AZ	UER1-40/12.5AD	9...12.5	16	25	UEC1-12...38	0.114	0.170
UER1-40/16AZ	UER1-40/16AD	11.3...16	20	35	UEC1-18...38	0.114	0.170
UER1-40/20AZ	UER1-40/20AD	15...20	25	50		0.114	0.170
UER1-40/21.5AZ	UER1-40/21.5AD	17.5...21.5	25	50	UEC1-25...38	0.114	0.170
UER1-40/25AZ	UER1-40/25AD	21...25	25	50		0.114	0.170
UER1-40/30AZ	UER1-40/30AD	24.5...30	40	63	UEC1-32...38	0.142	0.193
UER1-40/36AZ	UER1-40/36AD	29...36	40	63	UEC1-38	0.142	0.193
UER1-40/38AZ	UER1-40/38AD	33...38	40	100		0.142	0.193
UER1-90/25AZ	UER1-90/25AD	17...25	25	50	UEC1-40...95	0.323	0.376
UER1-90/36AZ	UER1-90/36AD	24.5...36	40	63		0.323	0.376
UER1-90/47AZ	UER1-90/47AD	35...47	63	100	UEC1-50...95	0.323	0.376
UER1-90/60AZ	UER1-90/60AD	45...60	63	100	UEC1-65...95	0.396	0.525
UER1-90/75AZ	UER1-90/75AD	58...75	80	125	UEC1-80...95	0.396	0.525
UER1-90/90AZ	UER1-90/90AD	72...90	100	160	UEC1-95	0.396	0.525
UER1-90/97AZ	UER1-90/97AD	77...97	100	160		0.396	0.525

Note:

⁽¹⁾ "A" (stand for three phase overload protection and phase lost protection) can be changed to "B" (stand for three phase overload protection) for UER1-40 and UER1-90 series reference in the table above. For detail information about reference, please refer to page 6.

Reference ⁽¹⁾		Current setting range	Coordinate with fuse		Coordinate with contactors (Combined mounting)	Net weight kg	
Combined mounting	Independent mounting		A	aM A		gG A	Combined mounting
—	UER1-330/120AD	87...120	160	200	—	—	1.39
—	UER1-330/144AD	105...144	160	200		—	1.39
—	UER1-330/200AD	145...200	200	250		—	1.39
—	UER1-330/240AD	175...240	250	315		—	1.39
—	UER1-330/280AD	203...280	315	315		—	1.39
—	UER1-330/336AD	245...336	400	400		—	1.39

Note:

⁽¹⁾ "A" (stand for three phase overload protection and phase lost protection) can be changed to "B" (stand for three phase overload protection) for UER1-40 and UER1-90 series reference in the table above. For detail information about reference, please refer to page 6.

Xiamen Hongfa Electroacoustic Co. Ltd

Add: No.560-578, Donglin Rd., Jimei North Ind. Dist., Xiamen, China

TEL: +86-592-6106688

FAX: +86-592-6106678

E-mail: marketing@hongfa.com

Marketing & Sales Network

Hongfa Europe GmbH

ADD: Marie-Curie-Ring 26, D-63477
Maintal, Germany

TEL: +49-6181-4306-0

E-mail: info@hongfa-europe.com

Hongfa America, Inc.

ADD: 20381 Hermana Circle, Lake
Forest, CA92630, USA

TEL: +1-714-669-2888

E-mail: sales@hongfaamerica.com

KG Technologies, Inc.

ADD: 6028 Stat Farm Drive
Rohnert Park, CA 94928, USA

TEL: +1.888.513.1874

E-mail: info@kgtechnologies.com

Hongfa Italy Srl

ADD: C/O Regus Business Center
Via Paracleso, 26 Agrate

B.za (MB), Italy

TEL: +39-0362-890-1544

E-mail: info@hongfa-europe.com

Hongfa Electroacoustic (Hongkong) Co., Ltd.

ADD: Rm 1810-12, 18/F., Shatin Galleria,
18-24 Shan Mei St., Fotan, N.T, HongKong

TEL: +852-2947-7889

E-mail: hongkong@hongfa.com

Shanghai Hongfa Electroacoustic Co., Ltd.

ADD: NO.51.341, Jiuxin Rd., Jiuting
Town, Songjiang Dist., Shanghai

TEL: +86-21-37693111

E-mail: shanghai@hongfa.com

Beijing Hongfa Electroacoustic Relay Co., Ltd.

ADD: 111Bldg, Phase IV Westside of Lian
-dong U Valley, Tongzhou Dist., Beijing

TEL: +86-10-56495556

E-mail: beijing@hongfa.com

Sichuan Hongfa Relay Co., Ltd.

ADD: 12F, Hongfa Building, No.6 Wuxing 4th
Road, Wuhou District, Chengdu

TEL: +86-28-86627550

E-mail: sichuan@hongfa.com

Hongfa India Branch

TEL: +91-9810415895

E-mail: amitkhuda@hongfa.com

TEL: +91-9971187792

E-mail: rohit@hongfa.com

Hongfa Korea Branch

ADD: RM302, Samwoo B/D, 286-4
Gaebong dong, Guro-gu,
Seoul, Korea

TEL: +82-10-5355-4899/+82-10-8704-4706

E-mail: korea@hongfa.com /
khlee@hongfa.com

Hongfa Brazil Branch

Non-automotive relay project

TEL: +86-0592-6196714

E-mail: southamerica@hongfa.com

Automotive relay project

TEL: +55-11-949697906

E-mail: mauro-loyola@hongfa.com

Hongfa Philippine Branch

TEL: +639177189352 / +639175780846

E-mail: nia-videna@hongfa.com

Hongfa Turkey Branch

TEL: +90-535-0221881

E-mail: info-turkey@hongfa.com

The relevant information on the products contained is for reference only.
For details, please consult our business staff.

Headquarter's Marketing & Sales Center
ADD: No.566-578, Donglin Rd., Jimei North Ind. Dist., Xiamen
E-mail: marketing@hongfa.com

SALES SERVICE HOTLINE
400-600-1502



HONGFA GROUP



HONGFA ELECTRIC